



**COCHIN PORT AUTHORITY
COCHIN-682009, KERALA, INDIA**

Tele: 91-0484-2666414, 2666871

Telefax: 91-0484-2666414

E-mail:coptce@gmail.com

**TENDER DOCUMENT FOR PROVIDING RCC CUM STEEL TUBULAR
FENDER PILES AT BAGGAGE JETTY, DIESEL PUMP JETTY, PILOT BOAT
JETTY & EMBARKATION JETTY'**

TECHNICAL BID (e-Tendering Mode)

Website:www.tenderwizard.com/CPT

CHIEF ENGINEER'S OFFICE

COCHIN PORT AUTHORITY

COCHIN-682009

TENDER No.T6/T-2006/2024-C

Rs.885/- (Rs.750 + 18% GST)

COCHIN PORT AUTHORITY

**TENDER FOR ‘PROVIDING RCC CUM STEEL TUBULAR FENDER PILES AT
BAGGAGE JETTY, DIESEL PUMP JETTY, PILOT BOAT JETTY &
EMBARKATION JETTY’.
(Tender No.T6/T-2006/2024-C)**

CONTENTS

Sl No:	Items	Page Nos.
1	Tender Notice	2-10
2	Tender for Works	11-12
3	Contract Data	13-16
4	Instructions to Tenderers	17-21
5	General Description and Special Conditions of Contract	22-29
6	Detailed specifications for materials to be used on works	30-32
7	Detailed Specifications for items of Works	33-42
8	Annexure-I	43
9	Annexure-II	44
10	Annexure-III	45
11	Drawing	46
12	General Conditions of Contract-2016. (Attached Separately)	

SIGNATURE OF TENDERER

COCHIN PORT AUTHORITY



Chief Engineer's Office
Cochin Port Authority
W/Island , Cochin – 682009, KERALA
Tele: 91-0484-2666414/0484-258-2400
website: www.cochinport.gov.in

Tender No. T6/T-2006/2024-C

Date : 11/03/2024

NOTICE INVITING TENDER

Electronic Tenders (**e-tenders**) on percentage basis are invited by Cochin Port Authority on behalf of GoI from reputed contractors in Single Stage Two Cover bidding procedure [Technical Bid and Financial Bid], meeting the Minimum Eligibility Criteria specified below for the work of “**Providing RCC cum Steel Tubular Fender piles at Baggage jetty, Diesel pump jetty, Pilot boat jetty & Embarkation jetty**”.

1. **Minimum Eligibility Criteria:**

a) **Experience**

The tenderers should have experience of having successfully completed during the last 7 (seven) years ending **29th February, 2024**, at least either:

i) Three Similar Works each costing not less than **Rs. 7.43 lakhs**

(OR)

ii) Two Similar Works each costing not less than **Rs.9.28 lakhs**

(OR)

iii) One Similar Work costing not less than **Rs.14.85 lakhs**

b) **Financial Turnover**

Average Financial Turnover of the tenderer over the last three financial years ending 31st March 2023 [2020-'21, 2021-'22 & 2022-'23] shall not be less than **Rs.5.57 lakhs**.

Explanatory Notes to a) & b) :

i. Similar work(s) means “**Civil Construction work/ Civil Marine Works/ Civil Repair Works/ Providing Fender piles**”. The experience certificate of works executed in private sectors/ organisations shall be considered for qualification, only on submission of TDS certificate (Form 26AS) along with work order and completion certificate.

- ii. Copy of completion certificates of each work issued by the employer/owner/ responsible officer of the employer/owner under whom he has executed such contract shall be attached. The certificate shall contain details of work involved specifying the nature of work, the completion cost of the work, date of commencement & date of completion of the work.
- iii. The works reckoned for the above purpose are those executed by the tenderers as prime Contractor or proportionately as member of joint venture or Sub Contractor. The Sub-Contractor shall be an authorized and approved Sub-Contractor by the Employer of the work(s) against which the tenderer has claimed his experience. The tenderer shall attach attested copy(s) of approval issued by the Employer(s) authorizing as a Sub-Contractor; in proof of the claim of the tenderer as a sub-Contractor. The tenderer is also obliged to produce the original of the certified copy(s) on request by the department.
- iv. Following enhancement factors will be used for the costs of works executed for bringing the financial figures to a common base value in respect of the works completed in the past years.

Table 1

Year before	Multiplying factor
One year	1.07
Two years	1.14
Three years	1.21
Four years	1.28
Five years	1.35
Six years	1.42

- v. **Financial Turnover:**
In proof of Financial Turnover Audited Annual Accounts Statements (Balance Sheet & Profit & Loss Account Statement) & Turnover Certificate signed by the Chartered Accountant or IT returns duly acknowledged by the Income Tax department along with Computation Statement signed by the Chartered Accountant, for the last three years ending on.....shall be produced by the tenderer.

2. Other Eligibility Considerations

2.1 Even though the bidders meet the above qualifying criteria, they are subject to be disqualified if they have:

- i) made misleading or false representations in the forms, statements and attachments submitted in proof of the qualification requirements; and/or
- ii) record of poor performance such as abandoning the works, not properly completing the contract, inordinate delays in completion, litigation history, or financial failures, disqualifications/ black listing/ debarring by Govt. departments etc.

2.2 The bidders having EPF/ ESI registration certificates only shall be considered for qualification in the tender, if applicable, as per EPF /ESI Acts. In case, the Tenderer does not have the required number of employees which makes such registration mandatory, an Undertaking as per Annexure I to the effect shall be furnished.

3. Pertinent information to the tender is given in the following Tables:

i) Schedule of different activities till submission of the bid are detailed as under:

Table 2

Sl. No.	Particulars	Date and Time
1	Tender e- publication date	<i>11-03-2024</i>
2	Download period of Bid Documents	<i>11 -03-2024 to 01-04-2024</i>
3	Date of Pre-Bid meeting	<i>Not Applicable</i>
4	Last date for seeking clarification	<i>25 -03-2024</i>
5	Last date and time of submission of Bid	<i>01-04-2024 up to 14.30 hrs</i>
6	Date and time of opening the Bid	<i>01-04-2024 after 15.00 hrs</i>

ii) Bid information :

Table 3

i)	Estimated Amount put to Tender	Rs.18,56,600/-
ii)	Earnest Money Deposit	Rs.37,140/- furnished through Demand Draft or Banker's Cheque drawn in favour of Financial Adviser & Chief Accounts Officer, CoPA from any Nationalised Bank/ Scheduled Bank in India or through RTGS/NEFT mode.
iii)	Cost of Bid document	Rs.885/- (Rs.750/-+18% GST) (Non refundable) furnished either through Demand Draft/ Banker's Cheque drawn in favour of the Financial Adviser & Chief Accounts Officer, CoPA from any Nationalized Bank/ Scheduled Bank in India, or through RTGS/NEFT mode. being the cost of single copy of the tender document
iv)	Validity period of Tender	120 days from the Last Date of Submission of Bid.
v)	Time for Completion	4 Months from the date of commencement

4. This work essentially comprises of the following:

- i. Pulling out broken stumps of fender pile
 - ii. Fabricating, supplying, transporting, pitching & driving 300mm dia. Steel Tubular fender piles.
 - iii. Providing Reinforced cement concrete M30 grade with 20mm metal for precast piles.
 - iv. Filling inside the tubular fender piles with Crusher Run Screening.
 - v. Providing M15 grade Cement concrete for plugging the pile.
 - vi. Painting the outer surface of the Tubular fender pile.
5. Tender documents can be downloaded from the e-Tendering portal www.tenderwizard.com/CPT on the dates specified in Table 2 given above by making online requisition. Bid document will also be available in Cochin Port website (www.cochinport.gov.in) as well as Govt. tender website, www.eprocure.gov.in, which can be downloaded for submission. The cost of bid document and EMD shall be furnished in the form of Demand Draft/ Banker's Cheque drawn in favour of FA & CAO, CoPA or through RTGS/NEFT mode. The bidder shall submit the Originals of (i) DD / Bankers Cheque towards the cost of tender document and EMD and (ii) Power of Attorney in favour of signatory(s) to the tender if applicable, with letter of submission in a sealed cover to the **Dy. Chief Engineer, Cochin Port Authority, W/Island, Cochin-682009, Kerala**, within 3 (Three) working days from the date of opening of the bid. **Non submission of original financial document towards cost of tender document and EMD within 3 (Three) working days from the date of opening of the bid, will make the tender liable for rejection, and such tenders would not be evaluated further.**
6. The bidders need to obtain the one time User ID & password for log-in to in e-**Tendering** system from the service provider **KEONICS** by paying registration amount of **Rs.1124/-** by online Payment using Credit/Debit Card/Net banking or DD in favour of "KSEDCL, Bangalore".
7. The intending bidder must have valid Class-II or III digital signature certificate to submit the bid. For further details and to obtain the digital signature, please contact e-Tender Help Desk No.080-40482000 / 9746118529 / 9605557738.
8. Tenders shall be submitted "**online**" strictly in accordance with the Instructions to Tenderers and Terms & Conditions given in the tender document.
9. The bidder is responsible to download Addenda/ Amendments/ Errata/ Replies to the queries of the bidders etc., if any, issued by the Employer, from the website before submission of the bid. **Any shortfall in uploading the said Addenda/ Amendments/ Errata/ Replies to the queries of Tenderer etc. duly signed along with the downloaded documents while uploading the Tender will render the Tender incomplete and such incomplete Tender Documents may be rejected by the employer and would not be evaluated.**
10. All Bids are to be submitted **online only** on the website www.tenderwizard.com/COPT. No Bids shall be accepted off-line (Hard copy).

11. **EARNEST MONEY TO BE DEPOSITED**

11.1 Each tender should be accompanied by an Earnest Money amounting to **Rs.37,140/-**.

11.2 The Earnest Money can be deposited through Demand Draft or Banker's Cheque from a Scheduled Bank in India, drawn in favour of Financial Adviser & Chief Accounts Officer, COCHIN PORT AUTHORITY or online payment through RTGS/NEFT. The original DD/ Banker's Cheque shall be submitted to the Dy.CE, Cochin Port Authority, Cochin-09, **within 3 (THREE) working days from the date of opening of the bid**. Scanned copy of the DD/ Banker's Cheque shall be attached with the tender submitted "online". If online payment is made, the evidence thereof shall be attached with the tender submitted "online". If hard copy of the original DD/Bankers Cheque is not received within the stipulated period, or if the evidence of making online payment towards EMD is not attached with the tender submitted online, then such bids will not be further evaluated and shall be rejected summarily. The Earnest Money deposited will not carry any interest.

11.3 Bank details of Cochin Port Authority are given below.

Name of bank	:	State Bank of India
Name of Branch	:	Cochin Port Trust Branch
IFSC Code	:	SBIN0006367
Account No	:	41401802288
Account Holders Name	:	Cochin Port Authority

11.4 EMD of L1 & L2 bidder shall be refunded to the respective bidders on submission and acceptance of Performance Security and entering into agreement by the L1 Bidder. EMD of other bidders will be refunded immediately after finalization of the bid.

12. Cochin Port Authority will not be held responsible for any technical snag or net work failure during online bidding. It is the bidder's responsibility to comply with the system requirements i.e. hardware, software and internet connectivity at bidder's premises, to access the e-Tender portal. Under any circumstances, Cochin Port Authority shall not be liable to the bidders for any direct/indirect loss or damages incurred by them arising out of incorrect use of the e-Tender system or internet connectivity.

13. **Securities:**

13.1 Security Deposit (SD) shall be 10% of the Contract value or value of the work done whichever is higher and it shall consist of the following:

- a) **Performance Security** 5% of contract value payable on award of the work.
- B) **Retention Money:** @ 5% of the gross amount of each bill.

The total amount thus deposited towards SD will be retained as security for the due and proper fulfillment of the Contract and will not carry any interest. Such deposit shall be forfeited on failure to perform or non-fulfillment by the Contractor of the terms and conditions of the Contract.

13.2 **Performance Security:** The Performance Security retained till end of Defect Liability period (1 year from the date of completion of work) shall be 5% of

- Contract Value or Cost of Work Done, whichever is higher. So, initially 5% of the Contract value shall be furnished as Performance Security.
- 13.3 The Security Deposit/ Performance Security @ 5% of the value of the contract awarded (Rounded off to the nearest Rs.1000/-), shall be furnished by the Contractor to the Employer, not later than **14 days** from the date of receipt of letter of acceptance or such extension of that period as may be permitted by the official of Cochin Port writing, and shall be furnished in one of the following forms:
- i) Banker's Cheque / Demand Draft of a Scheduled Bank/ online payment through RTGS/NEFT. If online payment is made, the evidence thereof shall be submitted to the office.
 - ii) An irrevocable Bank Guarantee(BG) enforceable and encashable at Cochin, drawn from any Scheduled Bank operating in India as per the prescribed proforma.
- 13.4 **The BG furnished towards the Performance Security shall be valid until a date 30 days from the day of expiry of the Defect Liability Period stipulated as per the terms of the Contract.**
- 13.5 If Performance Security is not furnished within the period as specified above or such extension of that period as may be permitted by the official of Cochin Port Authority in writing, Cochin Port Authority at its discretion may cancel the Letter of Acceptance without paying any compensation to such bidder, and in addition to forfeiture of EMD. In addition, such bidder shall not be eligible to participate in the tenders invited by COCHIN PORT AUTHORITY for a period of **Two Years from the date of such cancellation of Letter of Acceptance.**
- 13.6 **Retention Money:** Retention Money @ 5% shall be retained from each payment due to the Contractor.
- 13.7 Retention Money shall be deducted at 5% of the gross amount of the bill from the first Running Account bill onwards till the recovered sum alongwith Performance Security amounts to 10% of the Contract value or the value of the work done whichever is higher at all times. **Retention Money shall be refunded to the Contractor within 14 days from the date of payment of final bill.**
- 13.8 If the Cost of Work done exceeds the Contract Value, the total amount retained as Security Deposit considering the Performance Security initially submitted together with the Retention Money recovered from the running account bills, shall amount to 10% of the Cost of Work done.
- 13.9 In cases where cost of Work done exceeds the Contract Value while releasing the Retention Money after payment of Final Bill, only 5% cost of Work Done is released, instead of the entire Retention Money recovered from the bills. The balance amount shall be retained; to make up for the shortage in the Performance Security, upto the completion of Defects Liability Period.
- 14 In the event of the tenderer, after the issue of the communication of acceptance of offer by Cochin Port Authority, failing /refusing to execute the agreement as hereinafter provided, the tenderer shall be deemed to have abandoned the Contract and such an act shall amount to and be construed as the Contractor's calculated

and willful breach of the Contract, the cost and consequence of which shall be to the sole account of the tenderer and upon such an event, Cochin Port Authority shall have full right to claim damages therefore either together with or in addition to the forfeiture of Earnest Money Deposit.

15 **Signing of Agreement:**

15.1 The successful tenderer will be required to execute within **21 days** from the date of receipt of Letter of Acceptance and after submission of Performance Security, an agreement at his expense on proper value Kerala State Stamp Paper in the prescribed departmental form, consisting of:

- a) The Tender Notice, all the documents including additional conditions/specifications and drawings, if any, forming the tender as issued at the time of invitation of tender and acceptance thereof together with any correspondence leading there to, and
- b) General Conditions of Contract-2016 (GCC), for the due and proper fulfillment of the Contract.

If Agreement is not executed within the period as specified above or such extension of that period as may be permitted by the official of Cochin Port Authority in writing, Cochin Port Authority at its discretion may cancel the Letter of Acceptance without paying any compensation to such bidder, and in addition to forfeiture of Performance Security.

15.2 The Contractor shall make 10 copies of the Agreement and submit to CoPA within 7 days following the date of signing of Agreement.

16 Till signing of agreement the tender together with the acceptance letter shall constitute a binding Contract between the Contractor and Cochin Port.

17 Failure to comply with conditions **3ii(iv), 13 and 15** above will entail forfeiture of the Earnest Money.

18. **MSME Bidders who are registered with District Industries Centre (DIC) or Khadi and Village Industries Commission (KVIC) or Khadi and Village Industries Board (KVIB) or Coir Board or National Small Industries Corporation (NSIC) or directorate of Handicrafts and Handlooms or Udyog Aadhaar Memorandum or any other body specified by Ministry of MSME for similar nature of Works shall be eligible for issue of Bid Document free of cost and exemption from payment for issue of tender document & payment of EMD. They are required to submit documentary proof of such registration along with the offer, as detailed in Instructions to Bidders, for claiming the available exemptions and a scanned copy of Exemption Certificate duly notarized shall be uploaded in the e-Tender Portal. If the Registration Certificate does not pertain to the Category of 'Similar Works' mentioned above, the Tender will be rejected. Further, for claiming such exemption for EMD, they would have to submit an undertaking as specified in Annexure-III in lieu of EMD.**

19. The undersigned reserves the right to reject/cancel/postpone any one or all tenders at any stage of the tender, which shall be binding on all bidders. It is not

- mandatory for Cochin Port to accept the bid of the Lowest Bidder, and Cochin Port at its discretion may accept the bid of any bidder, without mentioning any reason.
- 19 CoPA will determine whether the Tender is substantially responsive to the requirements of the Tender documents. For the purpose of this clause a substantially responsive Tender is one which inter alia conforms to all the terms, general conditions and specifications of the Tender documents and technically suitable. The Tenderer shall carefully submit all the documents as required under the Tender failing which the offer is liable to be treated as non-responsive. A Tender which, in relation to the cost estimates of CoPA, is seriously unbalanced may be rejected as non-responsive. The Tender which does not satisfy the pre-qualification criteria shall summarily be rejected and shall not be considered for further evaluation Tenders which do not fulfill all or any of the above conditions or which contain any other condition of any sort including conditional rebates or are incomplete in any respect is liable for rejection. Such tenders shall be entered in the tender opening register but their rates shall neither be read out nor entered in the register. Only remark mentioning the reason of rejection in brief shall be appended against such entry.
- 20 The Tenderer shall quote realistic rates in respect of the services to be provided. The rates shall be firm and no other increase or decrease in prices will be allowed during the currency of the contract. Canvassing in connection with tender is strictly prohibited and tenders submitted by the Contractors who resort to canvassing will be liable to rejection.
- 21 **Taxes and Duties:**
- 21.1 Deductions towards statutory taxes as per the rules, prevailing in force at the time of payment of bills shall be made while releasing the bill amount.
- 21.2 GST for the work will be paid extra by the Port. The GST applicable as per law can be billed on the Port Authority, which will be paid to the Contractor by the Board along with the bills, for which the Contractor holds valid GST Registration number and the GST is being collected. The following are also to be considered while claiming payment towards GST:
- i. Invoice in specific format should be provided by the Contractor for every payment.
 - ii. GST Registration Number of Cochin Port Authority and the Contractor is to be clearly mentioned with all the bills.
 - iii. Invoice should be attached along with the running bills.
 - iv. The Contractor shall comply all the GST regulations, viz.; timely uploading of invoices and issue of debit/ credit notes.
- 22 Any stipulation by a tenderer that taxes and duties deductible from these bills should be borne by the Port Authority will result in the summary rejection of his /their tender.
- 23 Cess as per Building and other Construction Workers Welfare Cess Act (Act 28 of 1996) at the rate of one percent or at the rates prevailing in force at the time of

payment of bills, of the cost of construction should be borne by the Contractor and the same will be deducted from Contractor's bills while making payment or when crediting amount to Contractor's account.

24 The Tender Document shall form part of the Contract.

S/d-

Dy. Chief Engineer-I

COCHIN PORT AUTHORITY

FOR AND ON BEHALF OF THE BOARD OF MAJOR PORT

AUTHORITY FOR COCHIN PORT

2. TENDER FOR WORKS

To

**The Board of
Major Port Authority
for Cochin Port
Through
The Chief Engineer
Cochin Port Authority, Cochin-9**

I/We hereby tender for the execution of the work specified in the underwritten memorandum within the time specified in such memorandum at the rates specified in the schedule attached hereto and in accordance in all respects with the specifications, designs, drawings and instructions in writing referred to in 'clause 16' of the General Conditions of Contract and with such materials as are provided for, by and in all other respects in accordance with such conditions so far as applicable.

MEMORANDUM

- a) General description of work : **Providing RCC cum Steel Tubular Fender piles at Baggage jetty, Diesel pump jetty, Pilot boat jetty & Embarkation jetty.**
- b) Estimated cost : **Rs.18,56,560/-**
- c) Earnest Money : **Rs.37,140/- (2%)**
- d) Security Deposit : 10% of the value of the Contract awarded or value of the work done whichever is higher. (Performance Security @ 5% of contract value payable on award of the work and Retention Money 5% of the gross amount of each bill)
- e) Percentage, if any, to be deducted from the bills : The Retention Money will be recovered from the first running bill onwards at the rate of 5% of the gross amount of each bill.
- f) Time allowed for commencement of work from the date of receipt of Letter of Acceptance/work order : **7 days**
- g) Time allowed for the work from the date of commencement of work : **4 Months**
- h) Schedule, specifications, conditions, drawings etc. : As per "Contents" sheet attached.

Should this tender be accepted, I/We hereby agree to abide by and fulfill all the terms and provisions of the tender and conditions of Contract annexed hereto and in default to execute an agreement with CoPA in the prescribed form within prescribed period, or submission of Performance Security within the prescribed period, agree to forfeit the Earnest Money deposited by me/us, in addition to any other remedy available with Cochin Port against me/us. The sum of Rs..... which will be deposited with Financial Adviser and Chief Accounts Officer of the Port Authority as Performance Security (a) the full value of which is to be absolutely forfeited to CoPA without prejudice to any other rights or remedies of CoPA should I/We fail to commence the work specified in the Contract Data or should I/We make any delay in progress of the work or if the contract is terminated on my/our default. ; or (b) the full value of which shall be retained by the Board on account of the security deposit to execute all the works referred to in the tender documents upon the terms and conditions contained or referred to therein and to carry out such deviations as may be ordered, upto maximum of the percentage mentioned in Contract Data and those in excess of that limit at the rates to be determined in accordance with the provision contained in Clause 40.3 of the General Conditions of Contract.

Dated the day of 2024

Signature of the Tenderer

Address :

Witness :

Address :

Occupation :

ACCEPTANCE

The above tender is hereby accepted by me for and on behalf of the Board.

Dated theday of2024.

Dated.....

Chief Engineer

COCHIN PORT AUTHORITY

3. CONTRACT DATA

Items marked “N/A” do not apply in this Contract.

Sl. No.	Description	Reference Clause No. in GCC																
1	<i>The following documents are also part of the Contract</i>																	
	The Schedule of other Contractors	(8.2)																
	The Schedule of Key personnel – As per Tender	(9)																
	<table border="1" style="width: 100%; border-collapse: collapse;"> <thead> <tr> <th style="text-align: center;">Qualification of Staff</th> <th style="text-align: center;">No.</th> <th style="text-align: center;">Min. Experience (Years)</th> <th style="text-align: center;">Rate of recovery in case of non-compliance</th> </tr> </thead> <tbody> <tr> <td style="text-align: center;">Graduate Engineer</td> <td style="text-align: center;">1</td> <td style="text-align: center;">2</td> <td style="text-align: center;">Rs.15,000/- p.m</td> </tr> <tr> <td style="text-align: center;">or</td> <td></td> <td></td> <td></td> </tr> <tr> <td style="text-align: center;">Diploma Engineer</td> <td style="text-align: center;">1</td> <td style="text-align: center;">5</td> <td style="text-align: center;">Rs.15,000/- p.m</td> </tr> </tbody> </table>	Qualification of Staff	No.	Min. Experience (Years)	Rate of recovery in case of non-compliance	Graduate Engineer	1	2	Rs.15,000/- p.m	or				Diploma Engineer	1	5	Rs.15,000/- p.m	
Qualification of Staff	No.	Min. Experience (Years)	Rate of recovery in case of non-compliance															
Graduate Engineer	1	2	Rs.15,000/- p.m															
or																		
Diploma Engineer	1	5	Rs.15,000/- p.m															
2	The Employer is:	(1)																
	The Board of Major Port Authority for Cochin Port, COCHIN PORT AUTHORITY, Cochin -9.																	
	Name of Authorized Representative:																	
	Name : Sri. B.Kasiviswanathan, IRSME, Chairperson, Cochin Port Authority, Cochin -9.																	
3	The Engineer is																	
	Name : Sri. Sathyan.A.G, Chief Engineer i/c, Cochin Port Authority, Cochin-09.																	
	Name of Nominee/Engineer-in-Charge: Name: Sri. Sathyan.A.G, Dy. Chief Engineer-I																	
4	Name of Contract- Providing RCC cum Steel Tubular Fender piles at Baggage jetty, Diesel pump jetty, Pilot boat jetty & Embarkation jetty. Tender No. T6/T-2006/2024-C	(1)																

Sl. No.	Description	Reference Clause No. in GCC	
5	10 copies of Contract Agreement shall be furnished by the Contractor	(7.1)	
6	Tender document and other data are available at Cochin Port web site, Government of India CPP Portal and e – tendering portal. www.cochinport.gov.in www.eprocure.gov.in www.tenderwizard.com/CPT	(7.2)	
7	The Intended completion date for the whole of the Work is 30 days with the following milestones:	(17,28)	
8	Milestone dates:		
	Physical works to be completed		Period from the date of receipt of LoA to commence and proceed with the work
	4 Months		7 days
9	The following shall form part of the Contract Document: (1) Agreement (2) Letter of Acceptance (3) Bill of quantities (4) Contractor’s Bid (5) Correspondence exchanged after the opening of the Bid and before the issue of Letter of Acceptance by which the Condition of Contract are amended, varied or modified in any way by mutual consent (to be enumerated). (6) Contract Data (7) General Conditions of Contract (8) General Description and Special Conditions of Contract (9) Technical Specifications (10) Drawings if any and (11) Any other documents listed in the Contract Data as forming part of the Contract.	(2.3)	
10	The Contractor shall submit a Program for the Works within 3 days of date of the Letter of Acceptance.	(27)	

Sl. No.	Description	Reference Clause No. in GCC
11	The site possession date The site will be handed over within 7 days after issue of LoA, and failure to take over the same within such period shall be attributable to contractor alone.	(21)
12	The start date shall be 3 days from the date of receipt of the Letter of Acceptance (LoA) by the Contractor.	(1)
13	The site is located in W/Island.	
14	The Defects Liability Period: One year from the date of completion of the work.	(36)
15	The minimum insurance cover for physical property, injury and death is Rs.10 lakhs (Rupees Ten lakhs) per occurrence with the number of occurrences unlimited. After each occurrence, Contractor will pay additional premium necessary to make insurance valid always.	(13)
16	The following events shall also be Compensation Events: NIL	(44)
17	The period between Programme updates shall be 7 days.	(27)
18	The amount to be withheld for late submission of an updated programme shall be ----- NA	(27)
19	The language of the Contract documents is English.	(3)
20	The law, which applies to the Contract, is the law of Union of India.	(3)
21	The currency of the Contract is Indian Rupees.	(46)
22	The proportion of payments retained (Retention Money) shall be 5% from each bill subject to a maximum of 5% of the contract price. - NA	(48)
23	The maximum amount of Liquidated Damages for the whole of the works is 10% of the Contract Price.	(49)
24	The amounts of the advance payments :	(51)
	The advance payments as applicable to the contract are: NA	
25	Repayment of advance payment for mobilization: NA	(51)
26	Repayment of advance payment for Construction and equipment: NA	(51)
27	Repayment of Secured Advance: NA	(51)

Sl. No.	Description	Reference Clause No. in GCC
28	The date by which “as-built” drawings are required is within 90 days of issue of certificate of completion of whole or section of the work, as the case may be: NA	(58)
29	The amount to be withheld for failing to supply “as built” drawings and/or operating and maintenance manuals by the date required is ----- NA	(58)
30	Schedule of Rates Applicable: CPWD DSR 2018 + 55% Cost Index x 0.8768 for deducting GST.	
31	Base Rate for materials to be considered for price variation NA	(47)
32	Permissible wastage on theoretical quantities of (a) Cement : (+) 2% (b) Steel Reinforcement and structural steel sections for each diameter, section and category : (+) 5.99 % (c) Bitumen/Bitumen emulsion : (+) 2.5%	(47)

4.INSTRUCTIONS TO TENDERERS

- 4.1 Electronic Tenders (e-tenders) on percentage basis under “Two Cover system” are invited for **“Providing RCC cum Steel Tubular Fender piles at Baggage jetty, Diesel pump jetty, Pilot boat jetty & Embarkation jetty”**.
- 4.2 The tenderer shall submit the tender Cover-A (Hard Copy of EMD & Cost of Tender form) **within 3 (THREE) working days from the date of opening of the bid.** All the Technical Bid documents & Price Bid shall be submitted **“online”**.
- 4.3 The Tender Document will be available as three separate files in the e-tendering Portal:
- i. A. Technical Bid Documents (as per Sl. No 1 to 7 of the Contents sheet)
 - ii. B. Price Bid: Schedule of quantities of Work- Schedule-A and
 - iii. C. General Conditions of Contract-2016
- 4.4 The tenderer shall upload the documents indicated in 4.3 (i) & (iii) above and also the Schedule of Quantities(Percentage) [as per Cl.4.3(ii), duly filled in, **“online”**.

4.5 SUBMISSION OF TENDERS

- 4.5.1 The Cover A containing hard copy of EMD & Cost of Tender form as mentioned in Table 3 of Tender Notice shall be submitted **within 3 (THREE) working days from the date of opening of the bid.**

4.5.2 Technical Bid (Online mode)

Technical Bid shall contain all technical and commercial details except Schedule of Quantities. It shall consist scanned/ soft copies of the following documents.

- a) A covering letter from the tenderer enlisting the enclosures/ attachments.
 - b) Original Tender Document (Technical Bid) except Schedule of Quantities.
 - c) Copy of the documents in proof of fulfillment of the Minimum Qualification Criteria.
 - d) Copy of PAN Card, ESI/EPF & GST Registration documents.
 - e) Copy of Authorisation documents of Signatory of the bid in case of Registered Partnership firm / Limited company
 - f) Partnership deed or Memorandum and Article of Association of the company and registration certificate of the company as the case may be.
 - g) Any other relevant document.
- 4.5.2.3 Scanned copies of all documents as per Clause 4.5.2, EMD and Cost of Tender Form shall be submitted as “Technical Bid”.
- 4.5.2.4 Departmental Tender Document (except Schedule of Quantities), along with scanned copies of Cost of Tender form, EMD and other documents as per Clause 4.5.2 shall be submitted **‘online’** before 14.30 hrs of opening date of the Tender. **In no case shall filled in Price Bid - Schedule of Quantities be submitted in hard copy, as it shall result in rejection of the tender.**
- 4.5.2.5 No changes shall be made in the tender documents. An undertaking that no changes have been made in the Tender document downloaded has to be furnished in Annexure-II

4.5.3 Price Bid:

4.5.3.1 Price Bid shall contain only the “Schedule of Quantities”, which shall be submitted only in e-tendering mode.

4.5.3.2 Tenderer should ensure that his tendered percentage as per ‘Price Bid’ is not mentioned anywhere in any other documents, directly or indirectly. If any such mention is made, the tender will become invalid and shall become liable for rejection.

4.6 **Minimum Eligibility Criteria:** The bidders eligible for participating in the tender may be Individual, Proprietorship, Registered Partnership firms, L.L.P, Company or JV. The proof thereof shall be submitted.

a) Experience

The tenderers should have experience of having successfully completed during the last 7 (seven) years ending **29th February, 2024**, at least either:

- i) Three Similar Works each costing not less than **Rs.7.43 lakhs**
(OR)
- ii) Two Similar Works each costing not less than **Rs.9.28 lakhs**
(OR)
- iii) One Similar Work costing not less than **Rs.14.85 lakhs**

b) Financial Turnover

Average Financial Turnover of the tenderer over the last three financial years ending 31st March 2023 [2020-‘21, 2021-‘22& 2022-‘23] shall not be less than **Rs.5.57 lakhs**.

Explanatory Notes to a) & b) :

- i. Similar work(s) means “***Civil Construction work/ Civil Marine Works/ Civil Repair Works/ Providing Fender piles***”. The experience certificate of works executed in private sectors/ organisations shall be considered for qualification, only on submission of TDS certificate along with work order and completion certificate.
- ii. Copy of completion certificates of each work issued by the employer/ owner/ responsible officer of the employer/owner under whom he has executed such contract shall be attached. The certificate shall contain details of work involved specifying the nature of work, the completion cost of the work, date of commencement & date of completion of the work.
- iii. The works reckoned for the above purpose are those executed by the tenderers as prime Contractor or proportionately as member of joint venture or Sub Contractor. The Sub-Contractor shall be an authorized and approved Sub-Contractor by the Employer of the work(s) against which the tenderer has claimed his experience. The tenderer shall attach attested copy(s) of approval issued by the Employer(s) authorizing as a Sub-Contractor; in proof of the claim of the tenderer as a sub-Contractor. The tenderer is also

obliged to produce the original of the certified copy(s) on request by the department.

- iv. Following enhancement factors will be used for the costs of works executed for bringing the financial figures to a common base value in respect of the works completed in the past years.

Table 1

Year before	Multiplying factor
One year	1.07
Two years	1.14
Three years	1.21
Four years	1.28
Five years	1.35
Six years	1.42

- v. **Financial Turnover:**
In proof of Financial Turnover Audited Annual Accounts Statements (Balance Sheet & Profit & Loss Account Statement) & Turnover Certificate signed by the Chartered Accountant or IT returns duly acknowledged by the Income Tax department along with Computation Statement signed by the Chartered Accountant, for the last three years ending on 31st march 2023 shall be produced by the tenderer.

c) Other Eligibility Considerations

Even though the bidders meet the above qualifying criteria, they are subject to be disqualified if they have:

- i. made misleading or false representations in the forms, statements and attachments submitted in proof of the qualification requirements; and/or
 - ii. record of poor performance such as abandoning the works, not properly completing the contract, inordinate delays in completion, litigation history, or financial failures, disqualification/ black listing/ debarring by Govt. departments etc.
- d) The bidders having EPF/ ESI registration certificates only shall be considered for qualification in the tender, if applicable, as per EPF /ESI Acts. In case, the Tenderer does not have the required number of employees which makes such registration mandatory, an Undertaking as per Annexure I to the effect shall be furnished.**

4.7. OPENING AND EVALUATION OF TENDERS

4.7.1 Technical Bids of the tenders received shall be opened at 15.00 hrs. on **01/04/2024**, the last date fixed for receiving the bid, in the Dy.CE's chamber in the presence of the tenderers or their representatives as may be present.

4.7.2 After opening the Technical Bid documents, it shall be thoroughly checked for completeness with respect to the details stipulated to be submitted as Technical

Bid by the tenderer. The Price Bid of those tenderers satisfying the tender requirements shall only be opened. The Price Bid of those tenderers who are found responsive and satisfactory on evaluation of Technical Bid documents, will be opened after bringing all tenderers to the same footing and giving notice to the short listed tenderers, on a date to be decided and intimated later.

4.8 GENERAL INSTRUCTIONS TO TENDERERS

- 4.8.1 The submission of a tender by the tenderer implies that he has read the whole tender Documents including GCC-2016.
- 4.8.2 The tenderer is advised to visit and examine the site of work and its Surroundings, discuss with connected agencies and collect all necessary information on his own responsibility for preparing the tender.
- 4.8.3 The tenderer is expected to examine the Tender Documents including all conditions, specifications, forms etc and also conditions in the G.C.C. Failure to furnish the information required in the Tender Documents/ G.C.C. or submission of a tender not conforming to the requirements in every respect, is likely to result in the rejection of the tender.
- 4.8.4 The tenderer shall quote for the work on percentage basis. The departmental rate for each item of work is given in the Schedule of Quantities. The tenderer shall fill the percentage above or below the Departmental rate, in the column provided for the purpose in the Schedule.
- 4.8.5 In case of discrepancy between the specifications and the drawings, the following order of preference shall be observed:
 - a. Conditions & Specifications of tender
 - b. Drawings.
 - c. B.I.S Specifications.
 - d. Sound Engineering Practice.
- 4.8.6. If there are varying or conflicting provisions made in any document forming part of the Contract, the Chief Engineer, Cochin Port Authority, Cochin-682009 shall be the deciding authority with regard to the intention of the document which will be binding on the tenderer/ Contractor.
- 4.8.7 Any error in description, any omissions there shall not vitiate the Contract or release the Contractor from the execution of whole or any part of the works comprised therein according to specifications or from any of his obligation under the Contract.
- 4.8.8 The Chief Engineer, Cochin Port Authority shall have the right to omit or Suspend certain items of work or revise or amend the Tender Documents at any time prior to the due date of submission of the tender. Such revisions or amendments or extensions if any, shall be communicated to all the bidders who have downloaded the Tender Documents, in the form of an addendum by telefax /e- mail / writing. In order to afford the Bidders with reasonable time to take addendum into account, or for any other reason, the Port Authority may, at its discretion, extend the due date for submission of tender.

- 4.8.9 All payments due to the Contractor under this Contract will be made in Indian Rupees only.
- 4.8.10 Tenders received after the date specified for submission shall not be opened.
- 4.8.11 The Bank Guarantees (BGs) to be furnished by the Contractors in connection with the tender shall be sent to by the Chief Engineer, Cochin Port Authority directly by the issuing bank under registered post with AD. The Contractor shall take the responsibility of sending BGs directly to the Port Authority by the issuing bank.

SIGNATURE OF TENDERER.

5. GENERAL DESCRIPTION AND SPECIAL CONDITIONS OF CONTRACT

1. SCOPE OF WORK

- 1.1 The proposed work is for “**Providing RCC cum Steel Tubular Fender piles at Baggage jetty, Diesel pump jetty, Pilot boat jetty & Embarkation jetty**”. The work consists of the following:
- i. Pulling out broken stumps of fender pile
 - ii. Fabricating, supplying, transporting, pitching & driving 300mm dia. Steel Tubular fender piles.
 - iii. Providing Reinforced cement concrete M30 grade with 20mm metal for precast piles.
 - iv. Filling inside the tubular fender piles with Crusher Run Screening.
 - v. Providing M15 grade Cement concrete for plugging the pile.
 - vi. Painting the outer surface of the Tubular fender pile.
- 1.2 The work shall be meticulously planned in consultation with the departmental supervisory staff and nearby users, so that minimum inconvenience is caused to the functions of the wharf.

2. WORK SITE

The work has to be carried out is at Pilot Jetty, Baggage Jetty & Diesel jetty at Mattancherry Chanel near Marine Building and Embarkation Jetty at Ernakulam Channel near Port Guest House. The site is accessible through road & water. Security rules and regulations including obtaining passes etc. for work are to be observed by the contractor. The work is to be carried out without disturbing the normal Port operations.

3. TIME SCHEDULE AND MONITORING OF PROGRESS

- 3.1 The tenderer shall prepare and attach with the tender a detailed work schedule indicating key activities and critical items for completing the work within the stipulated Contract period of **4 Months**. This time schedule will form the basis for monitoring the progress of work.

4. MATERIALS / FACILITIES TO BE PROVIDED BY DEPARTMENT

4.1. CONTRACTOR'S WORK AREA

Space will be made available to the Contractor free of rent for storing materials and equipments etc., adjacent to the work site for the duration of the Contract. After the work is over, Contractor shall at his cost, reinstate the area by clearing the temporary works, debris etc. as decided by the Engineer's Nominee.

5. CONTRACTOR'S RESPONSIBILITY

- 5.1 The tenderer shall visit the area before tendering. It will be deemed that the tenderer has visited the site and studied the site conditions before submitting the tender. The tenderer should get himself acquainted with the nature and extent of the work. No claim whatsoever will be entertained on the plea of ignorance of difficulties involved in execution of work or carriage of materials etc.
- 5.2 All materials, plants and equipments, required for the work shall be provided by

- the Contractor at his own cost, and shall conform to relevant I.S. Specification unless otherwise specified.
- 5.3 Samples of all materials, to be incorporated in the work shall be got approved by the Engineer's Nominee before procurement.
 - 5.4 The Contractor shall thoroughly study the specifications and errors / omissions/modifications if any shall be brought to the notice of the Engineer – in-Charge well in advance so that a final decision in the matter could be given in time.
 - 5.5 All labour, skilled or unskilled shall be provided by the Contractor. Settling any dispute with the labour will be Contractor's responsibility. Insurance as per Indian Workmen's Compensation Act for the Contractors' workmen and Public Liability Policy shall be provided by the Contractor at his own cost.
 - 5.6 The Contractor shall be solely responsible for any damage or injury to the persons or things caused or suffered during the execution of the work and shall be made good or compensated at his own cost.
 - 5.7 The Contractor shall take all care and precautionary measures for avoiding any kind of damage/accidents in the work site due to any of his reasons. The Contractor shall indemnify the Port against any compensation whatsoever payable to the workmen for accident or loss arising out of and in the course of their employment under this Contract.
 - 5.8 The work shall be arranged by the Contractor without causing any damage to Port structures. Any damage or accident caused by the Contractor's operation shall be compensated / made good at Contractor's risk and cost to the satisfaction of the Engineer's Nominee of the works, failing which department will do the rectification work and the cost incurred will be recovered from his bill or from security deposit.
 - 5.9 The Contractor shall not construct any structure, even of temporary nature, for any purpose at site, except with the written permission of the Engineer's Nominee of the work and any construction so put up shall be removed by the Contractor whenever the Engineer's Nominee calls upon the Contractor to do so.
 - 5.10 The Contractor shall remove all temporary works, clear and make good the site, at his cost to the satisfaction of the Engineer's Nominee before the site is returned to the Port Authority. All materials shall be disposed to any place as pointed out by the Engineer's Nominee of the work and site shall be cleared in every respect at no extra cost after completion of work.
 - 5.11 The Contractor shall remove all materials brought to work site / stacked at the work site or anywhere else within the Port area and clear the site at his cost to the full satisfaction of the Engineer's Nominee before the site is returned to the Port Authority. All such materials including debris, tools & plants etc. shall be disposed off to any place as pointed out by the Engineer's Nominee or be taken away from the location and shall be cleared in every respect and to reinstate to its original condition at no extra cost to the Port Authority immediately after completion of

- the work. In case, any such material is found left in the work site or anywhere in the Port area, rent for the storage space occupied by the Contractor, either for stacking the materials /debris or for areas used for such purpose but not cleared thereafter, will be recovered as per the prevailing Scale of Rate of Cochin Port Authority, for the rent applicable for open storage space for commercial purpose, for the period for which the area had been occupied by the Contractor. In addition to the above, in case the Port requires the area immediately for its use, Port will repossess the land after restoring it to its original condition, material will be confiscated and disposed off at the risk and cost of the Contractor, after issuing two notices giving 15 days' time each for removing the material. All expenses incurred in this shall be recovered by disposing off the material if any confiscated. If any balance amount still remains to be realized that will be recovered from the Contractor by appropriate means.
- 5.12 The Contractor shall observe all safety regulations during the execution of the work. Safety measures, precautions, warning signals etc. shall be taken/provided at the Contractor's cost, as directed by the Engineer-in-Charge of the work. The Contractor shall provide all necessary personnel protection equipments such as helmet, lifeguard, goggles, boots, safety belts etc. to the workmen at his own cost and it shall be the Contractor's responsibility to ensure that they use it while on the work site.
- 5.13 The Contractor shall ensure that no labourers with criminal background are engaged for the work.
- 5.14 The contractor shall take all precautions for not to damage any cables, pipelines etc. passing through the area of work.
- 5.15 The Contractor shall comply with all the provisions of the Indian Workmen's Compensations Act, Public Liability Policy, Provident Fund Regulations, Employees Provident Fund and ESI Act etc. amended from time to time and rules framed there under and other laws affecting the Contract labour that may be brought in to force from time to time.
- 5.16 The bidders having EPF/ ESI registration certificates only shall be considered for qualification in the tenderers, if applicable, as per EPF /ESI Acts. In case, the Tenderer does not have the required number of employees which makes such registration mandatory, an Undertaking as per Annexure I to the effect shall be furnished..**
- 5.17 The Contractor shall provide, at every work place, at which 20 or more women workers are ordinarily employed, crèches of reasonable size and with adequate facility for the use of their children under the age of six years at his risk and cost.
- 5.18 The Contractor shall also be responsible for arranging and carrying out works as mentioned in Clauses 1.1 & 1.2 above.
- 5.19 Defect Liability period of the work is one year from the date of completion of the work.**

6. POWER AND WATER

- 6.1 Electric power required for the work can be supplied by the department from the nearest existing line of the Port Authority at prevailing rates. The cost of drawing temporary lines/ cables/ providing switches and making connection and metering arrangements etc, shall be borne by the Contractor. If there is any disruption in the power supply due to supply failure/ restrictions imposed by the Kerala State Electricity Board, the department shall not be held responsible and the Contractor has to make suitable alternative arrangements at their cost.
- 6.2 Water required for the work shall be arranged by the Contractor at his own cost.

7. WORKMANSHIP

- 7.1 All the works shall be done strictly according to relevant B.I.S. specifications unless otherwise specified. Whenever special conditions and other specifications deviate from the B.I.S. the former shall prevail.
- 7.2 The whole work shall be completed in a diligent manner within the Contract period and defect or imperfection if any, observed during the Defect Liability Period/ guarantee period the same shall be rectified at Contractor's cost to the full satisfaction of the Engineer's Nominee within the time allowed.
- 7.3 Precautions shall be taken for not to damage cables/ pipe lines etc.
- 7.4 The work shall be arranged in the order of preference and as directed by the Engineer's Nominee of work.

8. TEMPORARY WORKS

- 8.1 All scaffolding, staging, bracing and other temporary works required for proper execution of the works, shall be provided by the Contractor at his own cost, unless stated otherwise and that should be inclusive of all materials, labour, supervision and other facilities. The layout and details of such temporary works shall have prior approval of the Engineer's Nominee, but the Contractor shall be responsible for proper strength and safety of the same. All temporary works shall be so constructed as not to interfere with any permanent work or with the work of other agencies. If it is necessary to remove any of the temporary works at any time to facilitate execution of works or work by other agencies, such removal and re erection, if required, shall be carried out by the Contractor at the direction of Engineer's Nominee without any delay and any extra cost on this account shall be borne by the Contractor.
- 8.2 On completion of the works, temporary works if any provided by the Contractor shall be removed from the site and the area shall be reinstated to the original condition at his own risk and cost.

9. TIME FOR COMPLETION

- 9.1 The time allowed for carrying out the work as mentioned in the memorandum shall be strictly observed by the Contractor. The work shall throughout the time period be proceeded with diligence, time being deemed to be the essence of the Contract. The number of days lost due to heavy rain shall be certified by the

Engineer's Nominee. The Contract period shall be extended for such certified days also without imposing compensation for delayed performance.

9.2 The whole work shall be completed in accordance with the provisions under Contract Data or such extended time as may be allowed as per clause 29 of G.C.C.

10. WORKING TIME

The normal working time of the Port Authority is from 8 a.m. to 4.00 p.m. on all weekdays. If the Contractor wishes to carry out the work beyond normal working hours and or on holidays, he should get specific approval from the Engineer's Nominee for the same. Necessary supervision will be arranged by the department and the expenditure to be incurred in this connection will be borne by the department.

11. RATES FOR VARIOUS ITEMS

The rate specified for each item shall be all inclusive value of the finished work, income tax and other taxes but excluding Service Tax.

12. ALTERATIONS / ADDITIONS / OMISSIONS

The quantities given in the bill of quantities (Schedule of items) are only approximate and payment will be made as per actual quantity of work done and rate specified.

13. MEASUREMENT

The quantities shall, unless otherwise stated, be measured in accordance with I.S.1200.

14. For levying compensation as per Clause-49 of General Conditions of Contract (GCC), the Employer is not required to have documentary evidence to quantify or prove the losses suffered by the Employer due to delay in completion of work by the Contractor, as per conditions.

15. Clause-25 of GCC- 'Settlement of Disputes and Arbitration' is not applicable in this Contract.

16. Clause-26 of GCC- 'Computerised Measurement Book' is modified to the extent as detailed below.

Measurements of Work Done:

Executive Engineer (hereinafter called the Engineer's Nominee) shall, except as otherwise provided, as certain and determine by measurement the value in accordance with the Contract of work done.

All measurement of all items having financial value shall be entered in Measurement Book and/or level field book so that a complete record is obtained of all works performed under the Contract.

All measurements and levels shall be taken jointly by the Engineer's Nominee or his authorised representative and by the Contractor or his authorised representative from time to time during the progress of the work and such measurements shall be signed and dated by the Engineer's Nominee and the Contractor or their representatives in token of their acceptance. If the Contractor objects to any of the

measurements recorded, a note shall be made to that effect with reason and signed by both the parties.

If for any reason the Contractor or his authorised representative is not available and the work of recording measurements is suspended by the Engineer's Nominee or his representative, the Engineer's Nominee and the Department shall not entertain any claim from Contractor for any loss or damages on this account. If the Contractor or his authorised representative does not remain present at the time of such measurements after the Contractor or his authorised representative has been given a notice in writing three (3) days in advance or fails to countersign or to record objection within a week from the date of the measurement, then such measurements recorded in his absence by the Engineer's Nominee or his representative shall be deemed to be accepted by the Contractor.

The Contractor shall, without extra charge, provide all assistance with every appliance, labour and other things necessary for measurements and recording levels.

Except where any general or detailed description of the work expressly shows to the contrary, measurements shall be taken in accordance with the procedure set forth in the specifications notwithstanding any provision in the relevant Standard Method of measurement or any general or local custom. In the case of items which are not covered by specifications, measurements shall be taken in accordance with the relevant standard method of measurement issued by the Bureau of Indian Standards and if for any item no such standard is available then a mutually agreed method shall be followed.

The Contractor shall give not less than seven days' notice to the Engineer's Nominee or his authorised representative in charge of the work before covering up or otherwise placing beyond the reach of measurement any work in order that the same may be measured and correct dimensions thereof be taken before the same is covered up or placed beyond the reach of measurement and shall not cover up and place beyond reach of measurement any work without consent in writing of the Engineer's Nominee or his authorised representative in charge of the work who shall within the aforesaid period of seven days inspect the work, and if any work shall be covered up or placed beyond the reach of measurements without such notice having been given or the Engineer's Nominee's consent being obtained in writing the same shall be uncovered at the Contractor's expense, or in default thereof no payment or allowance shall be made for such work or the materials with which the same was executed.

Engineer's Nominee or his authorised representative may cause either themselves or through another officer of the department to check the measurements recorded jointly or otherwise as aforesaid and all provisions stipulated herein above shall be applicable to such checking of measurements or levels.

It is also a term of this Contract that recording of measurements of any item of work in the measurement book and/or its payment in the interim, on account or final bill shall not be considered as conclusive evidence as to the sufficiency of

any work or material to which it relates nor shall it relieve the Contractor from liabilities from any over measurement or defects noticed till completion of the defects liability period.

17. Clause 45 and Clause 80 of GCC shall be modified as below;

Clause 45-Rates for items to be inclusive of Taxes The rate quoted by the Contractor shall be inclusive of the cost of provision of plant and equipment, materials, labour, execution, supervision, maintenance, overheads and profits and every incidental and contingent cost and charges whatsoever excluding Goods and Service Tax (GST). GST as may be applicable from time to time shall be shown separately in the invoice. The Employer will perform such duties in regard to the deduction of such taxes at sources as per applicable law. Any new Taxes, levies, duties imposed after signing the Contract shall be reimbursed by the Employer on production of documentary evidence. The invoice to be submitted by the Contractor should include the GST Registration Number of the Contractor as well as the Employer.

Clause 80-Taxes and Duties Income Tax The Contractor and his staff shall be responsible for payment of all personal income taxes to the concerned authorities as per the law in force from time to time. Deduction of Income Tax shall be made by the Employer from each certificate of payment to the Contractor as per the prevailing rate plus surcharge or such other rates as may be specified by the Central Government from time to time, on the gross amount of the Contractor's bill for payment. The Contractor shall comply all the GST Regulations viz. timely uploading of bills, issue of debit/ credit notes etc.

18. Sub clause 43.2 under Clause 43:Payments,..... in GCC 2016 stands amended as given below:

43.2 Payment of bills for Civil Works shall be regulated as detailed hereunder:

43.2.1 Any Interim/Final bill which is incomplete in any respect shall be returned to the Contractor within 5 days of date of submission of bill to the Engineer or his Nominee.

43.2.2 Interim bills shall be paid within 21 days of date of submission of bills in full shape, by the Contractor, as detailed below.

43.2.3 Clarifications/corrections if any required on an Interim bill submitted, shall be sought from the Contractor within 4 days of submission of the bill and also, all such clarifications/corrections required shall be sought at one go except in exceptional circumstances. The Contractor shall submit the clarifications including carrying out corrections in the bill, if required, within 4 days thereafter. The clarified / corrected bill shall be verified and forwarded to Finance Department within the next 4 days. Clarifications if any required by the Finance Department shall be sought within 3 days and the Engineer/Nominee shall clear it on top priority within the next 3 days and, finally, the bill shall be paid to the Contractor within 3 days thereafter, i.e., within a total 21 days of

date of submission of bills in full shape, as indicated above.

43.2.4 However, on request by the Contractor, 75% of the bill amount shall be paid within 7 days of submission of the bill. Balance amount of the verified bill shall be paid within 21 days of the submission of the bill, on completion of all contractual requirements as brought out at sub clause 43.2.3. above.

43.2.5 Final bill shall be paid within 3 months of issue of Taking Over Certificate by the Engineer / Nominee, as detailed below.

43.2.6 The Contractor shall submit the Final bill to the Engineer / Nominee within 20 days of issue of Taking Over Certificate by the Engineer / Nominee. The bill shall be checked and all clarifications/corrections required on the bill submitted, shall be sought from the Contractor within 15 days thereafter. The Contractor shall submit the clarifications including carrying out corrections in the bill, if required, within the next 10 days. The clarified / corrected bill shall be verified and forwarded to Finance Department within the next 15 days. Thereafter, clarifications if any required by the Finance Department shall be sought within 10 days and the Engineer/Nominee shall clear it on top priority within the next 10 days and, finally, the bill shall be paid to the Contractor within 10 days thereafter, i.e., within a total 3 months of issue of Taking Over Certificate by the Engineer / Nominee, as indicated above.

43.2.7 However, on request by the Contractor, 50% of the final bill amount shall be paid within 7 days of submission of the bill, which will be adjusted against the final bill payment, on completion of all contractual requirements as brought out at sub clause 43.2.6. above.

19. Any disputes and differences between the parties shall be resolved in the Jurisdiction of Courts in Cochin alone.
20. In case of any contradiction between the Clauses in Tender Document and that in GCC, the clauses in the tender document shall prevail.

SIGNATURE OF TENDERER

6. DETAILED SPECIFICATIONS FOR MATERIALS TO BE USED ON WORK

6.1 GENERAL

- 6.1.1 Except where otherwise specified or authorized by the Engineer-in-Charge, materials supplied by the contractor shall conform to the latest edition of the Indian Standard Specifications and code of practices published by the Indian Standard Institution. Samples of materials to be supplied by the contractor shall be shown to the Engineer-in-Charge sufficiently in advance for approval of its quality for use on the work.
- 6.1.2 All materials supplied shall be stored appropriately to prevent deterioration/ damage from any cause what so ever and to the entire satisfaction of the Engineer-in Charge.
- 6.1.3 The materials required for the work shall be brought to the site and stacked at the places shown by the Engineer-in-Charge and the same shall be got approved for use in work sufficiently advance so that the progress of the work is not affected by the supply of materials.
- 6.1.4 Payment for the materials supplied, shall be given only after they are used on the work.
- 6.1.5 Tolls are payable by the Contractor as per rules for vehicles using the Port's road for supplying the materials.

6.2 CEMENT

- 6.2.1 Quality of cement used for the Work shall be 43 grade ordinary Portland cement conforming to IS:8112 or 53 grade ordinary Portland cement conforming to IS:12269 or Pozzolona cement conforming to IS:1489 unless otherwise approved by the Engineer-in-Charge.
- 6.2.2 The cement required for the Work will have to be procured by the Contractor and shall comply with the relevant IS. As far as possible, the cement required for the Work will have to be procured from the government agencies. The cement shall, if required by the Chief Engineer / Engineer-in-Charge, be tested and analyzed by an independent analyst at the Contractor's cost and result produced to the Engineer-in-Charge.
- 6.2.3 Supply of cement shall be taken in 50kg bags bearing manufacture's name and ISI marking. Samples of cement arranged by the Contractor shall be taken by the Engineer-in-Charge and got tested in accordance with provisions of relevant BIS codes. In case, test results indicate that the cement arranged by the Contractor does not conform to the relevant BIS codes, the same shall stand rejected and shall be removed from the site by the Contractor at his own cost within a week's time of written order from the Engineer-in-Charge to do so.
- 6.2.4 A cement godown of adequate capacity as directed by the Engineer-in-Charge shall be constructed by the Contractors at the site of the Work for which no extra payment shall be made. Double lock provision shall be made to the door of the cement godown. The key of one lock shall remain with the Engineer-in-Charge or his authorized representative and the key of the other lock shall remain with the

Contractor. The Contractor shall be responsible for the watch and ward and safety of the cement godown. The Contractor shall facilitate the inspection of the cement godown by the Engineer-in-Charge.

6.2.5 The cement brought to the site and cement remaining unused after completion of Work shall not be removed from the site without written permission from /of the Engineer-in-Charge.

6.2.6 The cement shall be stored in a weather proof building with facilities for inspection.

6.2.7 The Contractor shall maintain a cement register showing dates of receipt and issue, quantities used daily and balance which shall be accessible to the Engineer-in-Charge.

6.3 WATER

6.3.1 Clean fresh water free from oils, acids, alkalies, salt, sugar, organic materials or other harmful materials shall be used for washing aggregates, mixing and curing of concrete. The water used shall comply with clause 5.4 of IS:456-2000. Potable water is generally considered good for mixing concrete.

6.3.2 Cochin Port will not provide/ supply water for the Work. Water has to be arranged by the Contractor himself for the construction works including curing work **at his own risk and cost.**

6.3.3 Samples of water arranged by the Contractor shall be taken by the Engineer in Charge and got tested in accordance with the provisions of relevant BIS codes. In case test results indicate that the water arranged by the Contractor does not conform to the relevant BIS codes, the same shall not be used for any Works. The cost of tests shall be borne by the Contractor.

6.4 AGGREGATES FOR CONCRETE

6.4.1 Aggregates (fine and coarse) for concrete shall comply with the requirements of IS:383 – ‘Specifications for coarse and fine aggregate from natural sources for concrete’. Aggregate shall be obtained from sources approved by the Engineer-in-Charge. Aggregates, which are not perfectly clean, shall be washed in clean water to the entire satisfaction of the Engineer-in-Charge.

6.4.2 The fine aggregate shall be clean, hard, durable, uncoated, dry and free from injurious, soft or flaky pieces and organic or other deleterious substances.

6.4.3 Each type of aggregate shall be stored separately for the approval of Engineer-in-Charge. Wet aggregate delivered at the site shall be kept in storage for at least 24 hours to ensure adequate drainage before being used for concreting.

6.4.4 Contractor shall maintain at site at all times such quantities of each type of aggregate as are considered by the Engineer-in-Charge to be sufficient to ensure continuity of Work.

6.5 CRUSHER RUN SCREENING

6.5.1 Crusher run screening shall pass 90 to 100% through 4.75 mm sieve and 0 to 10% by weight pass through 150 micron IS sieve. The same shall be clean, hard, durable, uncoated, dry and free from injurious soft or flaky piece and organic or other deleterious substances..

6.6 MILD STEEL PLATES

6.6.1 Mild steel plate used for fabrication of tubes shall conform to IS 226 and shall be in single piece.

6.7 STRUCTURAL STEEL

6.7.1 Angles, ISMB and plates used for the work shall conform to IS: 2062. It shall be free from visible as well as manufacturing defects such as pitting , cracks, laminations, twists etc and excessive rusting.

6.7.2 Structural steel used shall be of TATA make. It shall be free from visible as well as manufacturing defects such as pitting, cracks, laminations, twists etc. and excessive rusting. MS angles shall conform to IS. The plates shall conform to IS 226. The angles & plates shall be free from visible as well as manufacturing defects such as pitting, cracks, laminations, twists etc. and excessive rusting.

6.8 MATERIALS NOT SPECIFIED

6.8.1 All materials not herein detailed and fully specified but which may be required for use on works, shall be subjected to the approval of the Engineer-in-Charge without which they shall not be used anywhere in the permanent works.

6.9 SAMPLING AND TESTING OF MATERIALS

6.9.1 Sampling and testing of the material supplied by the contractor for use on the Work shall be done as per the provisions of the relevant BIS codes/specifications. In the absence of BIS specification in a particular case, the sampling and testing shall be done as directed by the Engineer-in-Charge as per sound engineering practice. Material conforming to the specifications and approved by the Engineer-in-Charge shall only be used by the Contractor.

6.9.2 All the sampling and testing shall be done at the Contractor's cost.

SIGNATURE OF TENDERER

7. DETAILED SPECIFICATIONS FOR ITEMS OF WORKS

7.1 GENERAL

7.1.1 Except where otherwise specified or authorized by the Engineer-in-Charge, all items of works executed by the contractor shall conform to the latest edition of the Bureau of Indian Standard Specifications and code of practices published by the B.I.S. Where no such specifications or code of practice exists the latest B.S.S. codes of practice or any other equivalent / standard code of practice shall also be considered for adoption. The tenderer while indicating any such specifications shall enclose the full set of the publication so referred and not in extracts. Photostats / Xerox copies in duplicate shall be forwarded which shall not be returned to the contractor. In absence of any specification, the department reserves the right to adopt trade specifications and/or sound engineering practices for the specialized work as may be decided by the Engineer-in-Charge which shall be final, conclusive and binding on the contractor.

7.2 PLAIN AND REINFORCED CEMENT CONCRETE

7.2.1 General

The concrete used for all Works, concreting procedure etc. shall be in accordance with IS:456–2000.

7.2.2 Concrete Mix

Mix used for R.C.C. shall be of minimum M20 grade unless otherwise specified. Design mix shall be used for M20 and higher grade of concrete unless otherwise specified in the schedule.

7.2.3 Nominal Mix

For nominal mix concrete, proportion of fine aggregate to coarse aggregate shall be 1:2 by volume. The minimum cement content per cubic metre of nominal mix concrete shall be as given below.

Sl. No	Type of concrete	Cement content per Cu. M
1	Cement concrete M15 Grade (20 mm size graded metal)	320 Kg.

7.2.4 Design Mix

7.2.4.1 For **design** mix concrete of following grades of concrete the minimum cement content per cubic metre and maximum water cement ratio are as given below.

Sl. No	Grade of Concrete	Minimum cement content in Kg / m ³	Maximum free Water cement ratio
1	M30	340	0.55

7.2.4.2 For design mix concrete, the Contractor shall make calculations jointly with Engineer-in-Charge and carry out all necessary tests at Contractor's cost to

determine the proportion by weight of cement, aggregates (coarse and fine), admixture if required and water necessary to produce concrete of required grade having the desired Workability and, water cement ratio not exceeding the allowable limit, prior to commencement of Work. The Contractor shall submit the following for the approval of Engineer-in-Charge.

- (i) The proportion of cement, coarse aggregate, fine aggregate and water so determined.
- (ii) The sieve analysis of aggregates which he proposes to use in the Works.
- (iii) Full details of the tests conducted.
- (iv) All calculations relevant to mix design.

7.2.4.3 When the proportions are submitted to the Engineer-in-Charge which he considers will produce concrete having the required properties, it shall become the declared proportions to be used for the Work. The Agreement by the Engineer-in-Charge to such declared proportions shall not relieve the Contractor of any of his responsibilities to use in the Work at all times concrete having the required properties. No deviation from the declared proportions shall be allowed unless and until the Engineer-in-Charge shall have given his written authorisation for the adoption of revised proportions for the concrete.

7.2.4.4 Sampling, testing and acceptance criteria for designed mix concrete shall be as per clause 15, 16 & 17 of IS:456 - 2000 unless otherwise specified. Sampling and testing shall be done at Contractor's own cost. Testing shall be done in a laboratory approved by the Engineer-in-Charge.

7.2.5 Size of Coarse Aggregate

7.2.5.1 For all concrete, plain or reinforced of M20 and higher grades, 20 mm size graded aggregate conforming to IS:383 shall be used unless otherwise specified. If 20 mm graded aggregates as per IS:383 are not readily available, graded 20 mm aggregate shall be obtained by blending 20 mm and 12.5/ 10 mm aggregates in the proportion arrived based on the combined sieving of aggregates.

7.2.6 Mixing of Concrete

7.2.6.1 Concrete shall be mixed in a drum or pan type batch mixer, the type and capacity of which is to be approved by the Engineer-in-Charge. Time allowed for mixing, after all ingredients have been placed in the mixers shall not be less than two minutes. If there is segregation after unloading from the mixer, the concrete should be remixed.

7.2.6.2 Ready mix concrete from outside source shall be allowed for use on the work subject to the conditions that: (i) written permission shall be obtained from the Engineer-in-Charge, (ii) all quality control measures as stipulated by the Engineer-in-Charge are strictly adhered to by the Contractor at his cost, (iii) all design mix calculations as per Clause 2.3.4 of Tender Document shall be submitted by the contractor for approval of the Engineer-in-Charge & approval

obtained; and (iv) all expenses towards conveyance and incidentals of providing departmental supervision at the mixing plant shall be borne by the Contractor.

7.2.7 Assembly of reinforcement for Reinforced Cement Concrete.

7.2.7.1 The steel bars used for reinforcement Works shall be either mild steel bars conforming to IS:432 (Part I) or HYSD bars, conforming to IS:1786 (Grade Fe 500 / Fe 415) or both

7.2.7.2 The Contractor shall, when ordered, submit to the Engineer-in-Charge the detailed bar bending schedule for his scrutiny and approval sufficiently in advance (about four weeks) of the due date of commencement of the relevant items of Works. While Working out the bar bending schedule, the Contractor shall ascertain the length of bars likely to be made available to him and the schedule shall be so made, keeping the wastage/ cut bits of bars to bare minimum without hampering technical requirements. If the size of the steel bars specified in the drawing or schedule is not available, the nearest size available shall be used. Revised drawing shall be issued to the Contractor substituting the new size of reinforcement and bar bending schedule shall be prepared by the Contractor accordingly. No extra payment shall be made to the Contractor for making this substitution. The fabrication of reinforcement shall commence only after the bar bending schedule is approved by the Engineer-in-Charge.

7.2.7.3 Reinforcement shall be cut to the exact length and made truly straight and then bent to the exact shape and dimensions as indicated in the drawings. The bending and fixing of bars shall be done in accordance with IS:2502 unless otherwise specified.

7.2.7.4 All cut bits of steel are the property of the Contractor. However, the Contractor can dispose them off only with the permission in writing of the Engineer-in-Charge. If the department requires the cut lengths, they are to be handed over to the department and will be paid for at the rates at which they were purchased by the Contractor.

7.2.7.5 The reinforcement shall be cleaned by wire brush etc. to remove oil, grease, loose mill scale, loose rust or other deleterious matter that may reduce or destroy bond etc. before tying in position and also immediately before placing the concrete.

7.2.7.6 All reinforcement shall be placed and maintained in accordance with the drawings. Tolerance on placing of reinforcement shall be in accordance with clause 12.3 of IS:456-2000. Bolts, nuts, washers and rivets etc. required for complete erection of reinforcement and keeping in position shall be supplied by the Contractor at his own cost.

7.2.8 Form Work

7.2.8.1 The steel/ marine plywood formwork shall be used for concrete work. The form work shall be designed and constructed to the shape, lines and dimensions shown in the drawings within the tolerance limit and specified in clause 11.1 of IS:456-2000. Joints of the form works shall be made water tight by providing suitable beadings / gasket as approved by the Engineer-in-Charge. All rubbish,

particularly chippings, shall be removed from the interior of the forms before the concrete is placed and the form work in contact with the concrete shall be cleaned and thoroughly wetted or treated with an approved composition. Care shall be taken that such approved composition is kept out of contact with the reinforcement.

- 7.2.8.2 Before reuse, all forms shall be thoroughly scraped, cleaned, nails removed, holes that may leak suitably plugged and joints examined and when necessary, repaired and the inside retreated to prevent adhesion, to the satisfaction of Engineer. Warped timber shall be resized. Contractor shall equip himself with enough shuttering material to complete the job in the stipulated time.
- 7.2.8.3 Forms for sloped surfaces shall be built so that the formwork can be placed board -by- board immediately ahead of concrete placement so as to enable ready access for placement, vibration inspection and repair of the concrete. The formwork shall also be built so that the boards can be removed one by one from the bottom up as soon as the concrete has attained sufficient stiffness to prevent sagging. Surfaces of construction joints and finished surfaces with slopes steeper than 4 horizontal: 1 vertical shall be formed as required herein.
- 7.2.8.4 For forms for curved surfaces, the Contractor shall interpolate intermediate sections as necessary and shall construct the forms so that the curvature will be continuous between sections. Where necessary to meet requirements for curvature, the form timber shall be built up of laminated splines cut to make tight, smooth form surfaces. After the forms have been constructed, all surface imperfections shall be corrected and all surface irregularities at matching faces of form material shall be dressed to the specified curvature.
- 7.2.8.5 Care shall be taken to see that the faces of formwork coming in contact with concrete are perfectly cleaned and two coats of mould oil or any other approved material applied before fixing reinforcement and placing concrete. Such coating shall be insoluble in water, non-staining and not injurious to the concrete. It shall not become flaky or be removed by rain or wash water. Reinforcement and/or other items to be cast in the concrete shall not be placed until coating of the forms is complete; adjoining concrete surface shall also be protected against contamination from the coating material.

7.2.9 **Cover to Reinforcement**

- 7.2.9.1 Cover as specified in drawing shall be provided by using precast cement concrete block made from concrete of same grade as that of main Work unless otherwise directed by the Engineer-in-Charge.

7.2.10 **Transporting, placing, compacting and curing of concrete**

- 7.2.10.1 Transporting, placing, compacting and curing of concrete shall be as per clause 13 of IS:456-2000.
- 7.2.10.2 Concrete shall be transported from the mixer to the Worksite as rapidly as possible which will prevent the segregation or loss of any ingredient, and for maintaining the Workability.

- 7.2.10.3 The concrete shall be placed and compacted before setting commences and should not be subsequently disturbed. Care should be taken to avoid displacement of reinforcement or movement of formwork.
- 7.2.10.4 All concrete shall be vibrated unless otherwise specified or approved by the Engineer-in-Charge and such vibrating shall be as required by the Engineer-in-Charge. The mechanical vibrators complying with IS:2505, IS:2506 or IS:4656 shall be used for compacting concrete. All vibrations shall be carried out to a plan approved by the Engineer-in-Charge. No Workman shall be allowed to operate the vibrator without having received instructions and training in its use. Care must be taken to avoid segregation and excessive vibration.
- 7.2.10.5 Concreting shall be carried out continuously upto construction joints, the positions and arrangement of which shall be as directed by the Engineer-in-Charge. When the Work has to be resumed the construction joints shall be prepared in accordance with clause 13.4 of IS:456-2000.
- 7.2.10.6 Unless otherwise specified, all concrete shall be kept continuously in a damp condition by ponding or by covering with a layer of sacking, canvas, hessian or similar materials with fresh water for not less than 7 days after laying the concrete. If curing is not done properly the department will be at liberty to engage labour for curing and the expenditure incurred will be recovered from the Contractor's bill. The decision of the Engineer-in-Charge will be final on this.
- 7.2.10.7 Stripping time for the formwork shall be as stipulated in clause 11.3 of IS:456-2000. Any impression, fins etc. that may occur from the formwork shall be removed and treated with cement mortar 1:1.5 (1 cement: 1.5 sand).
- 7.2.10.8 Contractor shall arrange to fix any fixtures wherever necessary while doing concreting Work without any extra cost. Cost of fixtures will be paid separately, if it is provided by the Contractor.
- 7.2.11 The unit rate quoted by the tenderer shall be for the finished Work and deemed to include cost of all materials and labour, provision of holes, recess, other contingent items etc. required for the completion of Work but excluding shuttering as specified in the schedule etc.

7.3 **FABRICATING MILD STEEL TUBES**

- 7.3.1 The plates used for fabrication of tubes shall conform to IS 2063, IS 226.
- 7.3.2 All tubes shall be fabricated to the length shown in the drawings or as directed by the Engineer-in-charge. The tubes shall be fabricated to full lengths as ordered by the Engineer-in-charge at the fabrication yard itself and no field joints shall be permitted.
- 7.3.3 The cutting of plates to exact sizes to suit the diameter of piles may be carried out by any method acceptable to the Engineer-in-charge. Bevelling may be done by mechanical grinding or sawing. The use of mechanically guided frame cutting may be permitted. The external diameter of the tube shall be 300mm. The Engineer-in-charge may modify the tube requirement if found necessary during the execution of work.

- 7.3.4 The edges to be welded shall be properly cleaned. All paints, oil, grease, rust oxides in general shall be removed, as well as foreign matter which could be detrimental to the welding. Ends shall be totally dry when welded.
- 7.3.5 The rolling of pipes shall be carried out by any recognised method of rolling which shall be acceptable to the Engineer-in-charge. The plates shall be cut, edges prepared for welding and rolled into shells equal to the outside diameter of the piles. The opposite edges of plates after rolling shall meet in perfect alignment to form a true reduced joints longitudinally without any sudden change in the radius at the junction.
- 7.3.6 Joints welding may be done either by manual metal arc welding process or by automatic submerged arc welding process as approved by the Engineer-in-charge. Subject to approval of the Engineer-in-charge. Welding shall conform to the standard code of practice as adopted to India. Metal arc welding of steel in general shall be in accordance with IS 816 “Code of practice for use of metal arc welding for general construction in mild steel. Filler materials shall be of A type and make approved by the Engineer-in-charge. The contractor shall submit manufacturers test certificates for each batch of filler materials supplied by them.
- 7.3.7 Only equipments and plants approved by the Engineer-in-charge shall be employed for the work. Payment for supply of MS tube shall be made on weight basis. The weight of tube shall be calculated at the rate of 7.85 grams per cubic centimetre of tube wall. No allowance shall be given for the projection of weld material.
- 7.3.8 The tubes fabricated in the contractor’s fabrication yard at the site or readymade tubes supplied by the reputed fabricators may be used on the work in case the contractor proposes to use tubes supplied by the reputed fabricators, the details of such fabricators shall be made available to the Engineer-in-charge to access about the capacity of the firm and the quality of their products and tubes shall be procured only from these fabricators who are approved by the Engineer-in-charge for the purposes.

7.4 **TRANSPORTATION AND DRIVING OF PILES**

- 7.4.1 All plants, machineries, cranes, equipments other accessories, platform floaters, temporary works etc. including consumables required for transporting pitching and driving of piles shall be arranged by the contractor at his cost. After completing transporting pitching and driving of piles, all the plants, machineries etc. including temporary works shall be removed from the site and cleared as directed by the Engineer-in-charge.
- 7.4.2 The area of installation of piles including shallow area the contractor shall arrange dredging, if required for producing necessary water depth for the floatation of pile driver and facilitating pitching the pile without any extra cost.
- 7.4.3 The number of days that the piles will have to be kept in casting yard for curing before they are removed from the casting bed for driving shall be as decided by the Engineer-in-charge. In case any dispute arises on this point, the decision of the Chief Engineer shall be final.

- 7.4.4 When the piles are lifted then transported they should be suspended or supported only at the toggle holes provided for the purpose. The lifting and transporting should be done only with suitable sling attached to the bolts to be placed in the toggle holes (at the time of lifting). If necessary additional supports between the toggle holes may also be provided in consultation with the Engineer-in-charge to avoid cracking and other damages, bumping and other heavy blows should be avoided at all cost.
- 7.4.5 For transporting piles to the site of pitching and driving, the contractor shall bring his own floats and other equipments required for the purposes.
- 7.4.6 To prevent the top of the piles from being damaged during driving a cushion of soft packing should be interposed between the helmet and the top of the pile. The packing shall be felt coir mats, coir ropes, sacks, asbestos fiber or saw dusting bags. It is important that the cushion should with truly over the top of the pile in order that the force from the hammer blow may be evenly distributed.
- 7.4.7 All piles shall be driven in correct position and alignment. All additional works that may become necessary due to defective driving of pile etc. should be done at the expense of the contractor. If any pile is broken or damaged while driving the contractor should remove such piles and drive another at the same place without any extra cost.
- 7.4.8 The entire operations of transporting and pitching and driving of piles shall be measured under one item for payment purpose. The pile shall be transported, pitched and driven to required depth as directed by the Engineer-in-charge.
- 7.5 **PAINTING OF STEEL TUBES**
- 7.5.1 The protective coat of steel tubes will consists of a single coat of heavy duty primer plus two top coats of coal tar Epoxy paint.
- 7.5.2 Zinc Anode 304 supplied by the Berger paints or equivalent Zinc filled self curing inorganic heavy duty primer based or Ethyl Sylicate supplied by other manufacturers approved by the Engineer-in-charge shall be used for the primer coat.
- 7.5.3 For top coat EPILUX 555 coal tar Epoxy supplied by Berger paints or equivalent coal tar Epoxy supplied by other manufacturers as approved by the Engineer-in-charge shall be used for the top coat.
- 7.5.4 A thinner may be used only where permitted by the Engineer-in-charge.
- 7.5.5 The primer coat shall have finished film thickness of not less than 75 microns. Top coat shall have finished film thickness of not less than 150 microns.
- 7.5.6 All exterior surfaces of tube to be painted shall be well cleaned to remove dust, mill scale etc. to provide a finish to the approval of the Engineer-in-charge or his representatives.
- 7.5.7 All surfaces shall be cleaned and made free from oil, grease and deleterious materials and dried before applying primer coat or subsequent top coat.
- 7.5.8 Cleaned surfaces shall be painted with approved primer as soon as possible but no longer than three hours after cleaning.

- 7.5.9 All paints shall be applied by an approved painting method proposed by the material supplier and as approved by the Engineer-in-charge employing specialized labour. The contractor shall carefully supervise and be responsible for all stages of painting works, including surface preparation, protection against whether etc.
- 7.5.10 Coating shall not be carried when the level of humidity exceeds the limit above which it could have detrimental affect on the coating.
- 7.5.11 All paints shall be applied in as many coats and at such intervals as necessary to provide the specified minimum finished dry film thickness without runs, sage other blemishes and to ensure the proper curing, drying hardening of the coats.
- 7.5.12 Any painted surface damaged at any stages of the work shall be repeated as specified here in for the main coating work.
- 7.5.13 Tests to determine the adhesion will be carried out by the Engineer-in-charge by driving a sharp wood chisel laid almost flat on the coating through the coating and steel surface. A coating will be considered acceptably bonded, if considerable force is required for lift the film and if the portion of the coating remains in the valley of the sand blast pattern. Areas tested in this manner are to be made good by the contractor without charge.
- 7.5.14 The finished coating shall be generally smooth glossy.
- 7.5.15 Tubes shall not be removed from the coating area until 5 days after the final coating has been applied or authorized by the Engineer-in-charge.
- 7.5.16 Painting of the tubes shall be done only after the bottom RCC portion of the pile is concreted and it is hardened for a period of not less than 7 days.
- 7.6 **CRUSHER RUN SCREENING AND CONCRETE PLUG IN PILES**
- 7.6.1 After driving the piles to the required level the tubular portion of the pile has to be filled with concrete from (+) 1m level. For this purpose the portion up to this level has to be filled with crusher run screening with proper compaction.
- 7.7 **STEEL FABRICATION WORK**
- 7.7.1 The steel sections as specified shall be cut square accurately to correct lengths. The cut edges should be dressed to a neat and workmanship finish and be free from distortion where parts are to be in contact metal to metal. All materials shall be straight and if necessary, before being worked shall be straightened and/ or flattened and shall be free from twists.
- 7.7.2 The component parts shall be assembled and aligned in such a manner that they are neither twisted nor otherwise damaged and shall be so prepared that the specified camber, if any, is provided. Proper clamps, clips, jigs and other fasteners (bolts & welds) shall be placed in a balance pattern to avoid any distortion in the members and to ensure their correct positioning.
- 7.7.3 Welded connections shall be provided for joints except for the joints specially provided for erection purposes. For joints provided for erection purposes bolted connections shall be used.
- 7.7.4 All bolts shall be provided with washers of sufficient thickness. The threaded portion of each bolt shall project through the nuts at least one thread.

- 7.7.5 Welding shall be done in accordance with the specifications laid down in IS 816 and as per detailed working drawing or as directed by the Engineer in charge. Welding edges and the adjacent areas of the members (extending up to 20mm) shall be thoroughly cleaned of all oil, grease, scale and rust and made completely dry. Gaps between the members to be welded shall be kept free from all foreign matters. The welding procedure adopted and consumables used shall be got specifically approved by the Engineer-in-charge. Excessive convexity, shrinkage, cracks, under cutting, improperly fitted / misaligned parts, members distorted by the heat of welding etc. due to faulty welds shall be corrected- whole or portion- as directed by the Engineer-in-charge.
- 7.7.6 The steel sections as specified shall be straightened and cut square to correct lengths. The steel work shall be hoisted and placed in position carefully without any damage to itself and other structures and injury to workmen.
- 7.7.7 The suitability and capacity of all plants and equipments used for the work shall be to the complete satisfaction of the Engineer-in-charge.
- 7.7.8 Proper safety arrangements shall be provided for working and inspection at no extra cost wherever required.
- 7.7.9 If the fabrication is done outside the worksite premises the structural and fabrication should be subject to the inspection by the departmental officials. Suitable transport facilities shall be provided for the inspection staff.
- 7.7.10 The electrodes required for the welding work shall be got approved before use. The electrodes should be stored properly without exposing them to atmospheric action. Proper protection should be given for site fabrication. The welding must be carried out under a covered roof.
- 7.7.11 The contractor should possess plant and equipments, derricks. Lifting tackles, wire ropes, chain pulleys, jacks, welding sets etc. that may be required for fabrication and erection. The equipment being used shall be kept in good condition throughout.
- 7.7.12 Fabrication and erection of steel work shall be in accordance with the provision of IS 800.
- 7.7.13 All damages to steel works caused during the transit or otherwise at the time of fabrication or erection and after erection shall be made good at no extra cost.
- 7.7.14 All steel work shall be provided with one coat of iron primer Red Oxide/ Zinc Chromate paint. Before applying primer, all rust & scale shall be removed by scrapping or brushing with steel wire brushes. All dust & dirt shall be thoroughly wiped away from the surface. If the surface is wet, it shall be dried before priming coat is applied.
- 7.7.15 After completion of the required fabrication of members, the surface shall be well cleaned with wire brush and sandpapering as directed by the Engineer-incharge and one coat of Zinc Chromate primer shall be applied. Before application of the primer coat all the welded joints shall be got inspected and approved by the Engineer in charge. All painting work shall be done after the erection of steel members in position. Any damage to the painted surface during the course of

- erection shall be rectified as directed by the Engineer In charge after fixing the members in position. The fasteners like bolts, nuts etc. used during erection shall also be painted with a coat of primer and two coats of bituminastic paint
- 7.7.16 Sequence of erection of grillage/ angle members shall be so arranged that the structural stability is fully ensured.
- 7.7.17 Prior to the positioning of the members all laitance and loose materials shall be removed by wire brushing and chipping and bearing surfaces cleaned as directed by the Engineer in charge.
- 7.7.18 The rates given shall be for the finished items of work including fabricating, erecting and alignment with appropriate materials, all connections, welding, rectification wherever necessary, transporting and handling charges, all accessories, equipments, scaffolding, all lifts etc. including cost of all labour, and materials.
- 7.7.19 The finished work including erection shall be measured in Kilogram inclusive of the weight of posts, members, M.S plate stiffeners, M.S base plates, bolts, nuts, washers but no allowance shall be made for the welded material. The measurement for plates used on the work shall be made for the actual quantity used in work. The rate quoted per Kilogram shall be inclusive of cost of all materials & labour applying iron primer, erection in position, scaffolding, all transportation, lifts etc.

SIGNATURE OF TENDERER

COCHIN PORT AUTHORITY

**PROVIDING RCC CUM STEEL TUBULAR FENDER PILES AT BAGGAGE
JETTY, DIESEL PUMP JETTY, PILOT BOAT JETTY & EMBARKATION
JETTY**

UNDERTAKING REGARDING EPF AND ESI REGISTRATION

I/ We, M/s..... (Name & Address of the tenderer) solemnly affirm and undertake that I/ We do not have the required number of employees for taking registration under EPF Organisation and ESI Corporation. I/ We also undertake that I/ We take the full responsibility for all the consequences arising due to the above and indemnify CoPA officials for any actions taken in this regard

SIGNATURE OF TENDERER

ANNEXURE II

**PROFORMA OF UNDERTAKING THAT NO CHANGES HAVE BEEN MADE
IN THE TENDER DOCUMENT DOWNLOADED**

I/We.....
.....
.....do hereby confirm that no changes have been made in the
Tender document downloaded and submitted by us for the Tender No
.....

Yours faithfully,

Signature :

Name & Designation

ANNEXURE –III

FORMAT OF DECLARATION IN-LIEU OF EMD

(To be submitted on the Bidder’s Letter Head)

I/We(Insert Name and Address of Bidder) am/are submitting this declaration in lieu of Earnest Money Deposit for the Tender for
.....(Insert Title of the Tender) (Tender No.....), thereby fully accepting that I/We will be suspended and shall not be eligible to participate in the Tenders invited by Cochin Port, for a period of Two years from the date of such Suspension Orders, under the following circumstances:- a) If after the award of work, I/We fail to furnish the required Performance Security/ Security Deposit or sign the Contract, within the time limits specified in the Tender Document.

Signature of the Tenderer with seal

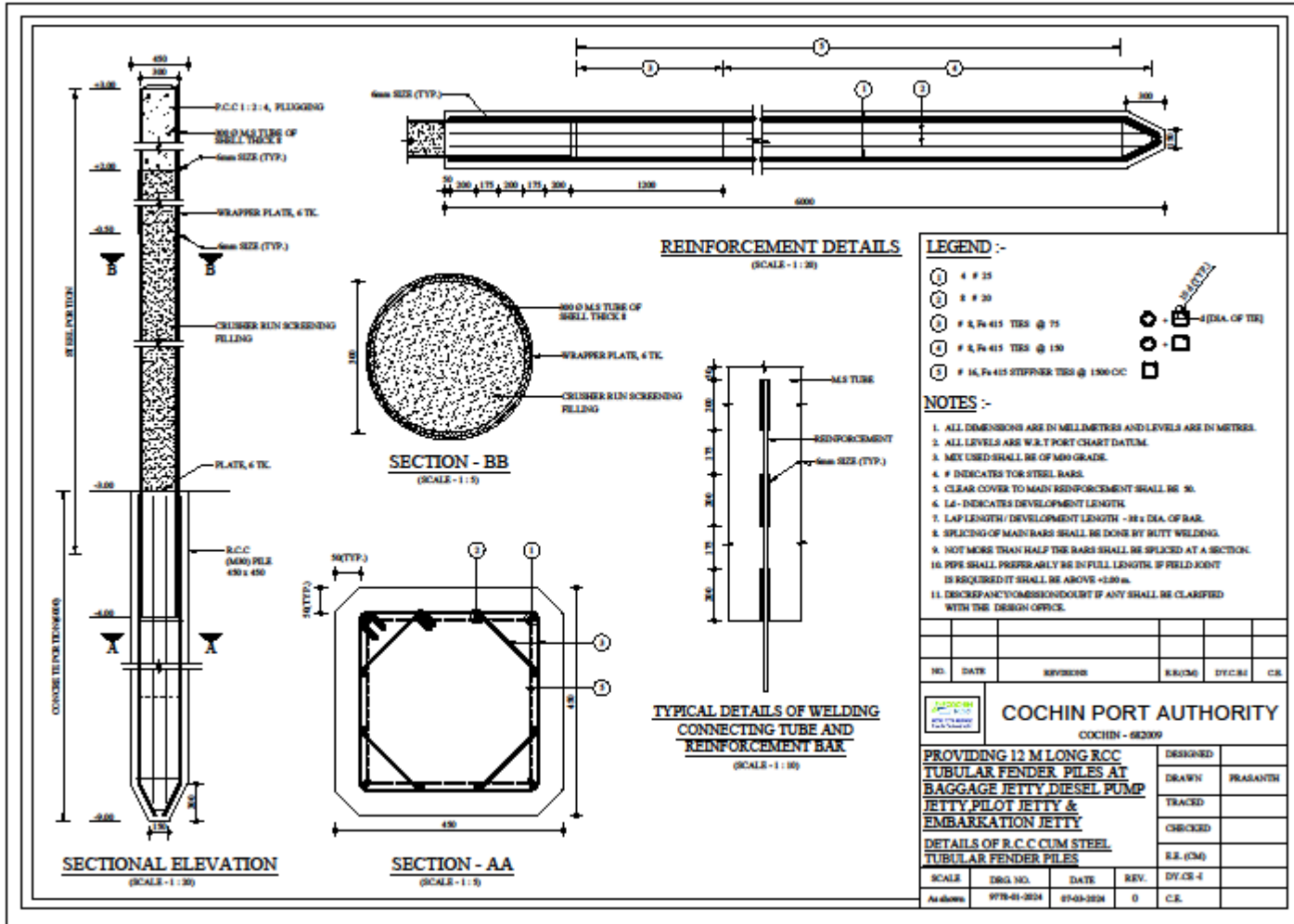

- LEGEND :-**
- ① # 25
 - ② # 30
 - ③ # 8, 7x45 TIES @ 75
 - ④ # 8, 7x45 TIES @ 150
 - ⑤ # 16, 7x45 STEPPER TIES @ 1500 CC
- - (DIA. OF TIE)

- NOTES :-**
1. ALL DIMENSIONS ARE IN MILLIMETRES AND LEVELS ARE IN METRES.
 2. ALL LEVELS ARE W.R.T PORT CHART DATUM.
 3. MIX USED SHALL BE OF M30 GRADE.
 4. # INDICATES FOR STEEL BARS.
 5. CLEAR COVER TO MAIN REINFORCEMENT SHALL BE 50.
 6. Ld - INDICATES DEVELOPMENT LENGTH.
 7. LAP LENGTH / DEVELOPMENT LENGTH - 35 x DIA. OF BAR.
 8. SPLICING OF MAIN BARS SHALL BE DONE BY BUTT WELDING.
 9. NOT MORE THAN HALF THE BARS SHALL BE SPLICED AT A SECTION.
 10. PILES SHALL PREFERABLY BE IN FULL LENGTH IF FIELD JOINT IS REQUIRED IT SHALL BE ABOVE -1.00 m.
 11. DISCREPANCY/OMISSION/DOBT IF ANY SHALL BE CLARIFIED WITH THE DESIGN OFFICE.

NO.	DATE	REVISION	BY/DM	BY/CM	BY/CE

 COCHIN PORT AUTHORITY COCHIN - 682009		DESIGNED	
		DRAWN	PRASANTH
PROVIDING 12 M LONG RCC TUBULAR FENDER PILES AT BAGGAGE JETTY DIESEL PUMP JETTY PILOT JETTY & EMBARKATION JETTY		TRACED	
DETAILS OF R.C.C CUM STEEL TUBULAR FENDER PILES		CHECKED	
SCALE	DWG. NO.	DATE	REV.
As shown	978-01-004	05-03-2024	0
			BY/CE-1
			C.E.