

# ANNUAL ENERGY AUDIT REPORT FOR THE YEAR 2022-23

Of



**COCHIN PORT AUTHORITY (CoPA)**  
Willingdon Island, Cochin

July 2023

*conducted by*



**Centre for Energy, Environment and Productivity**

**Accredited Energy Auditor – AEA 0133**

1039, 26<sup>th</sup> street, H Block, Ponni Colony

Anna Nagar, Chennai – 600 040

<http://tallkumar.wixsite.com/ceep> ☎ 044-26163483 📠 9444882553 ✉ [tallkumar@gmail.com](mailto:tallkumar@gmail.com)



## Centre for Energy, Environment and Productivity

Plot No 1039, 26th Street, 'H' Block,  
Ponni Colony, Anna Nagar,  
Chennai 600040  
☎ 044-26163483  
☎ 9444882553  
email: tallkumar@gmail.com

2<sup>nd</sup> August  
2023

**The Chief Mechanical Engineer,  
Cochin Port Authority,  
Willingdon Island,  
Cochin 682009.**

Sir,

**Sub: Energy Audit Report of the Cochin Port Authority (Designated Consumer Number: DIS0048KL)  
for the year 2022-23 -Submission -reg**

Ref:

1. 8/1/BEE/DISCOM/2021. Dated 06th October 2021 -Manner and Intervals for Conduct of Energy Audit (Accounting) in Electricity Distribution Companies) Regulations,2021 and subsequent amendments by the Bureau of Energy Efficiency
2. Contract No: GEMC-511687788965203 dated 4<sup>th</sup> July 2023

As per the reference cited above, please find enclosed herewith the Energy Audit Report of Cochin Port Authority (Designated Consumer Number: DIS0048KL), for favour of further action.

Yours faithfully

J Nagesh Kumar  
Accredited Energy Auditor

**Centre for Energy, Environment and Productivity  
Plot No. 1039, 26th Street, H-Block,  
Ponni Colony, Anna Nagar, Chennai - 600 040.  
PH : 044 2616 3483, 9444882553**

Enclosure: Energy audit report of Cochin Port Authority for the year 2022-23

## ACKNOWLEDGEMENT

On behalf of Centre for Energy, Environment and Productivity (CEEP), Chennai we place on record our sincere gratitude to the management of Cochin Port Authority (CoPA) for awarding us the task of carrying out Mandatory Energy audit, for the kind hospitality and support extended for the study of their services.

We wish to profusely thank Shri V. Thuraipandian, Chief Mechanical Engineer for his thought-provoking suggestions and sharing his pearls of wisdom with us while steering the conduct of the audit.

We are indebted to Shri Ajayakumar R.S., Executive Engineer (Elec) & Nodal officer and Smt Jayalakshmy S , Assistant Executive Engineer (Elec), for their extensive interactions and support rendered to the study.

We are extremely thankful to Shri Mathew Paul, Assistant Engineer (Elec), Shri Johny Alumparambil, Assistant Engineer (Electrical) and to all the other officers and staff who associated enthusiastically with us in organising and being a part of the audit process for successfully accomplishing the objectives of the audit.



J. Nagesh Kumar

Director, /AEA 0133

Centre for Energy, Environment and Productivity

1039,26<sup>th</sup> Street, H Block, Ponni Colony, Anna Nagar, Chennai-600040.

Email: tallkumar@gmail.com

**AUDIT TEAM**

<b>S.NO</b>	<b>Name of the officer</b>	<b>Qualification</b>	<b>Designation</b>
<b>1.</b>	<b>Dr. J. Nagesh Kumar</b>	<b>Ph.D.</b>	<b>Accredited Energy auditor Reg No: 0133</b>
<b>2</b>	<b>Shri Sunilkumar V K</b>	<b>B. Tech (Elec)</b>	<b>Sector expert (DISCOM) &amp; Certified Energy Auditor Reg No: EA 3642</b>
<b>3.</b>	<b>Shri Jagadish Chandran</b>	<b>B.E.</b>	<b>Electrical Auditor</b>
<b>4.</b>	<b>Shri K.G. Diwakar</b>	<b>M.E.</b>	<b>Certified Energy Auditor</b>

**TABLE OF CONTENTS**

1.	Executive summary	8
1.1	About DISCOM	8
1.2	Energy performance of the DISCOM	10
1.2.1	Performance summary of the CoPA for the FY 2022-23	10
1.2.2	Quarter wise Performance of the CoPA for the FY 2022-23	10
1.3.0	Category wise consumers and energy sales for the FY 2022-23	12
1.4	Infrastructure details	13
1.4.1	Voltage based Consumers and metering infrastructure	13
1.5	Feeder wise energy distribution in Willingdon Island	14
1.6	Details of Energy conservation measures adopted by the DISCOM	15
2..0	Background	17
2.1	Extend of regulation and the role of the BEE	17
2.2	Purpose of the audit and accounting report	22
2.3	Period of the energy audit and accounting	22
3.	Introduction of DISCOM	23
3.1	Name and address of the DISCOM(DC)	23
3.1.2	Name and details of the Energy Manager and authorised signatory (Nodal officer) the DC	23
3.1.3	Centralised Energy accounts and Audit Cell in CoPA (Team members)	23
3.2	Summary profile of the DISCOM with salient features	24
3.3.	Asset details	26
3.3.1	Infrastructure details	26
3.3.2	Voltage based consumers metering infrastructure and other assets	26
3.3.3	Distribution Transformer details	27
3.3.4.	Performance summary of the CoPA for the FY 2022-23	28
3.3.5	Energy input Particulars of CoPA for the FY 2022-23	28
3.3.6	Energy Sales Particulars of CoPA for the FY 2022-23	29
3.3.7	Category wise consumers for the FY 2022-23	30
3.4	Energy conservation measures already taken and proposed for future	32
4.	Energy flow analysis	34
4.1	Energy flow across 5 service levels	34
4.1.1	Energy Input Particulars of CoPA for the FY 2022-23	35
4.1.2	Energy Sales Particulars of CoPA for the FY 2022-23	36
4.2	Validation of metered data	37

## ANNUAL ENERGY AUDIT REPORT OF COCHIN PORT AUTHORITY FOR THE YEAR 2022-23

4.2.1	Physical verification of meters at Sub station	37
4.3	Verification and Validation of Input Energy	38
4.3.1	Verification of Purchase bill	38
4.3.1.1	Power purchase bill of Willingdon Island	38
4.3.1.2	Power purchase bill of Vallarpadam & Puthuvypin area	38
4.3.2.	Validation of Renewable Energy	39
4.3.3	Consolidated total of monthly statement for the FY 2022-23	40
4.3.4	Validation of Energy sales Particulars for the FY 2022-23	41
5	Losses and subsidy computation	42
5.1	Energy account of the previous years	42
5.2.	Input Energy, AT&C losses-aggregate, voltage wise, Category wise, Division wise etc	42
5.2.1	Energy accounts analysis and performance for the FY 2022-23	42
5.2.2	Quarter wise Energy input to the CoPA for the FY 2022-23	42
5.2.3	Quarter wise Energy Sales and Loss details for the FY 2022-23	44
5.2.4	Loss analysis of the two distribution areas under the CoPA for the FY 2022-23	46
5.2.5	Feeder wise Energy Distribution under the Willingdon Island for the FY 2022-23	47
5.3.	Subsidy computation and analysis (based on quarterly data)	48
5.3.1	Category wise consumption and revenue realisation for the FY 2022-23	47
5.3.2	Quarter wise and Category wise revenue realisation for the FY 2022-23	49
5.3.3.	Trend analysis and identifications of key exceptions	50
5.3.4.	Average billing rate under the CoPA for the FY 2022-23	50
6.	Energy audit findings	51
6.1	Review of capacity of the DISCOMs energy accounting and audit cell	51
6.2	Critical analysis by the Energy auditor	51
6.2.1	Status and Progress in compliance with the pre-requisites for Energy accounting	51

6.2.2	Status and Progress in compliance with the reporting requirements of the regulation	53
6.2.3.	Management analysis	55
6.3	Revised findings based on data validation and field verification	58
6.4	Inclusions and exclusions	59
6.5	Recommendations and best practises	59
7.	Conclusion and action plan	60
7.1	Summary of critical analysis by Energy Auditor	60
7.2	Summary of key findings	62
7.3	Recommendations and best practices for energy accounting and loss reduction	63
7.4. 1	Action plan for monitoring and reporting	65
7.4. 2	Action plan for automated energy accounting	66
8.	Annexure to be accompanied with the report	67
8.1.	Introduction of Verification team	68
8.2.	Minutes of the Meeting with the DISCOM team	69
8.3.	Check List prepared by auditing Firm.	71
8.4.	Brief Approach, Scope & Methodology for audit	72
8.5.	Infrastructure Details	76
8.5.1	Voltage based consumers and metering infrastructure	76
8.5.2	Detailed list of transformers	78
8.6.	Electrical Distribution System	79
8.6.1	Feeder wise load distribution under the Willingdon area	80
8.6.2	Energy performance of the previous year	80
8.6.3	Analysis of Performance of the Two Distribution areas under the CoPA for the FY 2022-23	81
8.7	Power Purchase Details	82
8.7.1	Power purchase details of the Willingdon Island	82
8.7.2	Power purchase details of the Vallarpadam area	83
8.8	Single line Diagram of the Transmission and Distribution system	84
8.8.1	SLD of the Willingdon Island	84
8.8.2	SLD of the Vallarpadam area	85
8.9	Category wise consumers and average billing rate	86
8.10	Category of service details	86

## ANNUAL ENERGY AUDIT REPORT OF COCHIN PORT AUTHORITY FOR THE YEAR 2022-23

8.11	List of documents verified with each parameter	87
8.12	Brief description of the Unit	88
8.13	List of Parameters arrived through calculation	88
8.14	Energy audit formats	89
8.15	Energy purchase bill Vallarpadam	99
8.16	Energy purchase bill Willingdon Island	100
8.17	Peak load measurement details of Transformers	101
8.18	Photos of functional feeder meters installed in Willingdon Island	102
8.19	Feeder meter readings downloaded from the AMI software	104
	List of Tables	106
	List of Figures	108



## 1. Executive Summary

### 1.1 About the DISCOM

Cochin Port Authority (CoPA) is a Body Corporate under the Major Port Authorities Act, 2021 (formerly Cochin Port Trust) .

CoPA is also a Deemed Electricity Distribution Licensee as per Electricity Act 2003 and a notified DC (DC No: DIS0048KL) under the PAT Cycle VII vide notification No: S.O.4552(E) dated 26<sup>th</sup> September 2022 by the Ministry of Power, GOI.

CoPA is purchasing electricity from M/s Kerala State Electricity Board Limited, a major distribution licensee and distributes to the consumers in Port area, under its jurisdictional power in Willingdon Island, Vallarpadam & Puthuvypin area. CoPA is availing 6.5MVA power at 110 KV system from KSEBL in Willingdon Island and 3 MVA power at 11 kV Voltage at Vallarpadam and distributing electricity to the consumers within the premises of the Port

Presently, CoPA has a 110kV/11kV Substation with 2Nos 10/12.5MVA power transformers and associated switchgears and control gears at Wellington Island and 11 kV receiving Station at Vallarpadam .11kV power is distributed to the consumers through 11kV UG Cables / dedicated 11 kV UG Cables and linked through Ring Main system for redundancy in supply /providing 24x7 days supply.LT feeding is by means of LT OH/ UG cable lines. At present there are 1256 consumers of which 36 are HT Consumers and 1220 are LT consumers. Consumer metering is 100% SMART meters for all category of consumers. However self-consumption and street light supply are metered through SMART meters/Electronic meters. Action has already been taken to purchase SMART meters for replacing the balance electronic meters with SMART meters. SMART Meters are with AMI features with prepaid facility. All the SMART Meters are connected to a centralised AMI software system through mobile network using GPRS . The billing and accounting are done using SAP System.

There are eleven 11 KV feeders emanating from 110/11 KV substation at Willingdon Island and four 11 kV feeders at Vallarpadam & Puthuvypin area. There are 30 nos of 11kV/415Volt and 11 kV/3.3 kV distribution transformers .CoPA has commissioned 100kWp and 150kWp grid connected solar plant . CoPA has also permitted Net metering facility for solar plants of four LT and HT Prosumers. Import/Export of energy from the solar plants are accounted through SMART meter. The energy inputs from the solar plants are also covered in the Energy audit.

## **Key Projects**

### **RDSS Project**

CoPA has obtained sanction for an amount of Rs 15.13 Crores for the modernisation and loss reduction projects under the Revamped Distribution Sector Scheme (RDSS) of Ministry of Power Govt of India. Additional infrastructure proposed through RDSS is the replacement of old cables, transformers and Ring main units, addition of 3 nos. 11 kV panels, completion of metering for 11 kV feeders, DTR metering and SCADA project. The above works will be commissioned during the financial year 2023-24 & 2024-25. All the infrastructures commissioned during the FY 2023-24 & 2024-25 will be covered under the scope of energy auditing / accounting.

### **Other Projects**

CoPA has proposed for enhancement of contract demand to 8 MVA at Vallarpadam for meeting the immediate power requirement of the consumers. So the total contract demand at Vallarpadam will be enhanced to 8 MVA in 11 kV system through multiple feeders by December 2023.

Further CoPA proposes to provide shore power supply to International Cruise Vessels calling at Cochin Port, as part of Maritime India Vision 2030(MIV 2030). The contract demand of 6 MVA power supply, CoPA propose to avail Green Energy through open Access, for this project.. The project is expected to be commissioned in FY 2024-25. The contract demand of CoPA at Willington Island will be enhanced to 12.5 MVA on commissioning of the shore power supply. CoPA proposes to implement 1.5MWp grid connected floating solar plant which is expected to be commissioned by March 2024.

## 1.2 Energy performance of the DISCOM

## 1.2.1 Performance summary of the CoPA for the FY 2022-23

S.NO	Energy input details	Units	Quantity
A	Energy purchased	MU	36.534
B	Net input energy (at DISCOM Periphery after adjusting the transmission losses and energy traded)	MU	36.534
C	Energy billed	MU	35.611
D	T& D Loss	MU	0.923
E	% T&D Loss	%	2.53
G	Amount of Energy billed	Rs (Crores)	38.29
H	Amount of collection	Rs (Crores)	38.29
H	Collection efficiency	%	100
I	% AT&C Loss	%	2.53

Table 1

## 1.2.2. Quarter wise performance of the CoPA for the FY 2022-23

S.NO	Energy input details	Units	QTR1	QTR2	QTR3	QTR 4
A	Energy purchased	MU	10.106	8.147	9.016	9.264
B	Net input energy (at DISCOM Periphery after adjusting the transmission losses and energy traded)	MU	10.106	8.147	9.016	9.264
C	Energy billed	MU	<b>9.790</b>	<b>7.953</b>	<b>8.820</b>	<b>9.048</b>
D	T& D Loss	MU	0.317	0.195	0.197	0.216
E	% T&D Loss	%	<b>3.13</b>	<b>2.39</b>	<b>2.16</b>	<b>2.33</b>
G	Amount of Energy billed	Rs (Crores)	10.50	8.45	9.45	9.88
H	Amount of collection	Rs (Crores)	10.50	8.45	9.45	9.88
H	Collection efficiency	%	100	100	100	100
I	% AT&C Loss	%	3.13	2.39	2.16	2.33

Table 2

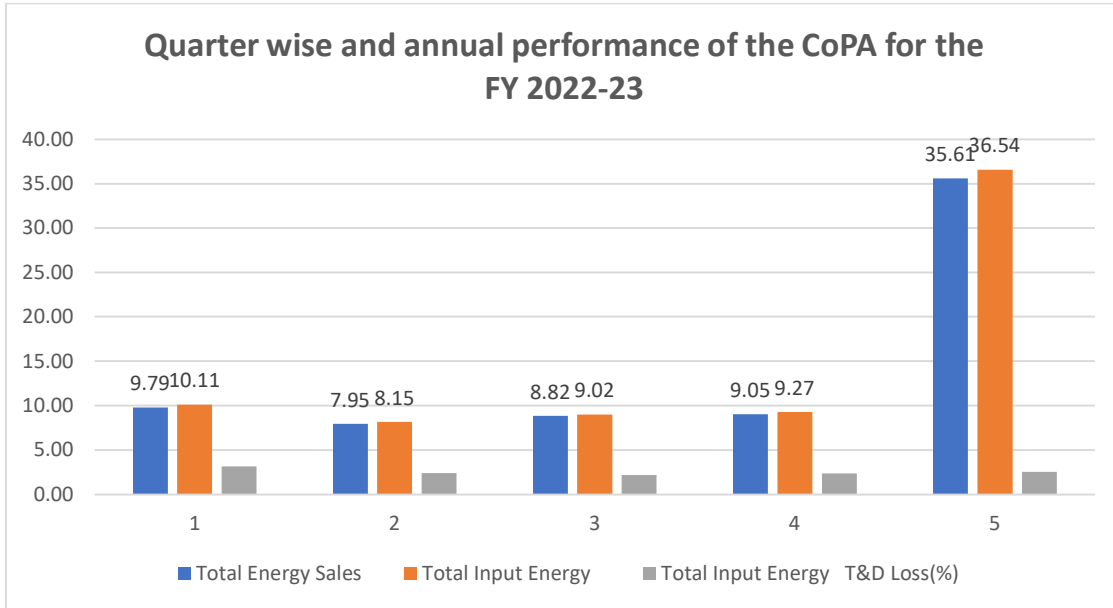

Net input Energy versus Total energy bill of CoPA for the year 2022-23

Figure-1

**1.2.5 Quarter wise T&D Loss performance for the FY 2022-23**

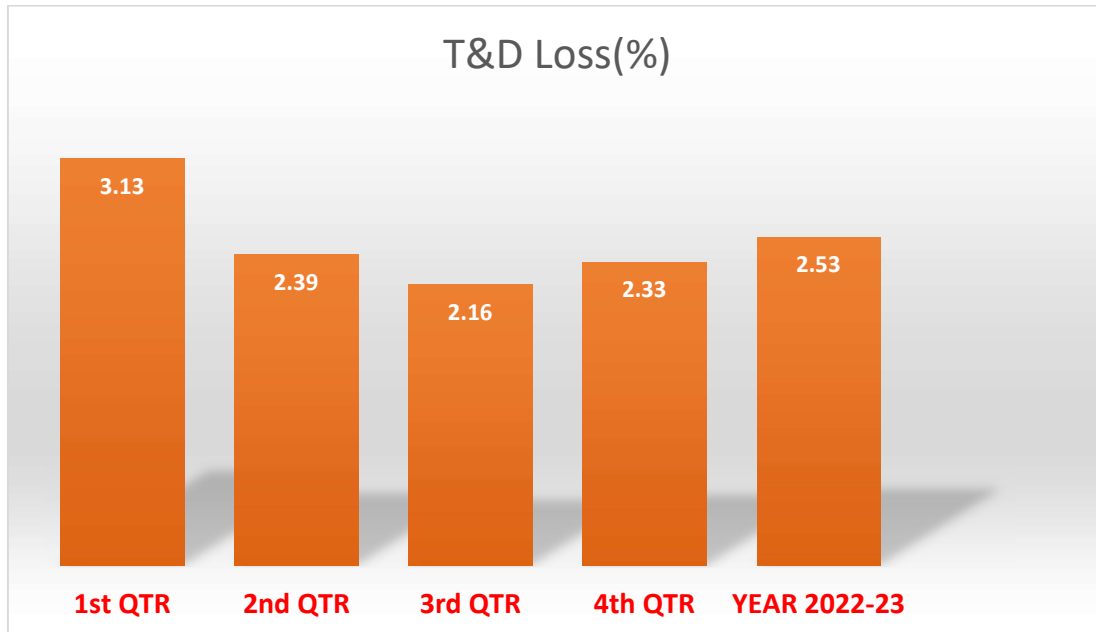

Fig -2

1.3 Category wise Consumers and Energy sales for the FY 2022-23

Period From 1st April 2022 to 31st March 2023								
Consumer profile			Energy parameters		Commercial Parameter			Average billing rate
Consumer category	Total Number of connections (Nos)	% of number of connections	Total energy	% of energy consumption	Billed Amount in Rs. Crore	Collected Amount in Rs. Crore	Collection Efficiency	
Residential	428	34%	0.926641	3%	0.602286	0.602286	100.00%	6.499671
Agricultural	0	0%	0	0%	0	0	0.00%	0
Commercial/Industrial-LT	582	46%	3.675433	10%	4.91468	4.91468	100.00%	13.3717
Commercial/Industrial-HT	29	2%	26.22357	74%	28.58328	28.58328	100.00%	10.89984
Others	217	17%	4.785379	13%	4.189846	4.189846	100.00%	8.755516
	<b>1256</b>	<b>100%</b>	<b>35.61103</b>	<b>100%</b>	<b>38.2901</b>	<b>38.2901</b>	<b>100.00%</b>	<b>10.75231</b>

Table 3

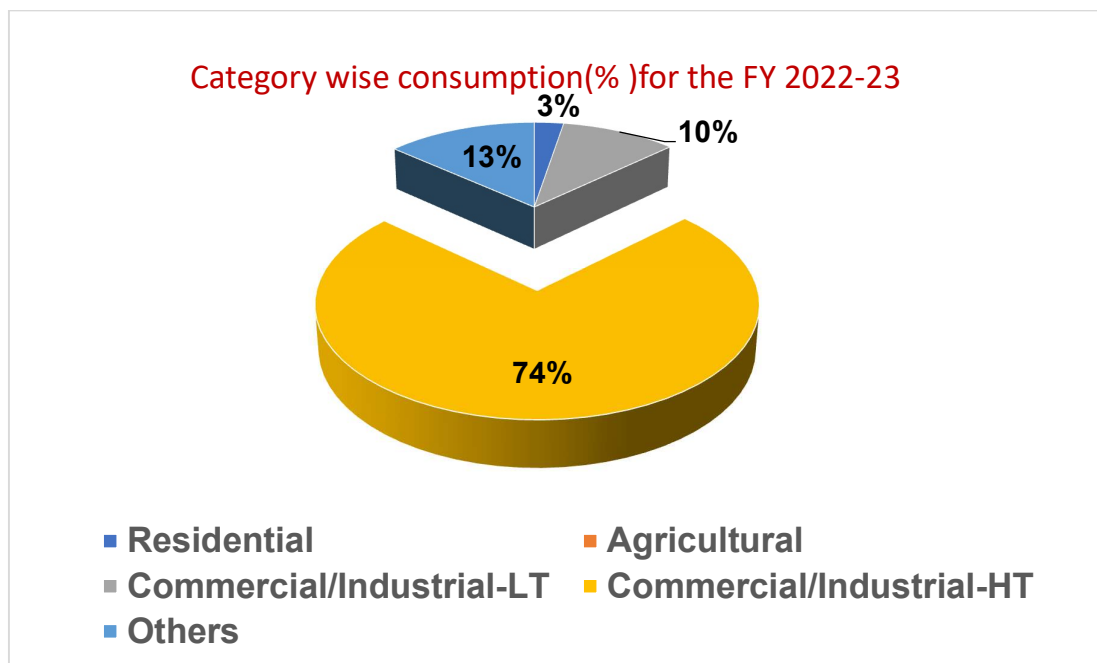

Fig 3

**1.4. Infrastructure details**

<b>Form-Details of Input Infrastructure</b>					
<b>1</b>	<b>Parameters</b>	<b>Total</b>	<b>Covered during in audit</b>	<b>Verified by Auditor in Sample Check</b>	<b>Remarks (Source of data)</b>
I	Number of circles	1	1		In CoPA there is no Circle or Division wise formations. However, the entire CoPA is treated as a Circle.
ii	Number of divisions	0			
iii	Number of sub-divisions	0			
iv	Number of feeders	15	15	11	List Provided by the DISCOM and AMI Software.
V	Number of DTs	30	30	0	List provided by the DISCOM
Vi	Number of consumers	1256	1256	126	Through SAP

Table 4

**1.4.1. Voltage based Consumers and metering infrastructure**

<b>2</b>	<b>Parameters</b>	<b>66kV and above</b>	<b>33kV</b>	<b>11/22kV</b>	<b>LT</b>
a i.	Number of conventional metered consumers	0	0	0	88
ii	Number of consumers with 'smart' meters	0	0	36	1132
iii	Number of consumers with 'smart prepaid' meters	0	0	0	0
iv	Number of consumers with 'AMR' meters	0	0	0	0
v	Number of consumers with 'non-smart prepaid' meters	0	0	0	0
vi	Number of unmetered consumers	0	0	0	0
vii	Number of total consumers	0	0	36	1220

b i	Number of conventionally metered Distribution Transformers	0	0	0	0
ii	Number of DTs with communicable meters	0	0	0	0
iii	Number of unmetered DTs	0	0	30	0
iv	Number of total Transformers	0	0	30	0
c. i.	Number of metered feeders	0	0	11	0
ii	Number of feeders with communicable meters	0	0	11	0
iii	Number of unmetered feeders	0	0	4	
iv	Number of total feeders	0	0	15	
d.	Line length (ckt km)	0	0	85	105
e.	Length of Aerial Bunched Cables (kM)	0	0	0	0
f.	Length of Underground Cables (kM)	0	0	85	

0

Table 5

### 1.5. FEEDER WISE ENERGY DISTRIBUTION IN WILLINGDON ISLAND

(Feeder wise loss could not be assessed due to the absence of functional meters in DTRs .

Load distribution through the Feeders from the Willingdon substation for the year 2022-23								
S.NO	Feeder Name	Feeder Metering Status (Metered/ unmetered/ AMI/AMR)	Status of Meter (Functional/Non-functional)	Feeder Type (Agri/ Industrial/Mixed)	CT/PT ratio	Import (MU)	Export (MU)	% load
1	MNC	AMI	Functional	Mixed	200/5	0.00	0.30	1.1
2	NTRO KV	AMI	Functional	Mixed	200/5	0.00	2.50	9.3
3	Q9 1	AMI	Functional	Mixed	200/5	0.00	6.69	24.8
4	Q92	AMI	Functional	mixed	200/5	0.00	4.40	16.3
5	MH2	AMI	Functional	Mixed	200/5	0.00	2.45	9.1
6	UTL	AMI	Functional	Mixed	200/5	0.00	2.59	9.6
7	Q93	AMI	Functional	Mixed	200/5	0.00	2.30	8.5
8	MH3	AMI	Functional	Mixed	200/5	0.00	0.00	0.0
9	STN TR	AMI	Functional	Mixed	200/5	0.00	0.08	0.3
10	PENNA	AMI	Functional	Commercial	200/5	0.00	4.80	17.8
11	NTRO A2	AMI	Functional	Mixed	200/5	0.00	0.91	3.4
				Total		0.00	27.01	100.0

Table 6

1.6. Details of Energy conservation measures implemented by the DISCOM

**FORM 3 (2022-23)**  
[Refer rule 3(2)]

DETAILS OF ENERGY EFFICIENCY IMPROVEMENT MEASURES IMPLEMENTED, INVESTMENT MADE AND SAVINGS  
IN ENERGY ACHIEVED AND PROGRESS MADE IN THE IMPLEMENTATION OF  
OTHER RECOMMENDATIONS

**A. Implemented**

Sl.No.	Description of energy efficiency improvements measure	Category	Investment (Lakh Rupees)	Verified savings (Lakh Rupees)	Verified energy savings per annum	Units	Fuel	Remarks
1	Replacement of SON lights with LED light	Lighting System	6.696	5.74	127583	kWh	Electricity	Electricity cost =Rs 4.5 per kWh
2	Replacement of old AC units with latest BEE rating units	Air Conditioning System	4.8	0.23	5103	kWh	Electricity	
3	Conventional tube lights with LED tubes lights.	Lighting System	0.66	0.64	14288.4			

**B. Under implementation**

Sl.No.	Description of energy efficiency improvements measure	Category	Investment (Rupees) estimated	Verified savings (Lakh Rupees) estimated	energy savings estimated	Units	Fuel	Status of implementation
1	Replacement of SON lights to LED lights for high mast etc.	Lighting System	29.3	1.84	40824	kWh	Electricity	Mar-24
2	Conversion of 3.3KV distribution system to 11 KV system.	Electrical System	27.08	2.02	44906.4	kWh	Electricity	Mar-24





ANNUAL ENERGY AUDIT REPORT OF COCHIN PORT AUTHORITY FOR THE YEAR 2022-23

FORM 3 (2022-23)

[Refer rule 3(2)]

DETAILS OF ENERGY EFFICIENCY IMPROVEMENT MEASURES IMPLEMENTED, INVESTMENT, INVESTMENT MADE AND SAVINGS IN ENERGY ACHIEVED AND PROGRESS MADE IN THE IMPLEMENTATION OF OTHER RECOMMENDATIONS

A. Implemented

Sl.No.	Description of energy efficiency improvements measure	Category	Investment (Lakh Rupees)	Verified savings (Lakh Rupees)	Verified energy savings per annum	Units	Fuel	Remarks
3	Replacement of AC units with latest 3-5 star rating AC units .	Air Conditioning System	14	3.67	81648	kWh	Electricity	Mar-24

Signature



Name of the energy manager: Mr. Sudalaikan  
 Regd. No.: CEM-300510  
 Email ID: [sskannanme@gmail.com](mailto:sskannanme@gmail.com)

Name of the company: Cochin Port Authority  
 Full address: Wellington Island, Ernakulam, Kerala-682009  
 Contact Name: Mrs.Jayalakshmy.S  
 Email address: [jayalakshmi@cochinport.gov.in](mailto:jayalakshmi@cochinport.gov.in)

Signature

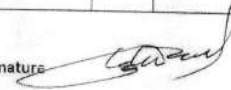

Name of the Accredited Energy Auditor: Mr.TN Agarwal  
 Certified Detail: AEA-0089

Seal



## **2. Back ground**

### **2.1 Extent of Regulations and role of BEE**

The Bureau of Energy Efficiency (BEE), through Ministry of Power, Government of India, notified the regulations viz. 'Bureau of Energy Efficiency (Manner and Intervals for Conduct of Energy Audit in Electricity Distribution Companies) Regulations, 2021' vide Notification No.18/1/BEE/DISCOM/2021 dated 6th October 2021, and subsequent amendment issued thereof on 28th Oct. 2022. The extent of regulations specifies the following key aspects related to energy accounting and audit for electricity distribution companies.

- I. Intervals of time for conduct of periodic energy accounting and annual energy audit and report submission thereof.
- II. Pre-requisites for annual energy audit and periodic energy accounting.
- III. Reporting requirements for annual energy audit and periodic energy accounting.
- IV. Manner of annual energy audit and periodic energy accounting.
- V. Prioritization and preparation of action plan and
- VI. Structure of annual energy audit report

These regulations have been issued under the ambit of Energy Conservation Act, 2001, with an overall objective to reduce inefficiencies and losses in distribution sector thereby ensuring financial and economic viability of DISCOMs. These regulations shall apply to all electricity distribution companies specified as designated consumer. They shall come into force on the date of their publication in the Official Gazette.

**1. Intervals of time for conduct of annual energy audit.** - (1) Every electricity distribution company shall conduct an annual energy audit for every financial year and submit the annual energy audit report to the Bureau and respective State Designated Agency which will be made available on the website of the electricity distribution company within a period of four months from the expiry of the relevant financial year. Provided that, on the commencement of these regulations, the first annual energy audit of every electricity distribution company shall be conducted within six months from the date of such commencement, by taking into account the energy accounting of electricity distribution company for the financial year immediately preceding the date of the commencement of these regulations.

**2. Intervals of time for conduct of periodic energy accounting. -**

(1) Every electricity distribution company shall —

(a) ensure that all feeder wise, circle wise and division wise periodic energy accounting shall be conducted by the energy manager of the electricity distribution company for each quarter of the financial year; and

(b) submit the periodic energy accounting report to the Bureau and respective State Designated Agency and also made available on the website of electricity distribution company within forty-five days from the date of the periodic energy accounting.

(2) After the commencement of these regulations, every electricity distribution company shall, notwithstanding anything in sub-regulation (1),

(a) Conduct its first periodic energy accounting, for the last quarter of the financial year immediately preceding the date of such commencement; and

(b) Conduct its subsequent periodic energy accounting for each quarter of the financial year for a period of two financial years from the date of such commencement,

**5. Pre-requisites for annual energy audit and periodic energy accounting** — Save as otherwise provided, every electricity distribution company shall undertake all actions as may be required for the annual energy audit and periodic energy accounting before the start of the relevant financial year, including the following actions, namely: —

(a) the identification and mapping of all of the electrical network assets;

(b) the identification and mapping of high tension and low-tension consumers;

(c) the development and implementation of information technology enabled energy accounting and audit system, including associated software;

(d) the electricity distribution company shall ensure the installation of functional meters for all consumers, transformers and feeders: Provided that meter installation may be done in a phased manner within a period of three financial years from the date of the commencement of these regulations in accordance with the trajectory set out in the First Schedule;

(e) All distribution transformers (other than high voltage distribution system upto 25kVA and other distribution system below 25 kVA) shall be metered with communicable meters. And

existing noncommunicable distribution transformer meters shall be replaced with communicable meters and integrated with advanced metering infrastructure;

(f) The electricity distribution company shall establish an information technology enabled system to create energy accounting reports without any manual interference: Provided that such system may be established—

(i) within a period of three years from the date of the commencement of these regulations in case of urban and priority area consumers; and

(ii) within five years from the date of the commencement of these regulations in case of rural consumers;

(g) the electricity distribution company shall create a centralized energy accounting and audit cell comprising of— (i) a nodal officer, an energy manager and an information technology manager, having professional experience of not less than five years;

(ii) a financial manager having professional experience of not less than five years; (h) any other requisite that Bureau may direct for energy audit and accounting purpose.

#### **6. Reporting requirements for annual energy audit and periodic energy accounting**

- (1) Every electricity distribution company shall designate a nodal officer, who shall be a full-time employee of the electricity distribution company in the rank of the Chief Engineer or above, for the purpose of reporting of the annual energy audit and periodic energy accounting and communicate the same to the Bureau.
- (2) Every electricity distribution company shall ensure that the energy accounting data is generated from a metering system or till such time the metering system is not in place, by an agreed method of assumption as may be prescribed by the State Commission.
- (3) Metering of distribution transformers at High Voltage Distribution System up to 25KVA can be done on cluster meter installed by each electricity distribution company.
- (4) The energy accounting and audit system and software shall be developed to create monthly, quarterly and yearly energy accounting reports.
- (5) Every electricity distribution company shall provide the details of the information technology system in place as specified in clause (f) of regulation 5 that ensures minimal manual intervention in creating the energy accounting reports and any manual intervention of any nature, in respect of the period specified therein, shall be clearly indicated in the periodic energy accounting report.

**7. Manner of annual energy audit and periodic energy accounting. -**

(1) Every annual energy audit and periodic energy accounting under these regulations shall be conducted in the following manner, namely: —

(a) verification of existing pattern of energy distribution across periphery of electricity distribution company; and

(b) verification of accounted energy flow submitted by electricity distribution company at all applicable voltage levels of the distribution network, —

(i) energy flow between transmission and 66kV/33kV/11kV incoming distribution feeders; (ii) energy flow between 66kV/33kV outgoing and 11kV/6.6kV incoming feeders;

(iii) energy flow between 11 kV/6.6kV feeders and distribution transformers, or high voltage distribution system;

(iv) energy flow between distribution transformer, or high voltage distribution system to end consumer, including ring main system;

(v) energy flow between Feeder to end-consumer; and

(vi) energy flow between 66/33/11 kV directly to consumer.

(2) The accredited energy auditor, in consultation with the nodal officer of the electricity distribution company shall, —

(a) develop a scope of work for the conduct of energy audit required under these regulations;

(b) agree on best practice procedures on accounting of energy distributed across the network; and

(c) collect data on energy received, and distributed, covered within the scope of energy audit.

(3) The accredited energy auditor shall— (a) verify the accuracy of the data collected in consultation with the nodal officer of the electricity distribution companies as per standard practice to assess the validity of the data collected; and (b) analyse and process the data with respect to—

(i) consistency of data monitoring compared to the collected data;

(ii) recommendations to facilitate energy accounting and improve energy efficiency; and

(iii) with respect to the purpose of energy accounting in reducing losses for the electricity distribution company

**TRAJECTORY FOR METER INSTALLATION****Timeline for metering—**

- (i) 100% Communicable Feeder Metering integrated with AMI, by 31<sup>st</sup> December 2022 along-with replacement of existing non-communicable feeder meters.
- (ii) All Distribution Transformers (other than HVDS DT upto 25kVA and other DTs below 25 kVA) shall be metered with communicable meters. Communicable DT Metering for the following areas / consumers to be completed by December 2023 and in balance areas by December 2025:
- All Electricity Divisions of 500 AMRUT cities, with AT&C Losses > 15%
  - All Union Territories (for areas with technical difficulty, non-communicable meters may be installed);
  - All Industrial and Commercial consumers;
  - All Government offices at Block level and above;
  - Other high loss areas i.e. rural areas with losses more than 25% and urban areas with losses more than 15%. Further, existing non-communicable Distribution Transformer meters to be replaced with communicable meters integrated with AMI, within the timelines applicable to the respective areas.
- (iii) Prepaid Smart Consumer Metering to be completed for all directly connected meters and AMR in case of other meters, by December 2023 in the following areas:
- All Electricity Divisions of 500 AMRUT cities, with AT&C Losses > 15%;
  - All Union Territories (for areas with technical difficulty, prepaid meters to be installed);
  - All Industrial and Commercial consumers;
  - All Government offices at Block level and above;
  - Other high loss areas i.e. rural areas with losses more than 25% and urban areas with losses more than 15%. The balance areas and consumers may be taken up in a phased manner subsequently. However, Distribution Companies can additionally cover any other areas as well as agricultural consumers, at their option by December 2023. Further, in rural / hilly areas with connectivity or communication issues, wherein installation of smart meters may not be feasible, prepaid meters may be opted for
- (iv) Consumer Metering:
- 98% by FY 2022-23
  - 99% by FY 2023-24

Meter	2022-23	2023-24	2024-25
Feeder Metering	98.5%	99.5%	99.5%
DT Metering	90%	95%	98%
Consumer Metering	93%	96%	98%

**Table 7**

## **2.2 Purpose of audit and accounting Report**

Bureau of Energy Efficiency (BEE) through Ministry of Power, Government of India issued regulations for the Conduct of Mandatory Annual Energy Audit and Periodic Energy Accounting in DISCOMs vide regulation No:

As per the regulation, all Electricity Distribution Companies are mandated to conduct annual energy audit and periodic energy accounting on quarterly basis.

Owing to the impact of energy auditing on the entire distribution and retail supply business and absence of an existing framework with dedicated focus on the same, it was imperative to develop a set of comprehensive guidelines that all Distribution utilities across India can follow and adhere to.

Accordingly, Regulations on Manner and Intervals for Conduct of Energy Audit and Accounting in Electricity Distribution Companies has been framed. Energy Accounting means accounting of all energy inflows at various voltage levels in the distribution periphery of the network, including renewable energy generation and open access consumers, and energy consumption by the end consumers. Energy accounting and a consequent annual energy audit would help to identify areas of high loss and pilferage, and thereafter focus efforts to take corrective action.

These Regulations for Energy audit in Electricity Distribution Companies provides broad framework for conduct of Annual Energy Audit though and Quarterly Periodic Energy Accounting with necessary Pre-requisites and reporting requirements to be met.

## **2.3 Period of the Energy Audit**

The period of the audit is for the year 2022-23. This is the third annual energy audit in the CoPA, as per the BEE Regulations.

### 3. Introduction of DISCOM

#### 3.1 Name and address of the DISCOM (DC)

##### **Cochin Port Authority (CoPA)**

P.O. Willingdon Island

Ernakulam -682009,

Kerala.

#### 3.1 .1 Name and details of Energy Manager and authorized signatory of DISCOM

1	<b>Energy Manager</b>	2	<b>Nodal officer</b>
	<p>Mrs. Jayalakshmy. S Asst. Exe. Engineer (Ele)- EM Cochin Port Authority Willingdon Island, Kochi, Kerala 682009 Whether CEA/CEM- Nil <b>Phone No: 9496450704</b> <b>Email: jayalakshmi@cochinport.gov.in</b></p>		<p>Mr. Ajayakumar R.S, Executive Engineer (Elec) Cochin Port Authority Willingdon Island, Kochi, Kerala 682009 Phone: 9444610664</p>

**Table 8 A**

#### 3.1.2 Centralised Energy accounts and Audit Cell in CoPA (Team members)

S.No	Name of the Officer	Official designation	Role
1.	Shri Ajayakumar R.S	Executive Engineer (Elec)	Nodal officer
2.	Smt Jayalakshmy S	Assistant Executive Engineer (Ele)	Energy Manager
3.	Sri Vinod C	Senior Deputy Director EDP	I.T Manager
4	Smt Surya Madhu	Senior Accounts officer	Finance Manager

**Table 8 B**



### **3.2 Summary profile of the DISCOM with salient features**

#### **About the DISCOM**

Cochin Port Authority (CoPA) is a Body Corporate under the Major Port Authorities Act, 2021 (formerly Cochin Port Trust).

CoPA is also a Deemed Electricity Distribution Licensee as per Electricity Act 2003 and a notified DC (DC No: **DIS0048KL**) under the PAT Cycle VII vide notification No: S.O.4552(E) dated 26<sup>th</sup> September 2022 by the Ministry of Power, GOI.

CoPA is purchasing electricity from M/s Kerala State Electricity Board Limited, a major distribution licensee and distributes to the consumers in Port area, under its jurisdictional power in Willingdon Island, Vallarpadam & Puthuvypin area. CoPA is availing 6.5MVA power at 110 KV system from KSEBL in Willingdon Island and 3 MVA power at 11 kV Voltage at Vallarpadam and distributing electricity to the consumers within the premises of the Port

Presently, CoPA has a 110kV/11kV Substation with 2Nos 10/12.5MVA power transformers and associated switchgears and control gears at Wellington Island and 11 kV receiving Station at Vallarpadam .11kV power is distributed to the consumers through 11kV UG Cables / dedicated 11 kV UG Cables and linked through Ring Main system for redundancy in supply /providing 24x7 days supply.LT feeding is by means of LT OH/ UG cable lines. At present there are 1256 consumers of which 36 are HT Consumers and 1220 are LT consumers. Consumer metering is 100% SMART meters for all category of consumers. However self-consumption and street light supply are metered through SMART meters/Electronic meters. Action has already been taken to purchase SMART meters to replacing the electronic meters with SMART meters. SMART Meters are with AMI features with prepaid facility. All the SMART Meters are connected to a centralised AMI software system through mobile network using GPRS. The billing and accounting are done using SAP System.

There are eleven 11 KV feeders emanating from 110/11 KV substation at Willingdon Island and four 11 kV feeders at Vallarpadam & Puthuvypin area. There are 30 numbers of 11kV/415Volt and 11 kV/3.3 kV distribution transformers .CoPA has commissioned 100kWp and 150kWp grid connected solar plant . CoPA has also permitted Net metering facility for solar plants of 4 LT and HT Prosumers. Import/Export of energy from the solar plants are accounted through SMART meter. The energy inputs from the solar plants are also covered in the Energy audit.

## **Key Projects**

### **RDSS Project**

CoPA has obtained sanction for an amount of Rs 15.13 Crores for the modernisation and loss reduction projects under the Revamped Distribution Sector Scheme (RDSS) of Ministry of Power Govt of India. Additional infrastructure proposed through RDSS is the replacement of old cables, transformers and Ring main units, addition of 3 nos. 11 kV panels, completion of metering for 11 kV feeders, DTR metering and SCADA project. The above works will be commissioned during the financial year 2023-24 & 2024-25. All the infrastructures commissioned during the FY 2023-24 & 2024-25 will be covered under the scope of energy auditing / accounting.

### **Other Projects**

CoPA has proposed for enhancement of contract demand to 8 MVA at Vallarpadam for meeting the immediate power requirement of the consumers. So the total contract demand at Vallarpadam will be enhanced to 8 MVA in 11 kV system through multiple feeders by December 2023.

Further CoPA proposes to provide shore power supply to International Cruise Vessels calling at Cochin Port., as part of Maritime India Vision 2030(MIV 2030). The contract demand of 6 MVA power supply, CoPA propose to avail Green Energy through open Access, for this project. The project is expected to be commissioned in FY 2024-25. The contract demand of CoPA at Willington Island will be enhanced to 12.5 MVA on commissioning of the shore power supply. CoPA proposes to implement 1.5MWp grid connected floating solar plant which is expected to be commissioned by March 2024.

### 3.3 Asset details

#### 3.3.1 Infrastructure details

Form-Details of Input Infrastructure					
S.NO	Parameters	Total	Covered during in audit	Verified by Auditor in Sample Check	Remarks (Source of data)
I	Number of circles	1	1	1	In CoPA there is no Circle or Division wise formations. However, the entire CoPA is treated as a Circle.
II	Number of divisions	0			
III	Number of sub-divisions	0			
IV	Number of feeders	15	15	11	List provided by the DISCOM and AMI Software .
V	Number of DTs	30	30	0	List provided by the DISCOM.
VI	Number of consumers	1256	1256	126	SAP

Table 9

#### 3.3.2 Voltage wise consumers metering infrastructures and other assets.

S.NO	Parameters	66kV and above	33kV	11/22kV	LT
a i	Number of conventional metered consumers	0	0	0	88
ii	Number of consumers with 'smart' meters	0	0	36	1132
iii	Number of consumers with 'smart prepaid' meters	0	0	0	0
iv	Number of consumers with 'AMR' meters	0	0	0	0
v	Number of consumers with 'non-smart prepaid' meters	0	0	0	0
vi	Number of unmetered consumers	0	0	0	0
vii	Number of total consumers	0	0	36	1220
b i	Number of conventionally metered Distribution Transformers	0	0	0	0

ii	Number of DTs with communicable meters	0	0	0	0
iii	Number of unmetered DTs	0	0	30	0
iv	Number of total Transformers	0	0	30	
c i	Number of metered feeders	0	0	11	0
ii	Number of feeders with communicable meters	0	0	11	0
iii	Number of unmetered feeders	0	0	4	
iv	Number of total feeders	0	0	15	
d.	Line length (ckt km)	0		85	105
e.	Length of Aerial Bunched Cables (kM)	0	0	0	0
f.	Length of Underground Cables (kM)	0	0	85	

Table 10

### 3.3.3 Distribution Transformer details

S.NO	Asset details	Unit	Quantity
1.	110kV/11 kV 12.5 MVA Power Transformers	No	2
2	POWER FACTOR CAPACITOR 1000 kVAR	NO	2
2.	11 kV Feeders	No	15
3.	Distribution Transformer 11kV/415 V 1250 kVA	No	2
4	Distribution Transformer 11kV/415 V 1000 kVA	No	1
5	Distribution Transformer 11kV/415 V 800 kVA	No	3
6	Distribution Transformer 11kV/415 V 630 kVA	No	9
7	Distribution Transformer 11kV/415 V 500 kVA	No	8
8	Distribution Transformer 11kV/415 V 315 kVA	No	3
9	Distribution Transformer 3.3 kV/433 V 300 kVA	No	1
11	Distribution Transformer 3.3 kV/415 V 250 kVA	No	3

Table 11

**3.3.4 Performance summary of the CoPA for the FY 2022-23**

S.NO	Energy input details	Units	Quantity
A	Energy purchased	MU	36.534
B	Net input energy (at DISCOM Periphery after adjusting the transmission losses and energy traded)	MU	36.534
C	Energy billed	MU	35.611
D	T& D Loss	MU	0.923
E	% T&D Loss	%	2.53
G	Amount of Energy billed	Rs (Crores)	38.29
H	Amount of collection	Rs (Crores)	38.29
H	Collection efficiency	%	100
I	% AT&C Loss	%	2.53

**Table 12****3.3.5 Energy Input Particulars of the CoPA for the FY 2022-23**

Voltage level	Particulars	MU
66kV and above	Long-Term Conventional	27.054
	Medium Conventional	0.000
	Short Term Conventional	0.000
	Banking	0.000
	Long-Term Renewable energy	0.000
	Medium and Short-Term RE	0.000
	Captive, open access input	0.000
	Sale of surplus power	0.000
	Quantum of inter-state transmission loss	0.000
	<b>Power procured from inter-state sources</b>	27.054
	<b>Power at state transmission boundary</b>	27.054
33kV	Long-Term Conventional	0.000
	Medium Conventional	0.000
	Short Term Conventional	0.000
	Banking	0.000
	Long-Term Renewable energy	0.000
	Medium and Short-Term RE	0.000
	Captive, open access input	0.000
	Sale of surplus power	0.000
	Quantum of intra-state transmission loss	0.000
	<b>Power procured from intra-state sources</b>	0.000
	<b>Input in DISCOM wires network</b>	0.000
33 kV	Renewable Energy Procurement	0.000

	Small capacity conventional/ biomass/ hydro plants Procurement	0.000
	Captive, open access input	0.000
11 kV	Renewable Energy Procurement	0.000
	Small capacity conventional/ biomass/ hydro plants Procurement	0.000
	Sales Migration Input	9.144
LT	Renewable Energy Procurement	0.336
	Sales Migration Input	0.000
	<b>Energy Embedded within DISCOM wires network</b>	0.000
	<b>Total Energy Available/ Input</b>	36.534

Table 13

## 3.3.6 Energy sales Particulars of the CoPA for the FY 2022-23

4	Voltage level	Energy Sales Particulars	MU
i	LT Level	DISCOM' consumers	7.402
		Demand from open access, captive	0.000
		Embedded generation used at LT level	0.000
		Sale at LT level	7.402
		Quantum of LT level losses	**
		Energy Input at LT level	7.402
ii	11 kV Level	DISCOM' consumers	28.209
		Demand from open access, captive	0.000
		Embedded generation at 11 kV level used	0.000
		<b>Sales at 11 kV level</b>	28.209
		Quantum of Losses at 11 kV	**
		Energy input at 11 kV level	36.198
iii	33 kV Level	DISCOM' consumers	0.000
		Demand from open access, captive	0.000
		Embedded generation at 33 kV or below level	0.000
		<b>Sales at 33 kV level</b>	0.000
		Quantum of Losses at 33 kV	0.000
		Energy input at 33kV Level	0.000
iv	> 33 kV	DISCOM' consumers	0.000
		Demand from open access, captive	0.000
		Cross border sale of energy	0.000
		Sale to other DISCOMs	0.000
		Banking	0.000
		Energy input at > 33kV Level	0.000

	<b>Sales at 66kV and above (EHV)</b>	0.000
	<b>Total Energy Sales</b>	<b>35.611</b>
	<b>Total Energy input</b>	<b>36.534</b>
<b>T &amp; D LOSS</b>	<b>MU</b>	<b>0.923</b>
	<b>%</b>	<b>2.53</b>

\*\*HT and LT Level losses could not be assessed due to the absence of Feeder meters and DTR meters

Table 14

## 3.3.7 Category wise consumers

Period From 1st April 2022 to 31st March 2023								
Consumer profile			Energy parameters		Commercial Parameter			Average billing rate
Consumer category	Total Number of connections (Nos)	% of number of connections	Total energy	% of energy consumption	Billed Amount in Rs. Crore	Collected Amount in Rs. Crore	Collection Efficiency	
Residential	428	34%	0.926641	3%	0.602286	0.602286	100.00%	6.499671
Agricultural	0	0%	0	0%	0	0	0.00%	0
Commercial/Industrial-LT	582	46%	3.675433	10%	4.91468	4.91468	100.00%	13.3717
Commercial/Industrial-HT	29	2%	26.22357	74%	28.58328	28.58328	100.00%	10.89984
Others	217	17%	4.785379	13%	4.189846	4.189846	100.00%	8.755516
	<b>1256</b>	<b>100%</b>	<b>35.61103</b>	<b>100%</b>	<b>38.2901</b>	<b>38.2901</b>	<b>100.00%</b>	<b>10.75231</b>

Table 15

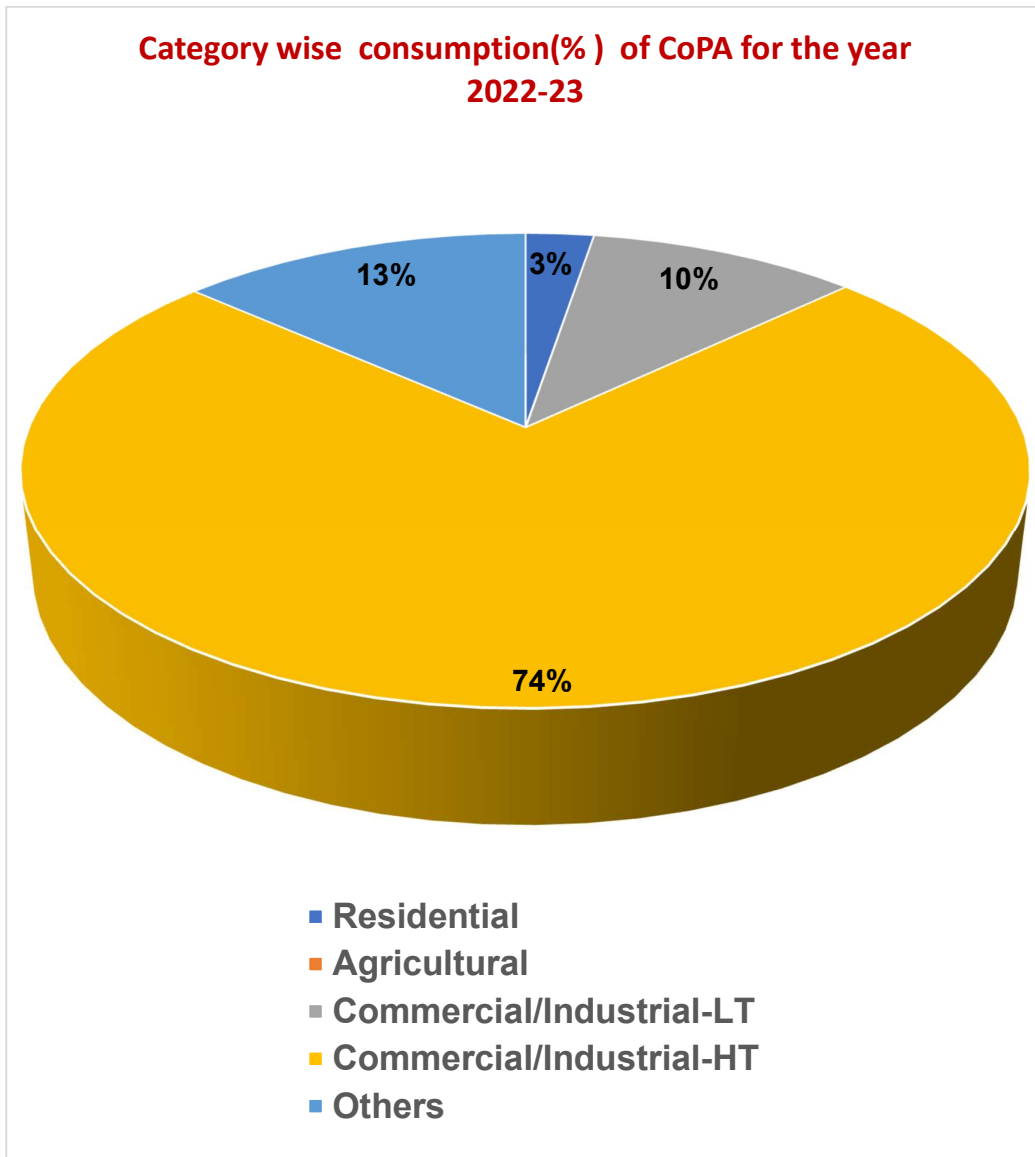

Fig 4



3.4 Details of the Energy Conservation measures implemented under the DISCOM

FORM 3 (2022-23)  
[Refer rule 3(2)]  
DETAILS OF ENERGY EFFICIENCY IMPROVEMENT MEASURES IMPLEMENTED, INVESTMENT, INVESTMENT MADE AND SAVINGS  
IN ENERGY ACHIEVED AND PROGRESS MADE IN THE IMPLEMENTATION OF  
OTHER RECOMMENDATIONS

A. Implemented

Sl.No.	Description of energy efficiency improvements measure	Category	Investment (Lakh Rupees)	Verified savings (Lakh Rupees)	Verified energy savings per annum	Units	Fuel	Remarks
1	Replacement of SON lights with LED light	Lighting System	6.696	5.74	127583	kWh	Electricity	Electricity cost =Rs 4.5 per kWh
2	Replacement of old AC units with latest BEE rating units	Air Conditioning System	4.8	0.23	5103	kWh	Electricity	
3	Conventional tube lights with LED tubes lights.	Lighting System	0.66	0.64	14288.4			

B. Under implementation

Sl.No.	Description of energy efficiency improvements measure	Category	Investment (Rupees) estimated	Verified savings (Lakh Rupees) estimated	energy savings estimated	Units	Fuel	Status of implementation
1	Replacement of SON lights to LED lights for high mast etc.	Lighting System	29.3	1.84	40824	kWh	Electricity	Mar-24
2	Conversion of 3.3KV distribution system to 11 KV system.	Electrical System	27.08	2.02	44906.4	kWh	Electricity	Mar-24

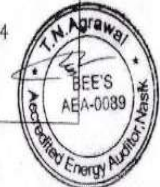

ANNUAL ENERGY AUDIT REPORT OF COCHIN PORT AUTHORITY FOR THE YEAR 2022-23

FORM 3 (2022-23)

[Refer rule 3(2)]

DETAILS OF ENERGY EFFICIENCY IMPROVEMENT MEASURES IMPLEMENTED, INVESTMENT, INVESTMENT MADE AND SAVINGS IN ENERGY ACHIEVED AND PROGRESS MADE IN THE IMPLEMENTATION OF OTHER RECOMMENDATIONS

A. Implemented

Sl.No.	Description of energy efficiency improvements measure	Category	Investment (Lakh Rupees)	Verified savings (Lakh Rupees)	Verified energy savings per annum	Units	Fuel	Remarks
3	Replacement of AC units with latest 3-5 star rating AC units .	Air Conditioning System	14	3.67	81648	kWh	Electricity	Mar-24

Signature

Name of the energy manager: Mr. Sudalaikan  
 Regd. No.: CEM-300510  
 Email ID: [sskannanme@gmail.com](mailto:sskannanme@gmail.com)

Signature

Name of the Accredited Energy Auditor: Mr.TN Agarwal  
 Certified Detail: AEA-0089

Name of the company: Cochin Port Authority  
 Full address: Wellington Island, Ernakulam, Kerala-682009  
 Contact Name: Mrs.Jayalakshmy.S  
 Email address: [jayalakshmi@cochinport.gov.in](mailto:jayalakshmi@cochinport.gov.in)

Seal

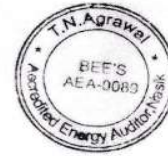

## 4. Energy flow analysis

### 4.1. Energy flow across 5 service levels

In CoPA presently the Energy consumption is only in 11 KV and LT Levels. Power is received in Willingdon Island at 110 kV and stepdown to 11 kV level. Renewable injection is at LT levels. Due to non-installation of meters in all the 11 kV feeders and DTRs, losses cannot be segregated at feeder level and DTR level. However, the energy is distributed by the CoPA in two separate geographical areas without any border sharing. Hence presently loss can be assessed only at the DISCOM level and at the area level in the two distribution areas. The power input at the two areas is indicated in the following diagram.

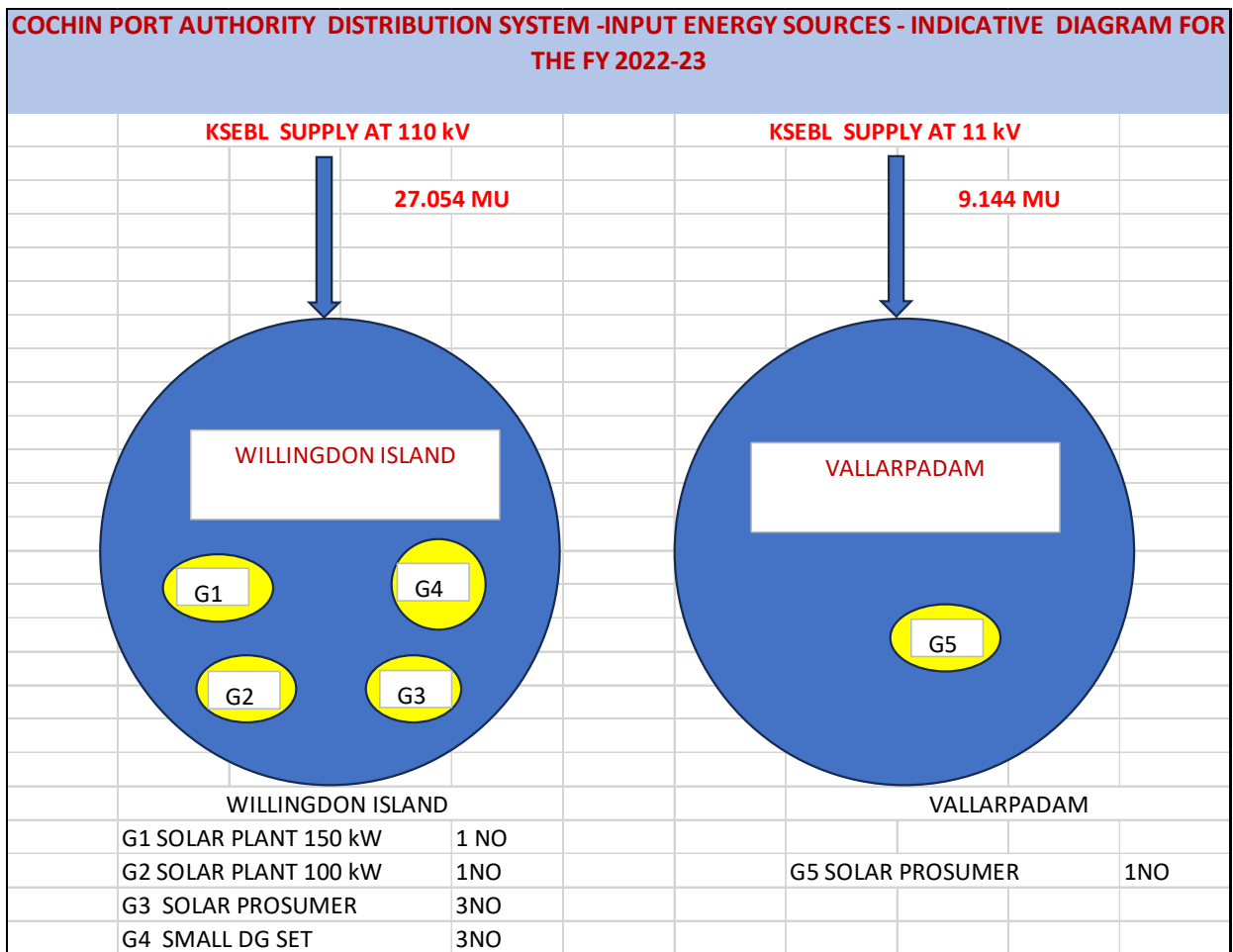

Fig 5

## 4.1.1 ENERGY INPUT PARTICULARS OF CoPA for the FY 2022-23

Voltage level	Particulars	MU
66kV and above	Long-Term Conventional	27.054
	Medium Conventional	0.000
	Short Term Conventional	0.000
	Banking	0.000
	Long-Term Renewable energy	0.000
	Medium and Short-Term RE	0.000
	Captive, open access input	0.000
	Sale of surplus power	0.000
	Quantum of inter-state transmission loss	0.000
	<b>Power procured from inter-state sources</b>	27.054
	<b>Power at state transmission boundary</b>	27.054
33kV	Long-Term Conventional	0.000
	Medium Conventional	0.000
	Short Term Conventional	0.000
	Banking	0.000
	Long-Term Renewable energy	0.000
	Medium and Short-Term RE	0.000
	Captive, open access input	0.000
	Sale of surplus power	0.000
	Quantum of intra-state transmission loss	0.000
	<b>Power procured from intra-state sources</b>	0.000
	<b>Input in DISCOM wires network</b>	0.000
33 kV	Renewable Energy Procurement	0.000
	Small capacity conventional/ biomass/ hydro plants Procurement	0.000
	Captive, open access input	0.000
11 kV	Renewable Energy Procurement	0.000
	Small capacity conventional/ biomass/ hydro plants Procurement	0.000
	Sales Migration Input	9.144
LT	Renewable Energy Procurement	0.336
	Sales Migration Input	0.000
	<b>Energy Embedded within DISCOM wires network</b>	0.000
	<b>Total Energy Available/ Input</b>	36.534

Table 16

**4.1.2 Energy sales Particulars for the FY 2022-23**

<b>4</b>	<b>Voltage level</b>	<b>Energy Sales Particulars</b>	<b>MU</b>
i	LT Level	DISCOM' consumers	7.402
		Demand from open access, captive	0.000
		Embedded generation used at LT level	0.000
		Sale at LT level	7.402
		Quantum of LT level losses	**
		Energy Input at LT level	**
ii	11 kV Level	DISCOM' consumers	28.209
		Demand from open access, captive	0.000
		Embedded generation at 11 kV level used	0.000
		<b>Sales at 11 kV level</b>	28.209
		Quantum of Losses at 11 kV	**
		Energy input at 11 kV level	36.198
iii	33 kV Level	DISCOM' consumers	0.000
		Demand from open access, captive	0.000
		Embedded generation at 33 kV or below level	0.000
		<b>Sales at 33 kV level</b>	0.000
		Quantum of Losses at 33 kV	0.000
		Energy input at 33kV Level	0.000
iv	> 33 kV	DISCOM' consumers	0.000
		Demand from open access, captive	0.000
		Cross border sale of energy	0.000
		Sale to other DISCOMs	0.000
		Banking	0.000
		Energy input at > 33kV Level	27.054
		<b>Sales at 66kV and above (EHV)</b>	0.000
		<b>Total Energy Sales</b>	<b>35.611</b>
		<b>Total Energy input</b>	<b>36.534</b>
<b>T &amp; D LOSS</b>		<b>MU</b>	<b>0.923</b>
		<b>%</b>	<b>2.53</b>

\*\*HT and LT category level losses could not be assessed due to the absence of Feeder meters and DTR meters

**Table 17**

## 4.2 Validation of metered data

Verification and Validation of Energy input and 11 kV Feeders at Substations						
S.NO	Energy Particulars	Metering infrastructure	Number of meters	Functional status	Sample checked	Remarks
	1 ENERGY INPUT (KSEBL)					
a	Willingdon Island	110kV Input supply	*1	0		*Only supplier (KSEBL) meter in the CoPA premises. There is no communicable meter on the CoPA side.
						Energy input validated by verifying the Purchase bills
b	Vallarpadam	11 Kv Input supply	*1	0		*Only supplier (KSEBL) meter in the CoPA premises. There is no communicable meter on the CoPA side.
						Energy input validated by verifying the Purchase bills
	2 Renewable Energy					
a	150 kW	1	1	1	1	1 Verified the monthly data provided by the DISCOM taken from AMI Software
b	100 kW	1	1	1	1	1 Do-
b	Solar prosumers	4	4	4	4	4 Verified the monthly data provided by the DISCOM taken from AMI Software
c	Small DG Sets	3	3	3	3	3 Do
	3 11 kV Feeders					
	Willingdon Island	11	11	11	11	11 Validated both by site verification and by verifying the Software Data.
	Vallarpadam	4	4	0	4	4 Meters not functional

Table 18

### 4.2.1 Physical verification of meters at Substation

#### Willingdon Island

S.NO	FEEDER NAME	Meter S.NO	Meter reading	Date of reading
1	Q91	GP4409885	551281.3	13/07/23
2	Q92	GP4409882	394589.7	13/07/23
3	UTL	GP4409883	0315231	13/07/23
4	NTRO A2	GP4409899	40429.4	13/07/23

Table 19

### 4.3. Verification and Validation of input energy

#### 4.3.1. Verification of Purchase bill

##### 4.3.1.1 Power purchase details of the Willingdon Island

Consumer No: 1355410002636							
Contract demand :6500							
	MD Charges			Energy charges			Total charges
MONTH	Maximum demand	Rate /KV A	MD Charges	Consumption	Unit rate	Energy charges	Total charges
May-22	6588	340	2239920	2604600	6.10	15888060	18152440
Jun-22	6578	340	2236520	2650350	6.10	16167135	18416915
Jul-22	4875	380	1852500	2130600	6.25	13316250	14684673
Aug-22	4875	380	1852500	2002950	6.25	12518437.5	14057977
Sep-22	4875	380	1852500	1973850	6.25	12335312.5	13880649
Oct-22	4875	380	1852500	2043300	6.25	12770625	14303859
Nov-22	4958	380	1884040	2134200	6.25	13338750	14890412
Dec-22	5040	380	1915200	2239350	6.25	13995937.5	15581412
Jan-23	4982	380	1893160	2301900	6.25	14386875	15920363
Feb-23	5772	380	219336	2242200	6.25	14013750	15856766
Mar-23	6024	380	2289120	2165250	6.25	13532812.5	15483612
Apr-23	6376	380	2422880	2565150	6.25	16032187.5	18054277
Total				27053700			

**Table 20**

##### 4.3.1.2 Power Purchase details of the Vallarpadam & Puthuvypin area

Consumer No: 1355xxxxx3590							
Contract demand 3000							
	MD Charges			Energy charges			
MONTH	Maximum demand	Rate KVA	MD Charges	Consumption	Unit rate	Energy charges	Total charges
May-22	2250	340	765000	1141850	6.10	6965285.0	7730285
Jun-22	2250	340	765000	816000	6.10	4977600.0	5970503
Jul-22	2250	380	855000	691700	6.25	4323125.0	7809011
Aug-22	2250	380	855000	695200	6.25	43451562.5	5264775
Sep-22	2250	380	855000	647640	6.25	4047750.0	4939848
Oct-22	2250	380	855000	703480	6.25	4396750.0	5163815
Nov-22	2250	380	855000	851320	6.25	5320750.0	6182250
Dec-22	2250	380	855000	698840	6.25	4367750.0	5429009
Jan-23	2250	380	855000	703120	6.25	4394500.0	5323994
Feb-23	2250	380	855000	648400	6.25	4052500.0	4991646
Mar-23	2250	380	855000	664000	6.25	4150000	5084665
Apr-23	2250	380	855000	882760	6.25	5517250	6432106
Total				9144310			

**Table 21**

## 4.3.2 Validation of Renewable energy

## Month wise statements generated from Software

		Energy input to Distribution Grid				
		(1) Purchase	(2) Generation			(3) Total: (1) + (2)
			Solar Port	Solar Prosumers	DG Sets Port	
May 22	Willingdon island	26,04,600	23,970	1,112	835	26,30,517
	Vallarpadam	1141850	0	0	0	11,41,850
	<b>Total</b>	<b>37,46,450</b>	<b>23,970</b>	<b>1,112</b>	<b>835</b>	<b>37,72,367</b>
June-22	Willingdon island	26,50,350	20,140	692	27	26,71,209
	Vallarpadam	816000	0	0	0	8,16,000
	<b>Total</b>	<b>34,66,350</b>	<b>20,140</b>	<b>692</b>	<b>27</b>	<b>34,87,209</b>
July-22	Willingdon island	21,30,600	21,970	1,763	559	21,54,892
	Vallarpadam	691700	0	20	0	6,91,720
	<b>Total</b>	<b>28,22,300</b>	<b>21,970</b>	<b>1,783</b>	<b>559</b>	<b>28,46,612</b>
Aug 22	Willingdon island	20,02,950	21,400	1,944	12	20,26,306
	Vallarpadam	695200	0	320	0	6,95,520
	<b>Total</b>	<b>26,98,150</b>	<b>21,400</b>	<b>2,264</b>	<b>12</b>	<b>27,21,826</b>
Sep 22	Willingdon island	19,73,850	22,330	2,561	164	19,98,905
	Vallarpadam	647640	0	184	0	6,47,824
	<b>Total</b>	<b>26,21,490</b>	<b>22,330</b>	<b>2,745</b>	<b>164</b>	<b>26,46,729</b>
Oct -22	Willingdon island	20,43,300	28,230	3,126	283	20,74,939
	Vallarpadam	703480	0	296	0	7,03,776
	<b>Total</b>	<b>27,46,780</b>	<b>28,230</b>	<b>3,422</b>	<b>283</b>	<b>27,78,715</b>
Nov-22	Willingdon island	21,34,200	28,290	2,913	40	21,65,443
	Vallarpadam	851320	0	96	0	8,51,416
	<b>Total</b>	<b>29,85,520</b>	<b>28,290</b>	<b>3,009</b>	<b>40</b>	<b>30,16,859</b>
Dec-22	Willingdon island	22,39,350	24,750	2,638	392	22,67,130
	Vallarpadam	698840	0	360	0	6,99,200
	<b>Total</b>	<b>29,38,190</b>	<b>24,750</b>	<b>2,998</b>	<b>392</b>	<b>29,66,330</b>
Jan-22	Willingdon island	23,01,900	24,870	2,556	233	23,29,559
	Vallarpadam	703120	0	232	0	7,03,352
	<b>Total</b>	<b>30,05,020</b>	<b>24,870</b>	<b>2,788</b>	<b>233</b>	<b>30,32,911</b>
Feb-23	Willingdon island	22,42,200	28,750	3,643	381	22,74,974
	Vallarpadam	648400	0	560	0	6,48,960
	<b>Total</b>	<b>28,90,600</b>	<b>28,750</b>	<b>4,203</b>	<b>381</b>	<b>29,23,934</b>
Mar-23	Willingdon island	21,65,250	25,190	3,475	1,685	21,95,600
	Vallarpadam	664000	0	8	0	6,64,008
	<b>Total</b>	<b>28,29,250</b>	<b>25,190</b>	<b>3,483</b>	<b>1,685</b>	<b>28,59,608</b>
Apr-23	Willingdon island	25,65,150	28,070	2,873	1,642	25,97,735
	Vallarpadam	882760	0	439	0	8,83,199
	<b>Total</b>	<b>34,47,910</b>	<b>28,070</b>	<b>3,312</b>	<b>1,642</b>	<b>34,80,934</b>

Table 22



**4.3.3 Consolidated total of monthly statements for the FY 2022-23**

<b>Consolidated total for the FY 2022-23 as per the monthly statement</b>					
	Solar Plant (250 kW)	solar Prosumers	Total	Total (MU)	Total Renewable energy reported in the input statement (MU)
Renewable energy	2,97,960	31,811	3,29,771.00	0.330	0.336024
Energy through DG Sets	6,253			* 0.006253	0
				0.336024	

**\*The meagre quantity of the DG energy in the LT System is added along with the renewable energy source due to nil provision to add the same in the LT system.**

**Table 23**

## 4.3.4. Validation of Energy Sale Particulars

<b>Monthwise Energy Loss statement -From Division Loss statement</b>					
Energy units in kWh					
<b>2022-23 Q1</b>		<b>TOTAL</b>			
<b>Cons.</b>	<b>Billing</b>	<b>Purchase</b>	<b>Billed</b>	<b>Loss</b>	<b>% Loss</b>
<b>Apr</b>	May	36,68,562	35,51,412	1,17,150	3.193
<b>May</b>	Jun	35,62,270	34,82,031	80,239	2.252
<b>Jun</b>	Jul	28,75,356	27,56,132	1,19,224	4.146
<b>TOTAL</b>		<b>1,01,06,188</b>	<b>97,89,575</b>	<b>3,16,613</b>	<b>3.133</b>
<b>2022-23 Q2</b>		<b>TOTAL</b>			
<b>Cons.</b>	<b>Billing</b>	<b>Purchase</b>	<b>Billed</b>	<b>Loss</b>	<b>% Loss</b>
<b>Jul</b>	Aug	27,21,826	26,23,785	98,041	3.602
<b>Aug</b>	Sep	26,46,729	26,30,494	16,235	0.613
<b>Sep</b>	Oct	27,78,715	26,98,262	80,453	2.895
<b>TOTAL</b>		<b>81,47,270</b>	<b>79,52,541</b>	<b>1,94,729</b>	<b>2.390</b>
<b>2022-23 Q3</b>		<b>TOTAL</b>			
<b>Cons.</b>	<b>Billing</b>	<b>Purchase</b>	<b>Billed</b>	<b>Loss</b>	<b>% Loss</b>
<b>Oct</b>	Nov	30,16,859	29,51,870	64,989	2.154
<b>Nov</b>	Dec	29,66,330	28,97,272	69,058	2.328
<b>Dec</b>	Jan	30,32,911	29,71,509	61,402	2.025
<b>TOTAL</b>		<b>90,16,100</b>	<b>88,20,651</b>	<b>1,95,449</b>	<b>2.168</b>
<b>2022-23 Q4</b>		<b>TOTAL</b>			
<b>Cons.</b>	<b>Billing</b>	<b>Purchase</b>	<b>Billed</b>	<b>Loss</b>	<b>% Loss</b>
<b>Jan</b>	Feb	29,23,934	28,66,307	57,627	1.971
<b>Feb</b>	Mar	28,59,608	27,96,114	63,494	2.220
<b>Mar</b>	Apr	34,80,934	33,85,838	95,096	2.732
<b>TOTAL</b>		<b>92,64,476</b>	<b>90,48,259</b>	<b>2,16,217</b>	<b>2.334</b>
<b>Total for the year 2022-23</b>		<b>3,65,34,034</b>	<b>3,56,11,026</b>	<b>9,23,008</b>	<b>2.526</b>

Table 24

## 5. Losses and Subsidy computation

### 5.1. Energy accounts of the Previous Years

S.NO	Energy input details	Units	2020-21	2021-22
A	Energy purchased	MU	35.581	36.719
B	Net input energy (at DISCOM Periphery after adjusting the transmission losses and energy traded)	MU	35.581	36.719
C	Energy billed	MU	34.219	35.405
D	T& D Loss	MU	1.362	1.313
E	% T&D Loss	%	3.82	3.577

Table 25

### 5.2 Input Energy, AT&C losses-aggregate, Voltage wise ,category wise and Area wise

#### 5.2.1 Energy account and performance for the FY 2022-23

S.NO	Energy input details	Units	Quantity
A	Energy purchased	MU	36.534
B	Net input energy (at DISCOM Periphery after adjusting the transmission losses and energy traded)	MU	36.534
C	Energy billed	MU	35.611
D	T& D Loss	MU	0.923
E	% T&D Loss	%	2.53
G	Amount of Energy billed	Rs (Crores)	38.29.
H	Amount of collection	Rs (Crores)	38.29
H	Collection efficiency	%	100
I	% AT&C Loss	%	2.53

Table 26

#### 5.2.2 Quarter wise energy input to the CoPA for the FY 2022-23

Voltage level	Energy input particulars	QTR 1	QTR 2	QTR 3	QTR 4	Year
		(MU)	(MU)	(MU)	(MU)	2022-23 (MU)
66kV and above	Long-Term Conventional	7.386	6.020	6.675	6.973	<b>27.054</b>
	Medium Conventional	0.000	0.000	0.000	0.000	0.000
	Short Term Conventional	0.000	0.000	0.000	0.000	0.000
	Banking	0.000	0.000	0.000	0.000	0.000
	Long-Term Renewable energy	0.000	0.000	0.000	0.000	0.000

	Medium and Short-Term RE	0.000	0.000	0.000	0.000	0.000
	Captive, open access input	0.000	0.000	0.000	0.000	0.000
	Sale of surplus power	0.000	0.000	0.000	0.000	0.000
	Quantum of inter-state transmission loss	0.000	0.000	0.000	0.000	0.000
	<b>Power procured from inter-state sources</b>	7.386	6.020	6.675	6.973	0.000
	<b>Power at state transmission boundary</b>	7.386	6.020	6.675	6.973	27.054
33kV	Long-Term Conventional	0.000	0.000	0.000	0.000	0.000
	Medium Conventional	0.000	0.000	0.000	0.000	0.000
	Short Term Conventional	0.000	0.000	0.000	0.000	0.000
	Banking	0.000	0.000	0.000	0.000	0.000
	Long-Term Renewable energy	0.000	0.000	0.000	0.000	0.000
	Medium and Short-Term RE	0.000	0.000	0.000	0.000	0.000
	Captive, open access input	0.000	0.000	0.000	0.000	0.000
	Sale of surplus power	0.000	0.000	0.000	0.000	0.000
	Quantum of intra-state transmission loss	0.000	0.000	0.000	0.000	0.000
		<b>Power procured from intra-state sources</b>	0.000	0.000	0.000	0.000
	<b>Input in DISCOM wires network</b>	7.386	6.020	6.675	6.973	27.054
33 kV	Renewable Energy Procurement	0.000	0.000	0.000	0.000	0.000
	Small capacity conventional/ biomass/ hydro plants Procurement	0.000	0.000	0.000	0.000	0.000
	Captive, open access input	0.000	0.000	0.000	0.000	0.000
11 Kv	Renewable Energy Procurement	0.000	0.000	0.000	0.000	0.000
	Small capacity conventional/ biomass/ hydro plants Procurement	0.000	0.000	0.000	0.000	0.000
	Sales Migration Input	2.650	2.046	2.253	2.195	9.144
LT	Renewable Energy Procurement	0.071	0.081	0.087	0.097	0.336
	Sales Migration Input	0.000	0.000	0.000	0.000	0.000
	Energy Embedded within DISCOM wires network	0.00	0.00	0.00	0.00	0.00
	<b>Total Energy Available/ Input</b>	10.106	8.147	9.016	9.264	36.534

Table 27

## 5.2.3. Quarter wise energy sales and loss details for the FY 2022-23

		YEAR	QTR 1	QTR 2	QTR 3	QTR 4	2022-23
4	Voltage level	Energy Sales Particulars	MU	MU	MU	MU	MU
i	LT Level	DISCOM' consumers	1.913	1.728	1.876	1.885	7.402
		Demand from open access, captive	0.000	0.000	0.000	0.000	0.000
		Embedded generation used at LT level	0.000	0.000	0.000	0.000	0.000
		Sale at LT level	1.913	1.728	1.857	1.885	7.402
		Quantum of LT level losses	**	**	**	**	**
		Energy Input at LT level	**	**	**	**	**
ii	11 kV Level	DISCOM' consumers	7.876	6.224	6.945	7.164	28.209
		Demand from open access, captive	0.000	0.000	0.000	0.000	0.000
		Embedded generation at 11 kV level used	0.000	0.000	0.000	0.000	0.000
		<b>Sales at 11 kV level</b>	7.876	6.224	6.945	7.164	28.209
		Quantum of Losses at 11 kV	**	**	**	**	**
		Energy input at 11 kV level	10.035	8.066	8.929	9.168	36.198
iii	33 kV Level	DISCOM' consumers	0.000	0.000	0.000	0.000	0.000
		Demand from open access, captive	0.000	0.000	0.000	0.000	0.000
		Embedded generation at 33 kV or below level	0.000	0.000	0.000	0.000	0.000
		<b>Sales at 33 kV level</b>	0.000	0.000	0.000	0.000	0.000
		Quantum of Losses at 33 kV	0.000	0.000	0.000	0.000	0.000
		Energy input at 33kV Level	0.000	0.000	0.000	0.000	0.000
iv	> 33 kV	DISCOM' consumers					0.000
		Demand from open access, captive	0.000	0.000	0.000	0.000	0.000
		Cross border sale of energy	0.000	0.000	0.000	0.000	0.000
		Sale to other DISCOMs	0.000	0.000	0.000	0.000	0.000
		Banking	0.000	0.000	0.000	0.000	0.000
		Energy input at > 33kV Level	7.386	6.020	6.675	6.973	27.054
		<b>Sales at 66kV and above (EHV)</b>	0.000	0.000	0.000	0.000	0.000
<b>Total Energy sales</b>			<b>9.790</b>	<b>7.953</b>	<b>8.820</b>	<b>9.048</b>	35.611
<b>Total Energy input /requirement</b>			<b>10.106</b>	<b>8.147</b>	<b>9.016</b>	<b>9.264</b>	36.534
T&D Loss (%)			<b>3.133</b>	<b>2.390</b>	<b>2.16</b>	<b>2.334</b>	<b>2.525</b>

\*\*HT and LT Level losses could not be assessed due to the absence of Feeder meters and DTR meters

Table 28

Fig 5

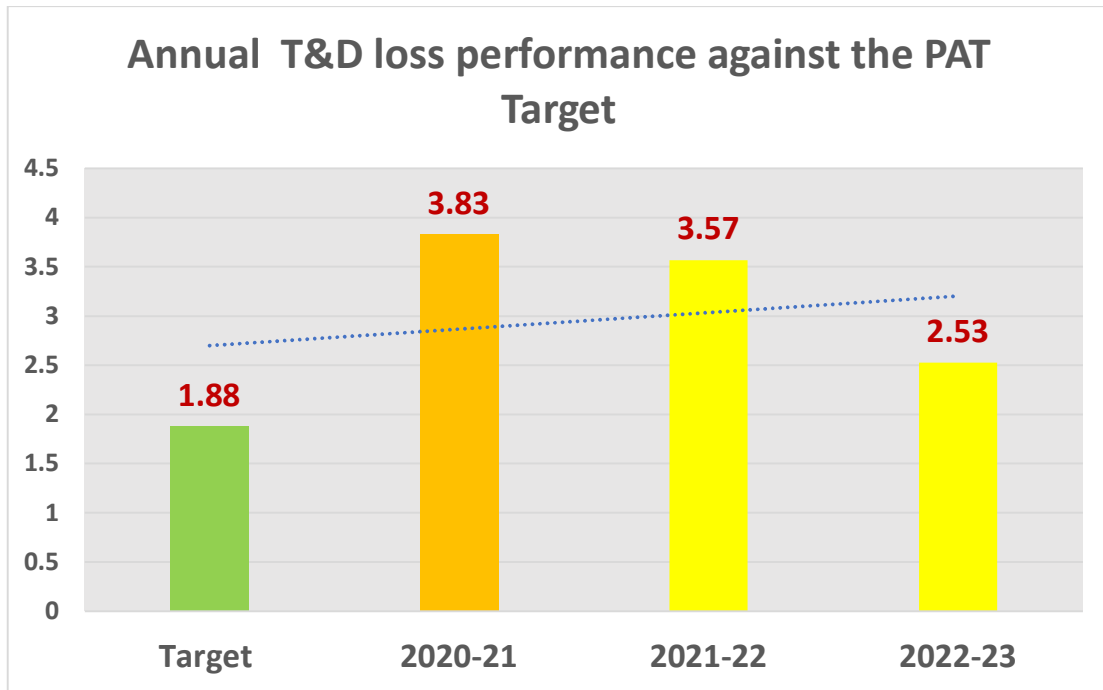

Fig 6

**Quarter Wise T&D Loss performance for the year 2022-23**

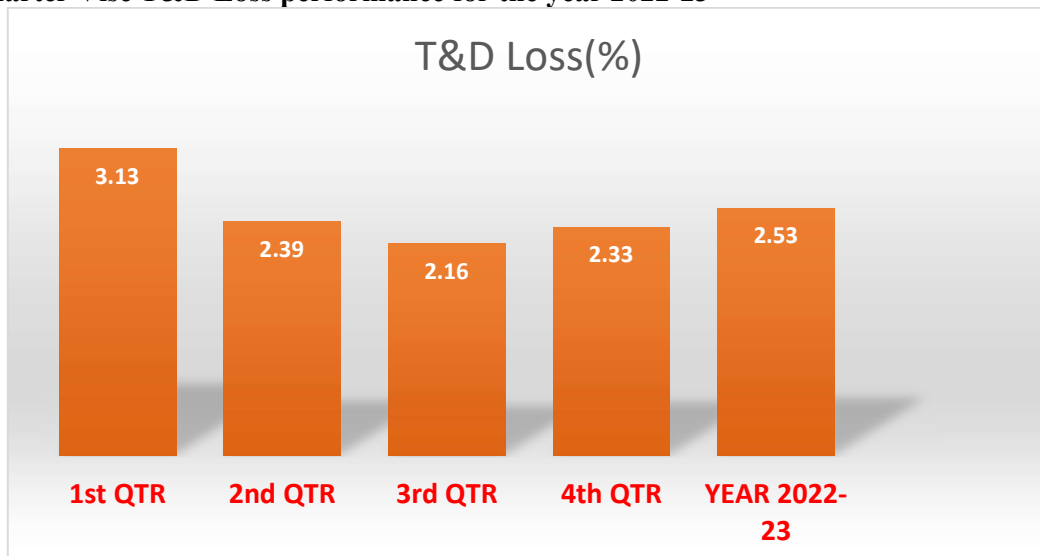

Fig 7

## 5.2.4 Loss analysis of the Two Distribution areas under the CoPA for the FY 2022-23

### Month wise T&D loss performance for the two distribution areas

Month wise T&D loss performance of the Willingdon Island and Vallarpadam area.

	WILLINGDON ISLAND			VALLARPADAM		
	Net Energy input (MU)	ENERGY SALE(MU)	T&D LOSS (MU)	Net Energy input (MU)	ENERGY SALE(MU)	T&D LOSS (MU)
May-22	2.63	2.54	0.09	1.04	1.02	0.02
Jun-22	2.67	2.61	0.06	0.89	0.87	0.02
Jul-22	2.15	2.07	0.08	0.72	0.69	0.03
Aug-22	2.03	1.97	0.05	0.70	0.65	0.04
Sep-22	2.00	1.94	0.06	0.65	0.69	-0.04
Oct-22	2.07	1.99	0.08	0.70	0.70	0.00
Nov-22	2.17	2.10	0.06	0.85	0.85	0.00
Dec-22	2.27	2.20	0.07	0.70	0.70	0.00
Jan-23	2.33	2.27	0.06	0.70	0.70	0.00
Feb-23	2.27	2.22	0.06	0.65	0.65	0.00
Mar-23	2.20	2.14	0.06	0.66	0.66	0.00
Apr-23	2.60	2.51	0.09	0.88	0.88	0.01
ANNUAL TOTAL	27.39	26.56	0.83	9.15	9.05	0.10
T& D Loss %			3.03 %			1.09 %

Table 29

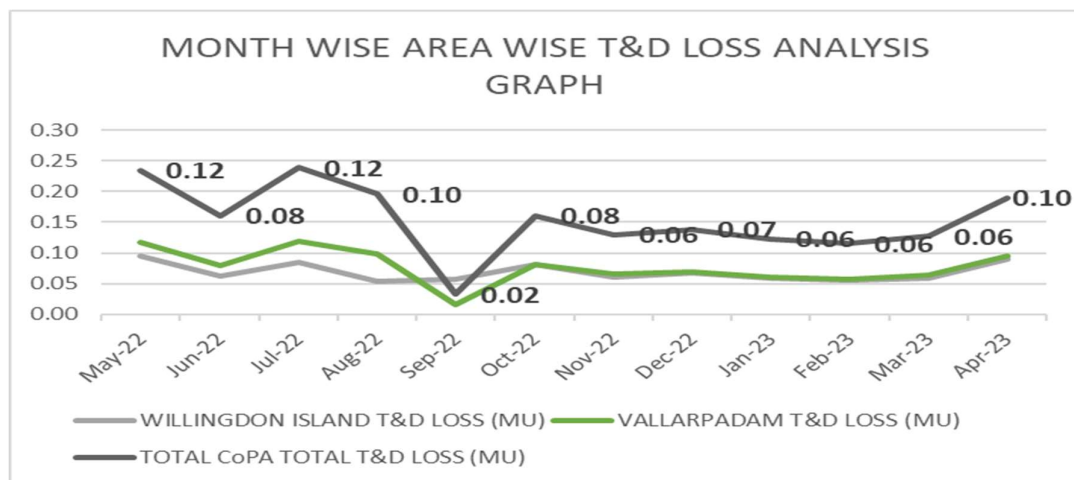

Fig 8

**5.2.5. Feeder wise energy distribution in Willingdon Island**

**(Feeder wise loss could not be assessed due to the absence of functional meters in DTRs.**

**Feeder wise Energy Distribution under the CoPA for the FY 2022-23**

<b>Load distribution through the Feeders from the Wellington substation for the year 2022-23</b>								
	Feeder Name	Feeder Metering Status (Metered/unmetered/AMI/AMR)	Status of Meter (Functional/Non-functional)	Feeder Type (Agri/Industrial/Mixed)	CT/PT ratio	Export (MU)	Import (MU)	
1	MNC	AMI	Functional	Mixed	200/5	0.30	0	
2	NTRO KV	AMI	Functional	Mixed	200/5	2.50	0	
3	Q9 1	AMI	Functional	Mixed	200/5	6.69	0	
4	Q92	AMI	Functional	Mixed	200/5	4.40	0	
5	MH2	AMI	Functional	Mixed	200/5	2.45	0	
6	UTL	AMI	Functional	Mixed	200/5	2.59	0	
7	Q93	AMI	Functional	Mixed	200/5	2.30	0	
8	MH3	AMI	Functional	Mixed	200/5	0.00	0	
9	STN TR	AMI	Functional	Mixed	200/5	0.08	0	
10	PENNA	AMI	Functional	Commercial	200/5	4.80	0	
11	NTRO A2	AMI	Functional	Mixed	200/5	0.91	0	
			Total				27.01	

**Table No:30**



**5.3. Subsidy computation and analysis based on the quarterly data**

**In CoPA there is no subsidy payment from Government.**

**5.3.1 The category wise consumption and revenue realisation for the FY 2022-23**

Period From 1st April 2022 to 31st March 2023								
Consumer profile			Energy parameters		Commercial Parameter			Average billing rate
Consumer category	Total Number of connections (Nos)	% of number of connections	Total energy	% of energy consumption	Billed Amount in Rs. Crore	Collected Amount in Rs. Crore	Collection Efficiency	
Residential	428	34%	0.926641	3%	0.602286	0.602286	100.00%	6.499671
Agricultural	0	0%	0	0%	0	0	0.00%	0
Commercial/Industrial-LT	582	46%	3.675433	10%	4.91468	4.91468	100.00%	13.3717
Commercial/Industrial-HT	29	2%	26.22357	74%	28.58328	28.58328	100.00%	10.89984
Others	217	17%	4.785379	13%	4.189846	4.189846	100.00%	8.755516
	<b>1256</b>	<b>100%</b>	<b>35.61103</b>	<b>100%</b>	<b>38.2901</b>	<b>38.2901</b>	<b>100.00%</b>	<b>10.75231</b>

**Table No:31 A**

## 5.3.2 Quarter wise and Category wise revenue realisation for the Year 2022-23

Period From 1st Oct 2022 to 30th Dec 2022												
S.No	Name of circle	Name of Division	Consumer profile		Energy parameters		Losses		Commercial Parameter			AT & C loss (%)
			Consumer category	led energy (M)	Total energy consumption	% of energy consumption	T&D loss (MU)	T&D loss (%)	Billed Amount in Rs. Crore	Collected Amount in Rs. Crore	Collection Efficiency	
1	CoPA	QTR 1	Residential	0.241836	2%				0.13828064	0.13828064	100.00%	
			Agricultural	0	0%				0	0	0.00%	
			Commercial/Industrial-LT	0.951981	10%	0.316613	3%		1.2664596	1.2664596	100.00%	
			Commercial/Industrial-HT	7.365408	75%				6.9921523	6.9921523	100.00%	
			Others	1.23035	13%				1.05132699	1.05132699	100.00%	
			<b>9.789575</b>	<b>100%</b>	<b>0.316613</b>	<b>3%</b>	<b>9.44821953</b>	<b>9.44821953</b>	<b>100.00%</b>	<b>3%</b>		
2	CoPA	QTR 2	Residential	0.210166	3%				0.12904683	0.12904683	100.00%	
			Agricultural	0	0%				0	0	0.00%	
			Commercial/Industrial-LT	0.870673	11%	0.194729	2%		1.15613575	1.15613575	100.00%	
			Commercial/Industrial-HT	5.743311	72%				6.2006237	6.2006237	100.00%	
			Others	1.128391	14%				0.97010768	0.97010768	100.00%	
			<b>7.952541</b>	<b>100%</b>	<b>0.194729</b>	<b>2%</b>	<b>8.45591396</b>	<b>8.45591396</b>	<b>100.00%</b>	<b>2%</b>		
3	CoPA	QTR3	Residential	0.223117	3%				0.13828064	0.13828064	100.00%	
			Agricultural	0	0%				0	0	0.00%	
			Commercial/Industrial-LT	0.935392	11%	0.195449	2%		1.2664596	1.2664596	100.00%	
			Commercial/Industrial-HT	6.457992	73%				6.9921523	6.9921523	100.00%	
			Others	1.20415	14%				1.05132699	1.05132699	100.00%	
			<b>8.820651</b>	<b>100%</b>	<b>0.195449</b>	<b>2%</b>	<b>9.44821953</b>	<b>9.44821953</b>	<b>100.00%</b>	<b>2%</b>		
4	CoPA	QTR 4	Residential	0.251522	3%				0.16335202	0.16335202	100.00%	
			Agricultural	0	0%				0	0	0.00%	
			Commercial/Industrial-LT	0.935796	10%	0.216217	2%		1.21663406	1.21663406	100.00%	
			Commercial/Industrial-HT	6.6384526	73%				7.4334231	7.4334231	100.00%	
			Others	1.222488	14%				1.07147926	1.07147926	100.00%	
			<b>9.0482586</b>	<b>100%</b>	<b>0.216217</b>	<b>2%</b>	<b>9.88488844</b>	<b>9.88488844</b>	<b>100.00%</b>	<b>2%</b>		

Table No: 31 B

**5.3.3 Trend analysis**

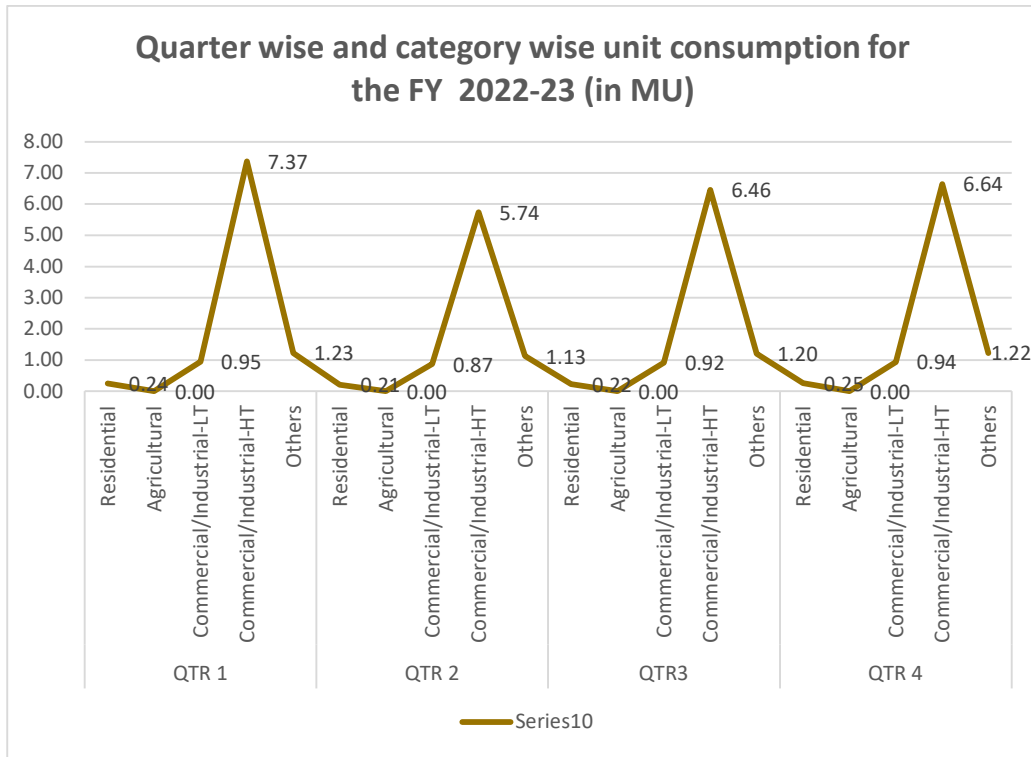

Fig No: 9

**5.3.4 Average billing rate**

As per the revenue analysis the average billing rate per consumer under the CoPA is Rupees 10.75.

## 6. Energy audit Findings

### 6.1 Review of capacity of the DISCOMS energy accounting and audit cell.

As per BEE regulations the DISCOM has formed a centralised energy accounting and audit cell. The entire consumers are installed with advanced SMART meters with AMI feature, except few streetlight meters and self-consumption meters. In addition, there is a centralised AMI server for capturing the meter reading from the SMART meters. This server is also connected with the accounting SAP system. But Quarterly energy accounts are prepared by the DISCOM manually, by collecting data from the accounts and field.

While analysing the losses in the two distribution areas, the losses found very low and even negative (in September 22) in Vallarpadam area. (Refer fig 8). The reason for the low losses is to be analysed properly. This may be due to an error in the consumer mappings.

Based on the audit observation, there is a slight mismatch in the revenue collection and actual unit sale due to different criteria being employed by the accounts and the audits. The regular financial accounts data is from April 22 to March 23. Whereas the audit data is from May 22 to April 23.

Actual revenue against the unit sale is to be made in each month. Besides, as per BEE regulation month wise energy account statement is to be prepared for each month.

As per account report, the collection efficiency is 100 % for all category of consumers. Collection efficiency is to be accounted against unit sale, based on the collection within the stipulated time. Presently there are some pending arrears from the Government consumers like Police.

Though SMART meters with prepaid facility are installed by the DISCOM, the implementation of the prepaid facility is not activated. Activation of the prepaid billing as per the time line set by the BEE is to be followed

### 6.2. Critical Analysis by Energy Auditor

As per the regulations, the compliance of the DISCOM was verified for the status and progress to prerequisites, reporting requirements and other technical aspects and the compliance status are furnished below with detailed responses of the DISCOM Management.

#### 6.2.1 Status and progress in compliance with the prerequisites for energy accounting

S.NO	Parameters verified as per the Energy audit regulation for the DISCOM 2021	Relevant regulation number	Whether the DISCOM Complied or not	Comments by the DISCOM management
1	Pre-requisites for annual energy audit and periodic energy accounting	Reg No: 5		
a)	The identification and mapping of all of the electrical network assets;	Clause (a)	Not yet completed The mapping of feeders, DTR and	The work is proposed under the RDSS Scheme.

			consumers are pending.	
(b)	The identification and mapping of high tension and low-tension consumers;	Clause (b)	Not fully completed.	Proposed under the RDSS Scheme.
(c)	The development and implementation of information technology enabled energy accounting and audit system, including associated software.	Clause (c)	Not fully complied.	Proposed under the RDSS Scheme. Presently the quarterly and annual Energy account reports are prepared based on the AMI software and SAP System.
(d)	100% Communicable Feeder Metering integrated with AMI, by 31 st December 2022 along-with replacement of existing non-communicable feeder meters.	The first schedule. Trajectory for meter installation	Not yet complete.	Proposed under the RDSS Scheme
(e)	All Distribution Transformers (other than HVDS DT up to 25kVA and other DTs below 25 kVA) shall be metered with communicable meters. Communicable DT Metering for the following areas / consumers to be completed by December 2023 and in balance areas by December 2025:		Not yet complied.	Proposed under the RDSS Scheme.
(f)	All Electricity Divisions of 500 AMRUT cities, with AT&C Losses > 15 %		Not Applicable.	
(g)	All Industrial and Commercial consumers;		Yes complied.	All HT and LT Consumers are fitted with SMART Meters with AMI features.
(h)	All Government offices at Block level and above;		Yes complied.	
(i)	Other high loss areas i.e. rural areas with losses more than 25% and urban areas with losses more than 15%.		Not applicable	
(j)	Further, existing non-communicable Distribution Transformer meters to be replaced with communicable meters		Not applicable	

	integrated with AMI, within the timelines applicable to the respective areas			
(iii)	Prepaid Smart Consumer Metering to be completed for all directly connected meters and AMR in case of other meters, by December 2023 in the following areas:		Yes complied.	The SMART Meter installed have prepaid facility.
(a)	All Electricity Divisions of 500 AMRUT cities, with AT&C Losses > 15%		Not applicable	
(b)	All Industrial and Commercial consumers;		Yes	
(c)	All Government offices at Block level and above;		Yes complied.	
(d)	Other high loss areas i.e. rural areas with losses more than 25% and urban areas with losses more than 15%.		Not applicable	
(iv)	Targets for the installation of functional meters.	Year	2022-23	
	Meter type	Target	Achievement	Remarks
(a)	Feeder metering (%)	98.5%	73 % (11/15)	Proposed under the RDSS Scheme.
(b)	DT metering (%)	90%	0%	Do
(c)	Consumer metering (%)	93%	100 %	Complied.
(v)	Whether created a centralized energy accounting and audit cell comprising of— (i) a nodal officer, an energy manager and an information technology manager, having professional experience of not less than five years; and (ii) a financial manager having professional experience of not less than five years	Regulation 5(g)	Yes complied.	The DISCOM has a centralised energy accounting and audit cell comprising of a Nodal officer, Energy Manager, I.T Manager and a Financial Manager.

Table 32 A

### 6.2.2 Status and progress in compliance with the reporting requirements of the regulation (Refer regulation No: 6)

	Parameters verified as per the Energy audit regulation for the DISCOM 2021	Relevant regulation number	Whether the DISCOM Complied or not	Comments by the DISCOM management

(i)	Every electricity distribution company shall designate a nodal officer, who shall be a full-time employee of the electricity distribution company in the rank of the Chief Engineer or above, for the purpose of reporting of the annual energy audit and periodic energy accounting and communicate the same to the Bureau.	Regulation No: 6(1)	Yes complied.	Shri Ajayakumar R.S, Executive Engineer is the Nodal officer.  Cochin Port Authority is a small distribution licensee with hardly 1256 consumers under the port area. Hence the nodal officer is in the rank of an Executive Engineer.
(ii)	Every electricity distribution company shall ensure that the energy accounting data is generated from a metering system or till such time the metering system is not in place, by an agreed method of assumption as may be prescribed by the State Commission	Regulation No: 6(2)	Yes complied.	The energy accounting data is generated from metering system. Hence there are no assumptions.
(iii)	Metering of distribution transformers at High Voltage Distribution System up to 25KVA can be done on cluster meter installed by each electricity distribution company	Regulation No: 6(3)	Not applicable.	There is no HVDS in CoPA.
(iv)	The energy accounting and audit system and software shall be developed to create monthly, quarterly and yearly energy accounting reports.	Regulation No: 6(4)	Not complied to the fullest extent.	The installation of functional meters for the feeders and DTRs are yet to complete. Presently, all the consumer meters and 11 Nos of Feeders are installed with SMART meters. In CoPA, AMI Software is used to fetch data from smart meters installed at consumer premises and integrated with SAP system. Monthly Invoices are generated from SAP by accounts Department.

				Various reports including preparation of energy audit and accounting reports are generated from SAP system with manual intervention.
(v)	Every electricity distribution company shall provide the details of the information technology system in place as specified in clause (f) of regulation 5 that ensures minimal manual intervention in creating the energy accounting reports and manual intervention of any nature, in respect of the period specified therein, shall be clearly indicated in the periodic energy accounting report.	Regulation No: 6(5)	Not yet complied.	In CoPA, AMI Software is used to fetch data from smart meter and same software is integrated with SAP. In the Finance department, SAP is used to generate Monthly invoice for the individual consumers. Presently the energy account and audit reports are prepared manually using the SAP and AMI Software data. The information technology system as per clause (f) of regulation 5 is proposed under the RDSS system

Table 32 B

### 6.2 3. Management Analysis

The key aspects of the regulations are, the conduct of the annual energy audit in DISCOMs by an external accredited auditor every year and submission of regular quarterly energy account report to the BEE and to the SDA prepared by the Energy Manager of the DISCOM within the time frame. There are clear guidelines in regulation for the preparation of quarterly accounts and the manner of conducting energy audit. The Energy accounting for all energy inflows in the distribution system, including renewable energy generation, open access consumers, and energy consumption by the end consumers, shall be conducted on a periodic basis. This necessitates the availability of energy accounting data at consumer, transformer, feeder and system level. Energy accounting will help the DISCOM to identify areas of heavy loss and



pilferage, and thereafter, focused efforts can be made by the DISCOMs to take corrective action.

On scrutiny of the prerequisite conditions, reporting requirements and other technical and commercial aspects, the following observatory remarks are made by the Energy auditor for which reply has been submitted by the Management of the DISCOM.

Regarding the negative T&D loss issue in Vallarppadam area in the month of September 2022, the management has explained that, the reason may be due to the slight mismatch in the energy accounting of the KSEBL and the CoPA. The consumptions are recorded in CoPA, by the SMART meters and will record from 00 hrs on each day. While the KSEBL energy accounting is done by way of manual energy meter reading and hence there is a delay in accounting the same in each month. Moreover, the number of consumers in the Vallarppadam area is very few, which has resulted in low loss figure

Summary of the critical observation made by the Energy auditor and the management response analysis are furnished below:

1. While analysing the loss on quarterly or annual basis, there is no negative loss figure in the Vallarppadam area. Hence the explanation submitted by the Management about the error in the Monthly loss figure in Vallarppadam area, due to the mismatch in the energy account is satisfactory.
2. The mapping of consumers with DTR and Feeders is the prime requirement for the Energy accounting of Feeders and Distribution Transformers. This is essential for tracking the loss and weak points of the DISCOM. But the mapping of the consumers with DTR and Feeders are yet to completed in CoPA.  
The Management has reported that the mapping work will be complete by the DISCOM along with the completion of feeder meters proposed under the RDSS scheme. The management has also promised to complete the task by the year 2024-25.
3. As per the trajectory set by the regulation, the installations of functional meters for all feeders shall be completed by the DISCOM before 31<sup>st</sup> December 2022. But it is seen that, CoPA has installed functional meters only in 11 feeders out of the 15 feeders. Moreover, the feeders are arranged in Ring main system consisting of multiple feeders. There is no proper monitoring system for the ring arrangement. This is a major bottle neck for assessing the feeder wise energy accounting. The

Energy auditor has recommended a proper monitoring system for the Ring main arrangement with optimal load distribution in the feeders.

The DISCOM management has replied that the installation of functional meters in all the feeders are the top priority and the same will be completed by the DISCOM before 31<sup>st</sup> December 2024. Further, arrangements will be made for proper monitoring of the Ring network with optimal load distribution in the 11 kV feeders.

4. Presently no meters are installed in DTR in CoPA. –

The Management of the DISCOM has explained that the DTR meter installations are already proposed under the RDSS scheme and will be completed before 31st December 2024.

5. Installation of SMART prepaid meters for the LT and HT consumers:

The CoPA has already completed the work for the consumers. These meters are connected with an AMI software through mobile network using GPRS . This is a major advantage for CoPA.

6. Formation of Centralised energy auditing and accounting cell

CoPA has a Centralised Energy auditing and accounting cell consisting of a Nodal officer, Energy Manager, IT Manager and the Financial Manager.

7. The CoPA is a small distribution licensee with hardly 1256 consumers in two separate areas without any border sharing. Hence energy accounting is relatively easy. The 74 % of the energy consumption is by the Commercial sectors.

8. Subsidy account: There is no subsidy payment by the Government.

9. The 11 kV distribution is through UG cables with RMU system. The loading in feeders are also low. Hence the distribution loss will be relatively low in feeders.

10. One major observation made by the Energy auditor is that majority of the Distribution transformers are old with higher capacity compared to the load requirement. On, sample verification of DTR load an unbalance is seen in the LT feeding. Hence there is scope for loss reduction in DTR through load balancing.

The management explained that CoPA has already proposed the replacement of 20 Transformers with energy efficient transformers and has also ensured that immediate action will be initiated for regular load monitoring and balancing of load in distribution transformers.

11. The CoPA is not yet equipped with a software for the energy account and audit without manual intervention.

The Management explained that all the consumers are fitted with SMART Meters with AMI feature. Moreover, all SMART meters are connected with AMI software through GPRS system. The AMI software is integrated with the SAP system. Hence system loss assessment is prepared manually based on the data from the SAP system. Further, the creation of software for Energy accounts as stipulated by the regulation is proposed under the RDSS scheme and will be completed by the year 2024-25.

**6.3. Revised findings based on the data validation and field verification and corrective action proposed.**

As per the BEE regulation, energy flow is to be monitored at all voltage levels. But based on the data validation and field verification, the following observations are made for necessary corrections.

1. There is no input meter on the DISCOM side for the 110 kV supply input at the Willingdon Island and the 11 kV supply input at Vallarpadam. The monthly meter readings are recorded in the CoPA register, while taking the meter reading by the KSEBL. Also input energy is accounted from the purchase bill. Hence functional meters are to be installed at the supply input points on the 11 kV side, both at the Willingdon Island and at Vallarpadam. This is essential for energy audit purpose.
2. The 11 kV distribution is connected in Ring main system by connecting multiple feeders for ensuring better supply reliability. But there is no proper monitoring system for the Ring feeding arrangement. This makes it difficult for the load assessment in feeders. Hence for assessing the feeder wise load and loss the following measures to be adopted:
  - a. All the ring networks are to be properly defined based on the optimal load condition in the feeders with separate identification number for each ring and subring.
  - b. There shall be proper monitoring for the ring main network operations from the substation or from other control centre. Ring network diagram is to be placed in the substations.
  - c. Border meter has to be installed at the identified feeder changing points in the ring network.
  - d. Consumer, DTR and feeder mapping has to be completed at the earliest.
3. Feeder meter installations are to be completed on top priority.
4. On scrutiny of the quarterly account report, the following anomalies are noted:
  - a) Feeder energy is found recorded in the Import column. This to be corrected as export energy since the supply is going out from the substation.
  - b) Small quantum of DG energy is found clubbed with the Renewable energy input. This is to be separately added as energy from small capacity conventional plant in the LT level category.
  - c) High-capacity transformers are used for feeding the load and based on sample verification, majority of the Transformers are found underloaded.

- d) On sample verification of the peak load measurement on transformers, the Transformer LT supply is found in unbalanced conditions.

#### **.6.4 Inclusion and exclusion.**

There is no inclusion or exclusion of energy input or sale particulars.

#### **6.5 Recommendations for Loss reduction**

Energy losses occur in the process of supplying electricity to consumers due to technical and commercial reasons. The technical losses are due to energy dissipated in the conductors, transformers and other equipment's used for transmission, , sub-transmission and distribution of power. These technical losses are inherent in a system and can be reduced to a certain level.

Pilferage by hooking, bypassing meters, defective meters, errors in meter reading and in estimating un-metered supply of energy are the main sources of the commercial losses. When Commercial losses are added to Technical losses, it gives Transmission & Distribution (T&D) loss.

There is another component of commercial losses, which is attributable to non-recovery of the billed amount and is reflected in collection efficiency. T&D losses together with loss in collection give us Aggregate Technical & Commercial (AT&C) losses.

Based on the field visit and sample load study on the Transformer loading under the CoPA, the following recommendations are offered for the loss reduction:

#### **Low cost and high yield saving proposals**

1. Unbalanced load condition in transformers.  
On sample load verification in transformers, it is observed that, there is heavy unbalance load conditions in some transformers. Balancing the load will substantially reduce the loss. Hence transformer load is to be monitored on regular interval and load balancing to be undertaken.
2. Under loaded transformers: - On sample verification it is observed that, high capacity DTR are employed in majority of the locations, when compared to the actual load. Hence, load has to be redistributed among transformers based on the best efficiency conditions. While procuring new energy efficient transformers, transformer capacity is to be selected based on the actual load requirement.
3. Tighten all loose joints at the transformer cables and service lines to reduce joint loss.
4. Check the transformer earthing and also measure the neutral current on regular intervals.

#### **Medium cost and high yield energy saving measures**

1. Conductor change: -Replace old conductors with higher cross section new conductors.
2. Provide appropriate power factor compensation capacitors on the secondary side of the distribution transformers.
3. Convert long and loaded single-phase line to three phase line.
4. Convert loaded long three phase line to HT line by installing transformer near the load centre.

#### **Best practises in Distribution management**

1. Feeder automation with automated switches in Ring main unit. The existing Ring main unit can be converted as SCADA compatible RMU.
2. Implementation of Advanced SCADA System in Distribution.
3. Implementation of advanced EMS (Energy Management Software for the optimal load management and energy accounting).

## 7. Conclusion and action Plan

### 7.1. Summary of the Critical Analysis by Energy Auditor

The key aspect of the regulations is the conduct of the annual energy audit in DISCOMs by an external accredited auditor in every year and submission of regular quarterly energy account report to the BEE and to the SDA prepared by the Energy Manager of the DISCOM within the time frame. There is clear guide lines in the regulation for the preparation of quarterly accounts and the manner of conduct of the energy audit. The Energy accounting for all energy inflows in the distribution system, including renewable energy generation, open access consumers, and energy consumption by the end consumers, shall be conducted on a periodic basis. This necessitates that energy accounting data is made available at a consumer, transformer, feeder and system level. Energy accounting will help the DISCOM to identify areas of high loss and pilferage, and thereafter, focused efforts can be made by the DISCOMs to take corrective action

On scrutiny of the prerequisite conditions, reporting requirements and other technical and commercial aspects, the following observatory remarks are made by the Energy auditor for which reply has been submitted by the Management of the DISCOM. Summary of the critical observation made by the Energy auditor and the management response analysis are furnished below:

1. The mapping of consumers with DTR and Feeders is the prime requirement for the Energy accounting of Feeders and Distribution Transformers. This is essential for tracking the loss and weak points of the DISCOM. But the mapping of the consumers with DTR and Feeders are yet to be completed in CoPA. The Management has reported that the mapping work will be complete by the DISCOM along with the completion of feeder meters proposed under the RDSS scheme. The management has promised to complete the task by the year 2024-25. The Management also ensured that it will check the reason for the variation in the T&D loss in the Vallarpadam area.
2. As per the trajectory set by the regulation, the installations of functional meters for all feeders shall be completed by the DISCOM before 31<sup>st</sup> December 2022. But CoPA installed functional meters only in 11 feeders out of the 15 feeders. Moreover, the feeders are arranged in Ring main system consisting of multiple feeders. There is no proper monitoring system for the ring arrangement. This is a major bottle neck for assessing the feeder wise energy accounting. The

Energy auditor has recommended a proper monitoring system for the Ring main arrangement with optimal load distribution in feeders.

The DISCOM management has replied that the installation of functional meters in all the feeders are the top priority and the same will be completed by the DISCOM before 31<sup>st</sup> December 2023. Further, arrangements will be made for proper monitoring of the Ring network with optimal load distribution in the 11 kV feeders.

3. Presently no meters are installed in DTRs in CoPA. –

The Management of the DISCOM has explained that the DTR meter installations are already proposed under the RDSS scheme and will be completed before 31st March 2024.

4. Installation of SMART prepaid meters for the LT and HT consumers:

The CoPA has already completed the work for the consumers. These meters are connected with an AMI software through mobile network using GPRS. This is a major advantage for the CoPA.

5. Formation of Centralised energy auditing and accounting cell

CoPA has a Centralised Energy auditing and accounting cell consisting of a Nodal officer, Energy Manager, IT Manager and the Financial Manager.

6. The CoPA is a small distribution licensee with hardly 1256 consumers in two separate areas without any border sharing. Hence energy accounting is relatively easy. The 74 % of the energy consumption is by the Commercial sectors.

7. Subsidy account: There is no subsidy payment by the Government. The 11 kV distribution is through UG cables with RMU system. Also the loading in the feeders are low. Hence the distribution loss will be relatively low in feeders.

8. One major observation made by the Energy auditor is that majority of the Distribution transformers are old with high capacity compared to the load requirement. On sample verification of DTR load an unbalance is seen in the LT feeding. Hence there is scope for loss reduction in DTR through load balancing. The management explained that the CoPA has already proposed the replacement of 20 Transformers with energy efficient transformers and has also ensured that immediate action will be initiated for regular load monitoring and balancing of load in distribution transformers.

9. The CoPA is not yet equipped with a software for the energy account and audit without manual intervention.

The Management explained that all the consumers are fitted with SMART Meters with AMI feature. Also, all the SMART meters are connected with the AMI software through GPRS system. The AMI software is integrated with the SAP system. Hence system loss assessment is prepared manually based on the data from the SAP system. Further the creation of software for Energy accounts as stipulated by the regulation is proposed under the RDSS scheme and will be completed by the year 2024-25.

## 7.2 Summary of Key findings

As per the BEE regulation energy flow to be monitored at all voltage levels. But based on the data validation and field verification the following observations are made and to be corrected.

1. There is no input meter on the DISCOM side for the 110 kV supply input at the Willingdon Island and at the 11 kV supply input at the Vallarpadam. Presently the input energy is accounted from the purchase bill. And based on the Energy meter reading of the utility. Hence functional meters are to be installed at the supply input points on the 11 kV side both at the Willingdon Island and at Vallarpadam. This is essential for energy audit purpose.
2. The 11 kV distribution is connected in Ring main system by connecting multiple feeders for ensuring better supply reliability. But there is no proper monitoring system for the Ring feeding arrangement. This makes it difficult for the load assessment in feeders. Hence for assessing the feeder wise load and loss the following measures to be adopted.
  - a. All the ring networks to be properly defined based on the optimal load condition in the feeders with separate identification number for each ring and subring.
  - b. There shall be proper monitoring for the ring main network operations from the substation or from other control centre. Ring network diagram to be placed in the substations.
  - c. Border meter has to be installed at the identified feeder changing points in the ring network.
  - d. Consumer, DTR and feeder mapping to be completed at the earliest.
  - e. Feeder meter installations to be completed on top priority.
3. Up on scrutiny of the quarterly account report the following anomalies are noted
4. Feeder energy is found recorded in the Import column. This to be corrected as export energy as the supply is going out from the substation.
5. Small quantum of DG energy is found clubbed with the Renewable energy input. But presently there is no provision to add this in the LT system in the Format. This will be taken up with the BEE.
6. Higher -capacity transformers are found used for Distribution and based on sample verification; majority of the Transformers are found underloaded.

7. Up on sample verification of the peak load measurement on transformers the Transformer LT supply is found in unbalanced conditions

### **7.3 Recommendations and best practises for Energy accounting and loss reduction**

1. Energy losses occur in the process of supplying electricity to consumers due to technical and commercial reasons. The technical losses are due to energy dissipated in the conductors, transformers and other equipment's used for transmission, , sub-transmission and distribution of power. These technical losses are inherent in a system and can be reduced to a certain level.
2. Pilferage by hooking, bypassing meters, defective meters, errors in meter reading and in estimating un-metered supply of energy are the main sources of the commercial losses □when Commercial losses are added to technical losses, it gives Transmission & Distribution (T&D) loss.
3. There is another component of commercial losses, which is attributable to non-recovery of the billed amount, which is reflected in collection efficiency. T&D losses together with loss in collection give us Aggregate Technical & Commercial (AT&C) losses.
4. Based on the field visit and sample load study on the Transformer loading under the CoPA the following recommendations are offered for the loss reduction.

#### **5. Low cost and high yield saving proposals**

6. Unbalanced load condition in transformers. Up on sample load verification in transformers, it is observed heavy unbalance load conditions in transformers. Balancing the load will substantially reduce the loss. Hence transformer load to be monitored on regular interval and load balancing to be undertaken urgently.
7. Under loaded transformers: - Up on sample verification it is observed higher capacity DTR are employed in majority of the locations, when compared to the actual load requirement. Hence load to be redistributed among transformers based on the best efficiency conditions. While procuring new energy efficient transformers, transformer capacity to be selected based on the actual load requirement.
8. Tighten all the loose joints at the transformer cables and service lines, this will reduce joint loss.
9. Check the transformer earthing and also measure the neutral current on regular interval.
10. The load in the two 12.5 MVA Power transformers are found below 30%.Hence switching off one transformer alternatively will reduce the transmission loss.

#### **11. Medium cost and high yield energy saving measures**

12. Conductor changing: Replace old conductors with higher cross section new conductors.
13. Provide appropriate power factor compensation capacitors on the secondary side of the distribution transformers.
14. Convert long and loaded single-phase line to three phase line.
15. Convert long three phase line to HT line by installing transformer near the load centre.



**Best practises in Distribution management**

1. Feeder automation with automated switches in Ring main unit. The existing Ring main unit can be converted as SCADA compatible RMU.
2. Implement Advanced SCADA System in Distribution
3. Implement advanced EMS (Energy Management Software for the optimal load management and energy accounting

## 7.4. 1. Action Plan for monitoring and reporting

Action plan for monitoring and reporting					
S.NO	TASK	Approximate cost	Benefit	Time frame for implementation	Remarks
1	Completion of the Mapping of the Consumers with the connecting DTR		Loss reduction and complying the regulation	31-12-2023	By implementing these tasks, the loss can be segregated on DTR and Feeder wise and which will help to achieve the PAT Target for the utility.
2	Since the 11 kV distribution is through Ring main system, the ring networks to be properly defined with normal feeding arrangement, considering the optimal load through the feeder.		do	31-12-2023	
3	Set up a monitoring system for the Ring operation either at the Substation control room or in another place.		do	31-01-2024	
4	Mapping of the DTR with the Feeders			31-12-2023	
5	Completion of the Feeder meter installations in all feeders			31-03-2024	
6	Incorporation of the DTR and Feeder Mapping DATA in the existing AMI software so that DTR wise and Feeder wise Energy loss statement can be generated			31-01-2024	
7	Completion of the DTR Meter installations	1200000		31-12-2024	

Table No: 33

## 7.4 .2. Action Plan for automated Energy accounting

Action Plan for automation					
1	Task details	Approximate cost	Benefit /Saving	Payback period	Remarks
1	Distribution SCADA implementation	54200000	Advanced load monitoring and control. Better supplier reliability parameters and hence high revenue and customer satisfaction.	To be worked out based on the existing parameters.	
2	Implement the advanced EMS software in the Distribution	1500000	Complete energy management solutions and revenue management.		

**Table No: 34**

## **8. ANNEXURES**

### 8.1 Introduction of the Verification team

The audit is conducted by M/s Centre for Energy, Environment and Productivity (CEEP) an Empanelled accredited auditing firm in DISCOM. The details of the auditing team members are furnished below.

#### AUDIT TEAM

S.NO	Name of the officer	Qualification	Designation
1.	Dr. J. Nagesh Kumar	Ph.D.	Accredited Energy auditor Reg No: 0133
2	Shri Sunilkumar V K	B. Tech (Elec)	Sector expert (DISCOM) & Certified Energy Auditor Reg No: EA 3642
3.	Shri Jagadish Chandran	B.E.	Electrical Auditor
4.	Shri K.G. Diwakar	M.E.	Certified Energy Auditor

Table 35

## 8.2 Minutes of the Meeting with DISCOM

Minutes of the opening meeting conducted in connection with the Mandatory Energy Audit in the Electricity Distribution System of M/s Cochin Port Authority for the FY 2022-23 on 11<sup>th</sup> July 2023 in the chamber of the Chief Mechanical Engineer.

### Minutes of the Discussion

Date - 11/7/2023  
Time - 11 am to 1 pm  
Venue - The chamber of Chief Mechanical Engineer, CoPA, W. Island, Cochin-9  
Subject - Energy Auditing for the year 2022-23 in compliance with BEE Regulation  
Presided by - Chief Mechanical Engineer

### Participants

#### **Cochin Port Authority**

1. Shri. V.Thurai Pandian, CME, CoPA
2. Shri. R.S. Ajayakumar, EE(Ele)D.O
3. Shri. Ajithkumar, D. EE(Ele)P
4. Smt. Humble Ursala John, EE(Ele)
5. Smt. Jaysalakshmy S, AEE(Ele)
6. Smt. Mini V, AEE(Ele)
7. Smt. Armina Azeed M.A, AE(Ele)
8. Shri. Mathew Paul, AE(Ele)
9. Shri. Johny Alumparambil, AE(Ele)

**M/s Centre For Energy Environment and Productivity, Chennai, Accredited Energy Auditor for DISCOMS.**

1. Shri. Sunilkumar V.K- Sector Expert (DISCOM) & CEA
2. Shri. Jadhish Chandran, Electrical Auditor

Ref : 1. Contract No: GEMC-511687768985203 dated 04<sup>th</sup> July 2023

2. **Centre For Energy Environment and Productivity, Chennai** mail dated 07/07/2023

Cochin Port Authority has awarded contract for conducting Annual Energy Auditing and Periodic Energy Accounting, in compliance with the BEE Regulation to M/s Centre For Energy Environment and Productivity, Chennai. Accordingly a meeting has been convened with AEA Representative Sri. Sunilkumar V.K Sector Expert (DISCOM) on 11/07/2023.

CME welcomed the AEA and all the officers and appraised the necessity of conducting the Annual Energy Audit within the time schedule as stipulated by the BEE i.e on or before 31/07/2023. CME has directed all the Engineers to coordinate with the AEA for the smooth conduct of the Annual Energy Audit and Periodic Accounting for the year 2022-23.

Followed by this Shri Sunilkumar V K the Sector Expert (DISCOM & CEA) of M/s CEEP, Chennai has briefed about the BEE DISCOM Audit Regulation 2021 and the necessity for complying with the requirements within the time frame for avoiding the penalty. He has also explained the mode of conduct of the audit as follows :

- Compliance check for the prerequisite conditions of energy account in CoPA (as per regulation 5)
- Compliance check of the reporting requirement of the annual energy audit and periodic energy accounting in CoPA (as per regulation 5)
- Verification of the quarterly energy account of the CoPA for the four quarters of the year 2022-23 prepared by the Energy Manager.
- Verification of the actual energy purchase and net input energy injected in to the DISCOM periphery – (Documents required -annual report/purchase bill and Internal energy energy details )
- Verification of the category wise and voltage wise actual energy sale for the year 2022-23
- Site visit and sample check of the meter readings , meter installation details and calibration status
- Verification of the Energy conservation measures implemented in CoPA

The chair informed that the installation of the DTR meters, remaining Feeder meters and SCADA system for complying with automated energy accounting as per BEE Regulation has been taken up in the RDSS scheme and will be completed as per the schedule.

Meeting closed at 1:00 PM.

  
Chief Mechanical Engineer  
Cochin Port Authority

**8.3 Check list prepared by the Empanelled Accredited auditing Firm**

CENTRE FOR ENERGY, ENVIRONMENT AND PRODUCTIVITY				Form No: MEADC 001 Rev 0		
Check list for energy audit prepared by the Em AEA						
S.NO	Parameter	Unit	Qty	Ref document	Compliance/result	Proposed Target date if not complied
1	Verification for the Progress of meter installation	No		Trajectory for meter installation. First schedule (Regulation (5d)).		
2	Verification of the compliance of the prerequisites for the energy audit and energy accounting			Regulation 5		
3	Verification of the existing pattern of energy distribution across the periphery of electricity distribution company			Energy account report from DISCOM, Tariff petition filed by the DISCOM		NA
4	Verification of accounted energy flow submitted by the Electricity distribution company at all voltage levels			do		NA
5	Validation of data through sample data checks			Report submitted by the DISCOM, and sample check at site		NA
6	Voltage wise and consumer wise			Do		NA
7	Category wise subsidy notified by the Government			Do		NA
8	Voltage wise and category wise subsidy demand & receipt			Do		NA
9	Verification of the Circle wise and Division wise Data			Do		
10	Verification of the calibration details of the meters					
11	Verification of the previous year energy audit and account details			Previous year account and audit report submitted to the BEE, by the DISCOM		
12	Preparation of the draft report			Second schedule, Regulation no:9(1)		
J.NAGESHKUMAR AEA						

Table 36



## **8.4. Brief approach, Scope and methodology of the audit**

### **I. The objectives of the work**

As per notification No: 18/1/BEE/DISCOM/2021 dated 6<sup>th</sup> October 2021 (Manner and interval for conduct of energy audit (accounting) in Electricity Distribution companies regulations issued by the BEE, MOP and amendment issued thereof on 28<sup>th</sup> October 2022, every Distribution companies shall conduct an annual energy audit by an external accredited auditor for every financial year and submit the annual energy audit report to the Bureau of Energy Efficiency and respective SDA and also made available on the website of the DISCOM within a period of four months from the expiry of the relevant financial year.

The objectives of the work are to conduct a comprehensive energy audit and submit the report containing the details as stipulated by the regulation with recommendations and action plan with time frame and priority to reduce the loss and best practises in energy accounting and energy conservation techniques so as to improve the efficiency and the financial viability of the DISCOM

### **II. Approach and methodology of the work**

The proposed audit will be conducted in the following three phases.

#### **1. Pre-audit phase**

- I. Discussion and review meeting(s) with DISCOMs and Energy Manager(s) to ensure reliable and timely data availability
- II. A review of the Macro level data in order to assess the areas of high losses and data gaps
- III. Planning field visits to verify and collect data
- IV. Planning and phasing of various steps involved in audit exercise including data collection, manpower/team deployment,
- V. Organizing the structure of the audit report in consonance with energy accounting regulations notified by BEE; and the output required for corrective action and decision making
- VI. Undertake a review of the capacity of the centralized energy accounting and audit cell created at the DISCOM in terms of adequate representation from professional backgrounds of IT Manager, Energy Manager and Financial Manager

#### **2. Audit phase**

- a) Review of present structure of energy flow in DISCOM at different levels - State level, transmission, sub-transmission, DT level, feeder level to end consumer etc.

Capture details of DISCOM infrastructure - no. of circles, divisions, sub-divisions, sections, Substations, total No. of Power Transformers with capacity in MVA, total No. of Capacitor Banks in Substations and capacity in MVAR, feeders, DTs with capacity in MVA, boundary meters, category wise consumers and

- b) Voltage level for each consumer category etc. (Refer Regulation 5)

- c) Stakeholder interactions with DISCOM, Energy Manager, SE (Circle level), XEN (Division level) for data accuracy and other issues.
- d) Verify, check and validate current metering status (operational/ faulty/ unmetered) and type (communicable/ static etc.) at various voltage levels (feeders, DTs, consumers) and Metering details (such as Meter Sl. Number, Meter reading date and the Mu34ltiplying Factor) through sample field visits and available records with DISCOM.
- e) Verification of energy flow data within DISCOM at all applicable voltage levels (Refer Regulation 7) of distribution network as specified in the regulations. The service level wise energy flow data is to be computed by the DISCOM on a monthly basis, and it would submit a consolidated Quarter wise report to the Energy Auditor, who would only verify the same
- f) Validation through sample data checks and field visits:
  - a. Validation of feeder data: Based on data available in 11 kV Feeder meter at substation for a sample size of 10% for which documentary evidence will be captured in the audit report.
  - b. Validation of energy flow data and losses: Based on field survey as per the following sample size:
    - I. Min. 10 or 1% (whichever is higher) of DISCOM's input energy metering points between Transmission and 66kV/33kV/11kV distribution feeders by checking functional and communication status of meters etc.
    - II. For all Divisions with AT&C losses greater than 25% or at-least 1/3 of the total Divisions of DISCOM, verify: - Total of min. 10 or 1% of metering points (whichever is higher) between 220-132-110- 66 /33 kV outgoing and 22kV-11kV-6.6kV-3kV incoming feeders/ direct end consumer by checking functional and communication status of meters.
    - III. In an Urban High Loss Division, check 5 or 1% of Metering points (whichever is higher) at DTs where communicable meters were already installed under other schemes such as R-APDRP and IPDS.
    - IV. Total of min. of 10 or 1% of metering points (whichever is higher) between 11kV/6.6kV feeders and DTs by checking functional and communication status of meters, foot survey of feeder to check for thefts/ hooking etc.
    - V. Verify metering and connection status of min. of 10 or 2% consumers of the Division (whichever is higher) of the following category of consumers – Agriculture (Metered and Un-metered), Govt. category connection (ULB, RLB etc.), and LT Industrial

g) Computation of AT&C losses for each division:

I. Input energy data: Identification of all input points of transmission system, collection of input energy from recorded system, meter reading including energy received and distributed by DISCOM, recorded meter reading at all DISCOM export points, system loading, source of energy supply including generation from RE, etc.

II. Billing and collection data: Feeder wise and category wise no. of consumers, Voltage Level for every consumer category, metered and un-metered, connected load, billed and unbilled energy, details of open access, EHT sale, HT sale, LT sale and transmission losses, etc.

III. Computation of distribution loss, collection efficiency and AT&C loss at Feeder level, DT Level and Utility level

I.

a.	<b>T&amp;D LOSS</b> = (NET INPUT ENERGY - TOTAL ENERGY BILLED )	
b.	<b>BILLING EFFECIENCY (%)</b> =(TOTAL ENERGY BILLED /NET INPUT ENERGY )	
c.	<b>COLLECTION EFFECIENCY (%)</b> ={ AMOUNT COLLECTED /AMOUNT BILLED }	
d.	<b>AT&amp;C LOSS (%)</b> = (1-BILLING EFFECIENCY X COLLECTION EFFECIENCY)	

IV. Identify high-loss Feeder and network segments: Based on energy loss

V. losses, wastage or inefficient use of electricity etc. for initiating target based corrective action

VI. Identify overloaded segments/ infrastructure: Based on sample assessment and data analysis, make recommendations on undertaking necessary capacity augmentations in substations, Feeders, Transformers and up to consumer end as observed.

h) Computation of subsidy assessed based on energy accounting data:

i) Revise the findings accordingly as per the field visits undertaken as mentioned above

j) Trend analysis with quarterly audit findings, past data review

k) Exception analysis and aberrations if any observed in audit exercise

### **3. Post Audit and Reporting phase**

- a) Detailed Energy Audit Report preparation and submission as per BEE energy accounting regulations (Refer Regulation 9)
- b) Audit report should include energy accounting data captured on a quarterly basis for the FY.
- c) The audit report should point out variances in quarterly and annual data and recommendations for alignment of periodic accounting and annual energy audit report, key data gaps, assumptions and exceptions.
- d) Wherever available and feasible, validate Energy Audit report with the Energy Audit report generated by the DISCOM for smart meters – for this, the DISCOM would facilitate data/ report availability from the respective AMISP.

**iv. Submit an Action Plan in the Energy Audit Report**, which should necessarily capture the following:

- a) Provide recommendations w.r.t energy accounting, loss reduction, subsidy accounting, consumption analysis etc. This should include cost-benefit analysis, payback periods etc.,
- b) accompanied by a detailed implementation plan and a mechanism for regular review and monitoring so that desired objectives are achieved within stipulated timelines.
- c) Develop a comprehensive action plan for monitoring of energy flow at each voltage level (Refer Regulation 8)
- d) Recommendations to also include that energy accounts prepared and submitted to BEE to be used for financial audit reporting.
- e) Auditor to obtain detailed action plan from the DISCOM to establish an IT enabled system to create energy accounting reports without any manual interference. This should include timelines for completion of Smart metering of Feeders and DTs, and generation of automated energy accounting reports through an IT platform/ solution. Detailed action plan to form part of energy audit report for regular review and monitoring.
- f) Auditor should observe and compile various Energy Conservation options implemented by the DISCOM and prepare report containing details of expenditure done by DISCOM along with saving and payback period.

v. Assessment details and recommendations related to annual energy audit of previous year

## 8.5 Infrastructure details

<b>Form-Details of Input Infrastructure</b>					
S.No	Parameters	Total	Covered during in audit	Verified by Auditor in Sample Check	Remarks (Source of data)
I	Number of circles	1	1	1	In CoPA there is no Circle or Division wise formation. However, the entire CoPA is treated as a Circle.
II	Number of divisions	0			
III	Number of sub-divisions	0			
IV	Number of feeders	15	15	11	List provided by the DISCOM and AMI Software.
V	Number of DTs	30	30	0	List provided by the DISCOM
VI	Number of consumers	1256	1256	126	Through SAP

Table 37

## 8.5.1. Voltage based consumers and metering infrastructure

2	Parameters	66kV and above	33kV	11/22kV	LT
a . i.	Number of conventional metered consumers	0	0	0	88
ii	Number of consumers with 'smart' meters	0	0	36	1132
iii	Number of consumers with 'smart prepaid' meters	0	0	0	0
iv	Number of consumers with 'AMR' meters	0	0	0	0
v	Number of consumers with 'non-smart prepaid' meters	0	0	0	0
vi	Number of unmetered consumers	0	0	0	0
vii	Number of total consumers	0	0	36	1220
b .i.	Number of conventionally metered Distribution Transformers	0	0	0	

ii	Number of DTs with communicable meters	0	0	0	0
iii	Number of unmetered DTs	0	0	30	0
iv	Number of total Transformers	0	0	30	
c .i.	Number of metered feeders	0	0	11	0
ii	Number of feeders with communicable meters	0	0	11	0
iii	Number of unmetered feeders	0	0	4	
iv	Number of total feeders	0	0	15	
d	Line length (ckt km)	0	0	85	105
e.	Length of Aerial Bunched Cables (kM)	0	0	0	0
f.	Length of Underground Cables (kM)	0	0	85	

0

**Table 38**

8.5.2. Detailed list of Transformers

LIST OF TRANSFORMERS						
Sl. No.	Transformer Details				Location	
	Type & Capacity	Make	Maker's Sl.no.	Yr. of mfr.		
1	11 KV/433 V, 630 KVA	KEL	26643	1992	Mattancherry Halt S/s.	Wellington Island
2	11 KV/433 V, 315 KVA	Crompton parkison Ltd	29826V	1975	Mattancherry Halt Qtrs.	
3	11 KV/433 V, 500 KVA	KEL	58942	2008	SBI RMU (Coal Stacking Area)	
4	11 KV/433 V, 250 KVA	Unipower	2263	2011	A3 Area, IMU Campus	
5	11 KV/433 V, 500 KVA	Megawin	947	2014	Subramaniyam Road	
6	11 KV/433 V, 630 KVA	Intrans	T-2676	2019	New Leasing Area	
7	11 KV/433 V, 500 KVA	KEL	4821	1979	110 KV Substation compound	
8	11 KV/433 V, 630 KVA	Talwane	TPE 740	2009	RNAS	
9	11 KV/433 V, 630 KVA	Intrans	T-2677	2018	RNAS	
10	3.3 KV/433 V, 500 KVA	Intrans	T-1653	2012	Hospital Substation	
11	11 KV/433 V, 630 KVA	Intrans	T-2678	2019	Konkan - 2	
12	11 KV/433 V, 250 KVA	Resi Tech	TR-205	2018	Walkway RMU Premise	
13	11 KV/433 V, 315 KVA	Resi Tech	TR-205	2018	Tropicana RMU Premise	
14	11 KV/433 V, 800 KVA	KEL	5115	1981	N.End SSn	
15	11 KV/433 V, 800 KVA			2001	BTP Substation	
16	11KV/3.3KV - 630kVA		Sl.no. 1599, Intrans	2012	E/Wharf :Substation premises	
17	11KV/433V - 500 KVA		Sl.no. 46534, KEL	2002	E/Wharf :Substation premises	
18	11`KV/433V - 630 KVA		Sl.no. 36884	1996	Old leasing Area	
19	11`KV/433V - 630 KVA		Sl.no. 48824, KEL	2004	Old leasing Area	
20	11 KV/433 V - 500 KVA		Sl.no. 5895, Indian Transformers Ltd	1978	SAGARIKA Cruise Terminal	
21	11 KV/433 V -1250 KVA		Sl.no.739	2009	Q9 Substation	
22	11 KV/433 V - 630 KVA		Sl.no.16969	1977	Q5 Substation	
23	11 KV/433 V - 800 KVA		Sl.no. 8333, KEL	1986	Q10 Substation CFS	
24	11 KV/433 V - 500 KVA		Sl.no. 52888	2005	CWC	
25	11KV/3.3 KV, 1250 KVA		TR12, Indoor NPH		NPH	
26	11 KV/3.3 KV, 1000 KVA		TR13, Indoor NPH		NPH	
27	11 KV/433 V, 500 KVA				VALLARPADOM SUBSTATION	Vallarppadam
28	11 KV/433 V, 250 KVA				Near IOC	
29	11 KV/433 V, 315 KVA				Near SEZ Bldg. (Gate)	
30	11 KV/433 V, 300 KVA				MULT	

Table No: 39

## 8.6. Electrical Distribution system

Cochin Port Authority (CoPA) is a Body Corporate under the Major Port Authorities Act, 2021 (formerly Cochin Port Trust).

CoPA is also a Deemed Electricity Distribution Licensee as per Electricity Act 2003 and a notified DC (**DC No: DIS0048KL**) under the PAT Cycle VII vide notification No: S.O.4552(E) dated 26<sup>th</sup> September 2022 by the Ministry of Power, GOI.

CoPA is purchasing electricity from M/s Kerala State Electricity Board Limited, a major distribution licensee and distributes to the consumers in Port area, under its jurisdictional power in Willingdon Island, Vallarpadam & Puthuvypin area. CoPA is availing 6.5MVA power at 110 KV system from KSEBL in Willingdon Island and 3 MVA power at 11 kV Voltage at Vallarpadam and distributing electricity to the consumers within the premises of the Port

Presently, CoPA has a 110kV/11kV Substation with 2Nos 10/12.5MVA power transformers and associated switchgears and control gears at Wellington Island and 11 kV receiving Station at Vallarpadam .11kV power is distributed to the consumers through 11kV UG Cables / dedicated 11 kV UG Cables and linked through Ring Main system for redundancy in supply /providing 24x7 days supply.LT feeding is by means of LT OH/ UG cable lines. At present there are 1256 consumers of which 36 are HT Consumers and 1220 are LT consumers. Consumer metering is 100% SMART meters for all category of consumers. However self-consumption and street light supply are metered through SMART meters/Electronic meters. Action has already been taken to purchase SMART meters to replacing the electronic meters with SMART meters. SMART Meters are with AMI features with prepaid facility. All the SMART Meters are connected to a centralised AMI software system through mobile network using GPRS. The billing and accounting are done using SAP System.

There are eleven 11 KV feeders emanating from 110/11 KV substation at Willingdon Island and four 11 kV feeders at Vallarpadam & Puthuvypin area. There are 30 numbers of 11kV/415Volt and 11 kV/3.3 kV distribution transformers .CoPA has commissioned 100kWp and 150kWp grid connected solar plant . CoPA has also permitted Net metering facility for solar plants of 4 LT and HT Prosumers. Import/Export of energy from the solar plants are accounted through SMART meter. The energy inputs from the solar plants are also covered in the Energy audit.



**8.6.1 .Feeder wise load distribution under the Willingdon Distribution System**

<b>Load distribution through the Feeders from the Willingdon substation for the year 20</b>							
	Feeder Name	Feeder Metering Status (Metered/unmetered/AMI/AMR)	Status of Meter (Functional/Non-functional)	Feeder Type (Agri/Industrial/Mixed)	CT/P T ratio	Export (MU)	Import (MU)
1	MNC	AMI	Functional	Mixed	200/5	0.30	0
2	NTRO KV	AMI	Functional	Mixed	200/5	2.50	0
3	Q9 1	AMI	Functional	Mixed	200/5	6.69	0
4	Q92	AMI	Functional	Mixed	200/5	4.40	0
5	MH2	AMI	Functional	Mixed	200/5	2.45	0
6	UTL	AMI	Functional	Mixed	200/5	2.59	0
7	Q93	AMI	Functional	Mixed	200/5	2.30	0
8	MH3	AMI	Functional	Mixed	200/5	0.00	0
9	STN TR	AMI	Functional	Mixed	200/5	0.08	0
10	PENNA	AMI	Functional	Commercial	200/5	4.80	0
11	NTRO A2	AMI	Functional	Mixed	200/5	0.91	0
			Total			27.01	

**Table 40**

On analysing the feeder loads, major loads are found in 3 feeders namely, Q91 ,Q92 and PENNA. The load in the rest of the feeders are found very low. Hence there is scope for energy saving through optimal load sharing of feeders

**8.6.2 Energy performance of the previous years**

S.NO	Energy input details	Units	2020-21	2021-22
A	Energy purchased	MU	35.581	36.719
B	Net input energy (at DISCOM Periphery after adjusting the transmission losses and energy traded)	MU	35.581	36.719
C	Energy billed	MU	34.219	35.405
D	T& D Loss	MU	1.362	1.313
E	% T&D Loss	%	3.82	3.577

**Table 41**

**8.6.3 Analysis of performance in the two Distribution areas under the CoPA**

	WILLINGDON ISLAND			VALLARPADAM		
	Net Energy input (MU)	ENERGY SALE(MU)	T&D LOSS (MU)	Net Energy input (MU)	ENERGY SALE(MU)	T&D LOSS (MU)
May-22	2.63	2.54	0.09	1.04	1.02	0.02
Jun-22	2.67	2.61	0.06	0.89	0.87	0.02
Jul-22	2.15	2.07	0.08	0.72	0.69	0.03
Aug-22	2.03	1.97	0.05	0.70	0.65	0.04
Sep-22	2.00	1.94	0.06	0.65	0.69	-0.04
Oct-22	2.07	1.99	0.08	0.70	0.70	0.00
Nov-22	2.17	2.10	0.06	0.85	0.85	0.00
Dec-22	2.27	2.20	0.07	0.70	0.70	0.00
Jan-23	2.33	2.27	0.06	0.70	0.70	0.00
Feb-23	2.27	2.22	0.06	0.65	0.65	0.00
Mar-23	2.20	2.14	0.06	0.66	0.66	0.00
Apr-23	2.60	2.51	0.09	0.88	0.88	0.01
<b>ANNUAL TOTAL</b>	<b>27.39</b>	<b>26.56</b>	<b>0.83</b>	<b>9.15</b>	<b>9.05</b>	<b>0.10</b>
<b>T&amp; D Loss %</b>			<b>3.03 %</b>			<b>1.09 %</b>

**Table 42**

**Month wise and area wise T&D Loss curve for the year 2022-23**

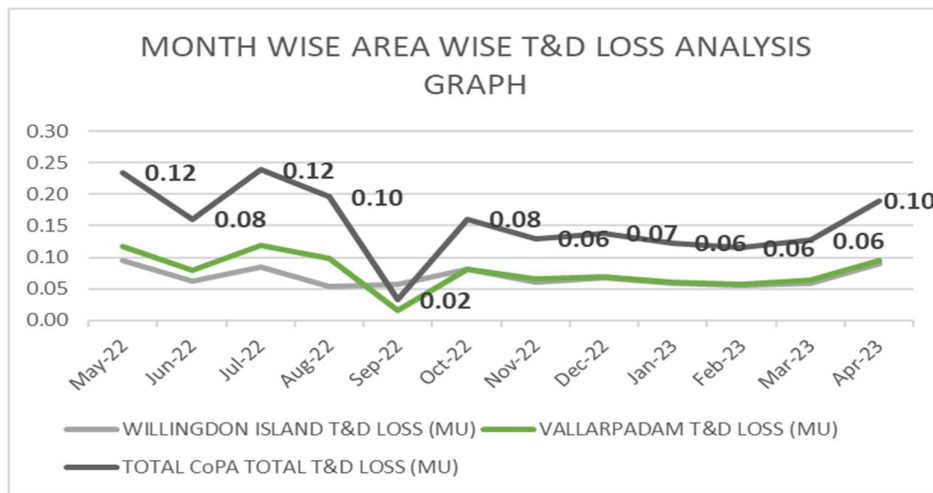

**Fig 10**

**8.7 POWER PURCHASE DETAILS**

CoPA imports Power from KSEBL through two locations as listed below.

**8.7.1 Power purchase details of the Willingdon Island**

<b>Consumer No: 1355410002636</b>							
<b>Contract demand :6500</b>							
	<b>MD Charges</b>			<b>Energy charges</b>			<b>Total charges</b>
<b>MONTH</b>	<b>Maximum demand</b>	<b>Rate /KV A</b>	<b>MD Charges</b>	<b>Consumption</b>	<b>Unit rate</b>	<b>Energy charges</b>	<b>Total charges</b>
May-22	6588	340	2239920	2604600	6.10	15888060	18152440
Jun-22	6578	340	2236520	2650350	6.10	16167135	18416915
Jul-22	4875	380	1852500	2130600	6.25	13316250	14684673
Aug-22	4875	380	1852500	2002950	6.25	12518437.5	14057977
Sep-22	4875	380	1852500	1973850	6.25	12335312.5	13880649
Oct-22	4875	380	1852500	2043300	6.25	12770625	14303859
Nov-22	4958	380	1884040	2134200	6.25	13338750	14890412
Dec-22	5040	380	1915200	2239350	6.25	13995937.5	15581412
Jan-23	4982	380	1893160	2301900	6.25	14386875	15920363
Feb-23	5772	380	219336	2242200	6.25	14013750	15856766
Mar-23	6024	380	2289120	2165250	6.25	13532812.5	15483612
Apr-23	6376	380	2422880	2565150	6.25	16032187.5	18054277
<b>Total</b>				<b>27053700</b>			

Table 43

## 8.7.2. Power Purchase details of Vallarpadam .

<b>Consumer No: 1355xxxxx3590</b>							
<b>Contract demand 3000</b>							
	<b>MD Charges</b>			<b>Energy charges</b>			
<b>MONT H</b>	<b>Maxim um demand</b>	<b>Rate KVA</b>	<b>MD Charges</b>	<b>Consump tion</b>	<b>Unit rate</b>	<b>Energy charges</b>	<b>Total charges</b>
May-22	2250	340	765000	1141850	6.10	6965285.0	7730285
Jun-22	2250	340	765000	816000	6.10	4977600.0	5970503
Jul-22	2250	380	855000	691700	6.25	4323125.0	7809011
Aug-22	2250	380	855000	695200	6.25	43451562.5	5264775
Sep-22	2250	380	855000	647640	6.25	4047750.0	4939848
Oct-22	2250	380	855000	703480	6.25	4396750.0	5163815
Nov-22	2250	380	855000	851320	6.25	5320750.0	6182250
Dec-22	2250	380	855000	698840	6.25	4367750.0	5429009
Jan-23	2250	380	855000	703120	6.25	4394500.0	5323994
Feb-23	2250	380	855000	648400	6.25	4052500.0	4991646
Mar-23	2250	380	855000	664000	6.25	4150000	5084665
Apr-23	2250	380	855000	882760	6.25	5517250	6432106
<b>Total</b>				<b>9144310</b>			

Table 44

## 8.8 . SINGLE LINE DIAGRAM OF THE DISTRIBUTION SYSTEM

### 1. SLD OF THE WILLINGDON ISLAND

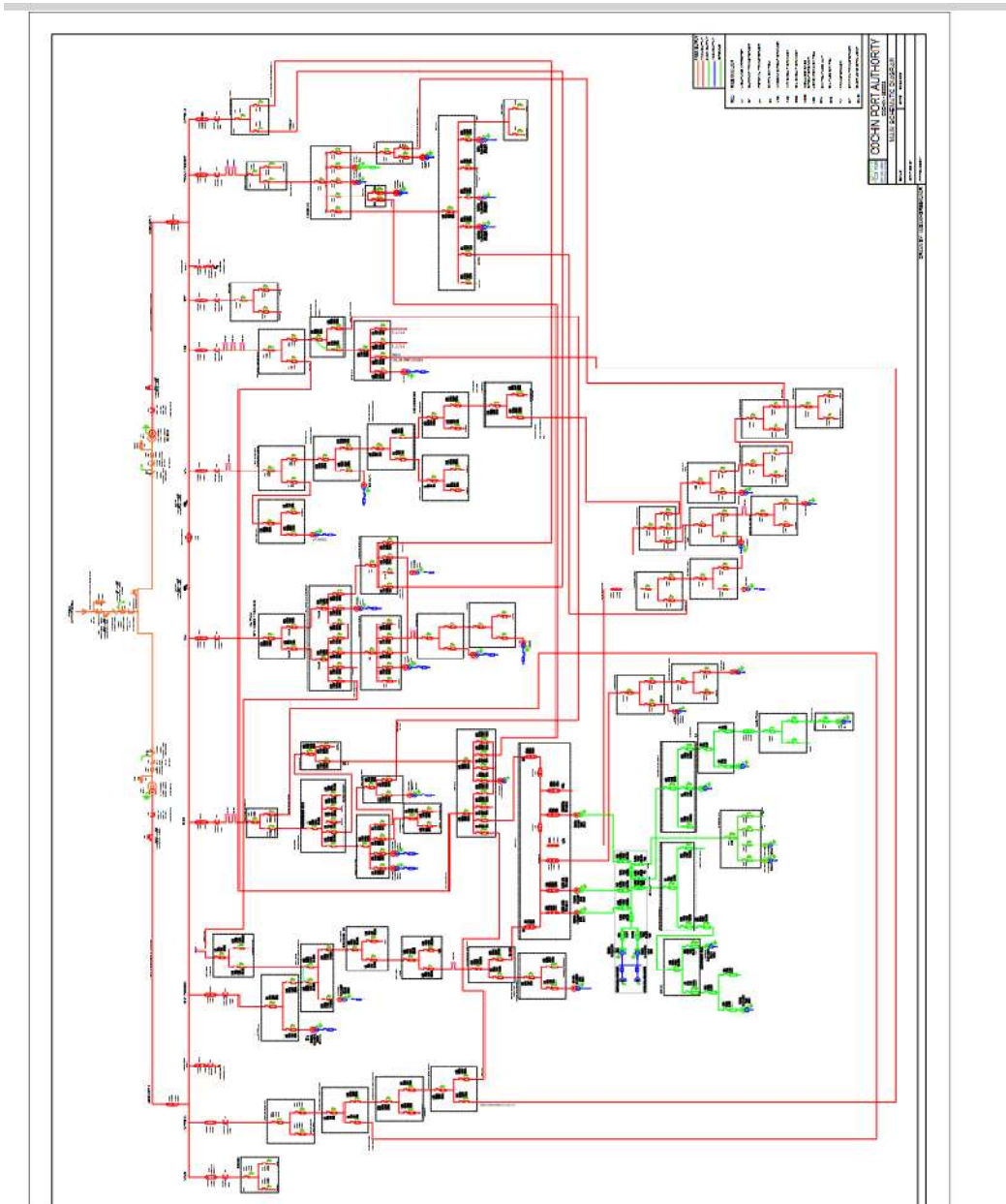

Fig 11

SINGLE LINE DIAGRAM OF THE -VALLAPADAM AREA

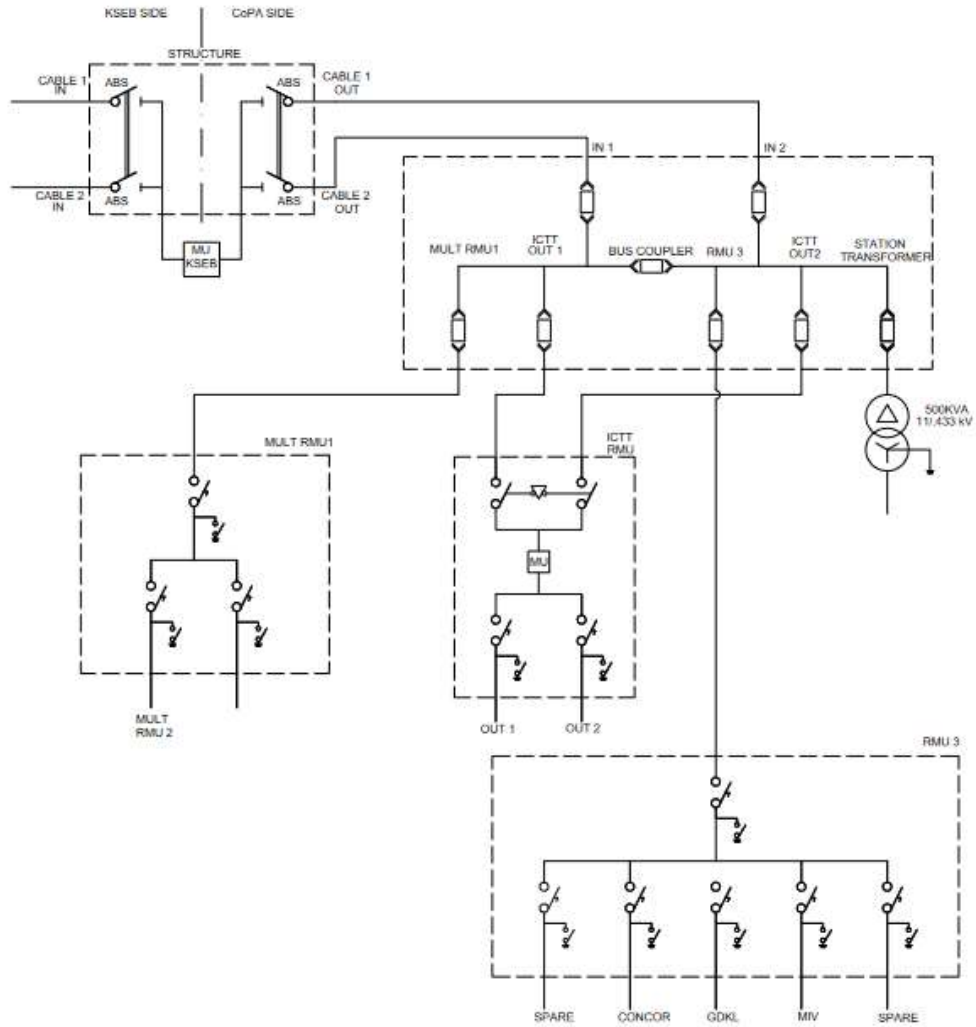

Fig 12

## 8.9 Category wise consumers and average billing rate

Period From 1st April 2022 to 31st March 2023								
Consumer profile			Energy parameters		Commercial Parameter			Average billing rate
Consumer category	Total Number of connections (Nos)	% of number of connections	Total energy	% of energy consumption	Billed Amount in Rs. Crore	Collected Amount in Rs. Crore	Collection Efficiency	
Residential	428	34%	0.926641	3%	0.602286	0.602286	100.00%	6.499671
Agricultural	0	0%	0	0%	0	0	0.00%	0
Commercial/Industrial-LT	582	46%	3.675433	10%	4.91468	4.91468	100.00%	13.3717
Commercial/Industrial-HT	29	2%	26.22357	74%	28.58328	28.58328	100.00%	10.89984
Others	217	17%	4.785379	13%	4.189846	4.189846	100.00%	8.755516
	<b>1256</b>	<b>100%</b>	<b>35.61103</b>	<b>100%</b>	<b>38.2901</b>	<b>38.2901</b>	<b>100.00%</b>	<b>10.75231</b>

Table 45

## 8.10 Category of service details (with consumer &amp; voltage wise )

	Parameters	66kV and above	33kV	11/22kV	LT
1	Number of conventional metered consumers	0	0	0	88
2.	Number of consumers with 'smart' meters	0	0	36	1132
3.	Number of consumers with 'smart prepaid' meters	0	0	0	0
4.	Number of consumers with 'AMR' meters	0	0	0	0
5.	Number of consumers with 'non-smart prepaid' meters	0	0	0	0
6.	Number of unmetered consumers	0	0	0	0
7.	Number of total consumers	0	0	36	1220

Table 46

**8.11 List of documents verified with each Parameters**

S.NO	List of Parameters verified	Reference documents /Criteria
1.	Broad system of the DISCOM	<ol style="list-style-type: none"> <li>1. Single line diagram of the Distribution system</li> <li>2. Site visit at incoming substations</li> <li>3. Overall visit of the Distribution area</li> </ol>
2.	DISCOM input energy for the FY 2022-23	<ol style="list-style-type: none"> <li>1. Energy account reports prepared by the Energy Manager of the DISCOM</li> <li>2. Power purchase bills from KSEBL for the year 2022-23</li> <li>3. Verification of the Solar energy input &amp; DG input from monthly report</li> </ol>
3.	DISCOM Category wise Sale of Energy	<ol style="list-style-type: none"> <li>1. SAP Report</li> <li>2. AMI software report</li> <li>3. Quarterly account report prepared by the Energy Manager of the DISCOM</li> </ol>
4.	T&D Loss	<ol style="list-style-type: none"> <li>1. Through calculation</li> <li>2. Energy account report prepared by the Energy Manager of the DISCOM.</li> </ol>
5.	Subsidy account	<ol style="list-style-type: none"> <li>1. Tariff petition filed by the DISCOM <b>No subsidy Payment from the Government to the CoPA.</b></li> </ol>
6.	Energy conservation measures implemented by the DISCOM and under implementations	<ol style="list-style-type: none"> <li>1. Previous Energy audit report for the Year 2021-22</li> <li>2. Report submitted by the DISCOM</li> </ol>
7.	Compliance of the reporting requirement	<ol style="list-style-type: none"> <li>1. Previous accounts report and audit reports submitted by the DISCOM</li> <li>2. Previous Energy audit report</li> <li>3. Website of the DISCOM</li> </ol>

**Table 47**



### **8.12 Brief Description of the Unit**

Since the CoPA is a small Licensee with hardly 1256 consumers under the Port area there is no Division, Sub Division or Section wise formation.

### **8.13 List of Parameters arrived through calculation**

There is no parameter arrived through calculation.

## **8.14 ENERGY AUDIT FORMATS**

**General information**

General Information			
1	Name of the DISCOM	Cochin Port Authority	
2	i) Year of Establishment	1936	
	ii) Government/Public/Private	Public	
3	DISCOM's Contact details & Address		
i	City/Town/Village	Cochin	
ii	District	Ernakulam	
iii	State	Kerala	Pin 682009
iv	Telephone	0484-2668200	Fax 0484-2666512
4	Registered Office		
i	Company's Chief Executive Name	Dr BEENA M, IAS	
ii	Designation	Chairman	
iii	Address	Cochin Port Authority, W.Island	
iv	City/Town/Village	Cochin	P.O. W.Island
v	District	Ernakulam	
vi	State	Kerala	Pin 682009
vii	Telephone	0484-2668566	Fax 0484-2666163
5	Nodal Officer Details*		
i	Nodal Officer Name (Designated at DISCOM's)	AJAYAKUMAR R.S	
ii	Designation	Executive Engineer(Ele)	
iii	Address	Cochin Port Authority, W.Island	
iv	City/Town/Village	Cochin	P.O. W. Island
v	District	Ernakulam	
vi	State	Kerala	Pin 682009
vii	Telephone	0484-2582350/2351	Fax 0484-2666639
6	Energy Manager Details*		
i	Name	Jayalakshmy.S	
ii	Designation	Asst. Exe. Engineer(Ele)	Whether EA or EM EM
iii	EA/EM Registration No.	Nil	
iv	Telephone	0484-2382360	Fax 0484-2666639
v	Mobile	9496450704	E-mail ID <a href="mailto:jayalakshmi@cochinport.gov.in">jayalakshmi@cochinport.gov.in</a>
7	Period of Information		
	Year of (FY) information including Date and Month (Start & End)	1st April 2022 to 31st March 2023	

## Performance summary of the DISCOM

Performance Summary of Electricity Distribution Companies			
<b>1</b>	Period of Information Year of (FY) information including Date and Month (Start & End)	1st April 2022 to 31st March 2023	
<b>2</b>	<b>Technical Details</b>		
<b>(a)</b>	<b>Energy Input Details</b>		
(i)	Input Energy Purchase (From Generation Source)	Million kwh	36.53
(ii)	Net input energy (at DISCOM Periphery after adjusting the transmission losses and energy traded)	Million kwh	36.53
(iii)	Total Energy billed (is the Net energy billed, adjusted for energy traded))	Million kwh	35.61
<b>(b)</b>	Transmission and Distribution (T&D) loss Details	Million kwh	0.92
		%	2.53
	Collection Efficiency	%	100%
<b>(c)</b>	Aggregate Technical & Commercial Loss	%	2.53%

I/We undertake that the information supplied in this Document and Pro-forma is accurate to the best of my knowledge and if any of the information supplied is found to be incorrect and such information result into loss to the Central Government or State Government or any of the authority under them or any other person affected, I/we undertake to indemnify such loss.

## Authorised Signatory and Seal

Name of A: Ajayakumar R.S  
Name of th Cochin Port Authority  
Full Addre W.Island, Cochin -682009, Kerala

Signature:-

Name of Energy Manager\*:

Registration Number:



Name of the Accredited auditor: J Nagesh Kumar

Registration Number: AEA 0133

Centre for Energy, Environment and Productivity  
Plot No. 1039, 26th Street, H-Block,  
Ponni Colony, Anna Nagar, Chennai - 600 040.  
PH : 044 2516 3483, 9444882553

Seal

**Form for Infrastructural details**

Form-Details of Input Infrastructure					
1	Parameters	Total	Covered during in audit	Verified by Auditor in Sample Check	Remarks (Source of total)
i	Number of circles	1		1	Through SFP
ii	Number of divisions				
iii	Number of sub-divisions				
iv	Number of feeders	15		11	4 Through AMI meter with
v	Number of DTs	30		30	0 No meter is installed
vi	Number of consumers	1256		1256	126 Through SFP
<b>2</b>	<b>Parameters</b>	<b>60kV and above</b>	<b>33kV</b>	<b>10/22kV</b>	<b>LT</b>
a.i	Number of conventional metered consumers	0	0	0	88
b	Number of consumers with 'smart' meters	0	0	56	1142
ii	Number of consumers with 'smart prepaid' meters	0	0	0	0
iv	Number of consumers with AMR meters	0	0	0	0
v	Number of consumers with 'non smart prepaid' meters	0	0	0	0
vi	Number of unmetered consumers	0	0	0	0
vii	<b>Number of total consumers</b>	<b>0</b>	<b>0</b>	<b>30</b>	<b>1220</b>
b.i	Number of conventionally metered Distribution Transformers	0			
i	Number of DTs with communicable meters	0	0	0	0
ii	Number of unmetered DTs	0	0	33	0
iv	<b>Number of total Transformers</b>	<b>0</b>	<b>0</b>	<b>33</b>	
c.i	Number of energized feeders	0	0	22	0
ii	Number of feeders with communicable meters	0	0	11	0
iv	Number of unmetered feeders	0	0	4	
v	<b>Number of total feeders</b>	<b>0</b>	<b>0</b>	<b>15</b>	
d	Line length (in km)		105		
e	Length of Aerial Bunched Cables		0		
f	Length of Underground Cables		85		
<b>3</b>	<b>Voltage level</b>	<b>Particulars</b>	<b>MU</b>	<b>Reference</b>	<b>Remarks (Source of total)</b>
i	60kV and above	Long-Term Conventional	27.054	Includes input energy for franchisees	From M/A KSEBL
		Medium Conventional	0		
		Short-Term Conventional	0		
		Banking	0		
		Long-Term Renewable energy	0		
		Medium and Short-Term RE	0	Includes power from bilateral/ PV/ DEEP	
		Captive, open access input	0	Any power wheeled for any purchase other than sale to DISCOM. Does not include input for franchisees.	
		Sale of surplus power	0.00%		
		Quantum of inter-state transmission loss	0	As confirmed by SUDC, PLDC etc	
		<b>Power procured from inter-state sources</b>	<b>0.0000</b>	Based on data from Form 2	
<b>Power at state transmission boundary</b>	<b>27.0537</b>				
ii	33kV	Long-Term Conventional	0		
		Medium Conventional	0		
		Short-Term Conventional	0		
		Banking	0		
		Long-Term Renewable energy	0		
		Medium and Short-Term RE	0		
		Captive, open access input	0		
		Sale of surplus power	0.00%		
		Quantum of intra-state transmission loss	0		
		<b>Power procured from intra-state sources</b>	<b>0</b>		
<b>Input in DISCOM wires network</b>	<b>0.00000</b>				
iii	33 kV	Renewable Energy Procurement	0		
		Small capacity conventional/ biomass/ hydro plants Procurement	0		
iv	11 kV	Captive, open access input	0.00000		
		Renewable Energy Procurement	0		
v	LT	Small capacity conventional/ biomass/ hydro plants Procurement	0		
		Sales Migration input	9.3443		
vi	LT	Renewable Energy Procurement	0.146034		
		Sales Migration input	0		
vii	LT	<b>Energy Embedded within DISCOM wires network</b>	<b>0</b>		
		<b>Total Energy Available/ Input</b>	<b>36.140340</b>		

ANNUAL ENERGY AUDIT REPORT OF COCHIN PORT AUTHORITY FOR THE YEAR 2022-23

4	Voltage level	Energy Sales Particulars	MU	Reference
i	LT Level	DISCOM' consumers	7.402	Include sales to consumers in franchisee areas, unmetered consumers
		Demand from open access, captive	0	Non DISCOM's sales
		Embedded generation used at LT level	0	Demand from embedded generation at LT level
		Sale at LT level	7.402	
		Quantum of LT level losses	**	Loss couldn't be assessed due to the absence of meters
		Energy input at LT level	**	Input to LT System couldn't be assessed due to absence of DTR Meters
ii	11 kV Level	DISCOM' consumers	28.209	Include sales to consumers in franchisee areas, unmetered consumers
		Demand from open access, captive	0	Non DISCOM's sales
		Embedded generation at 11 kV level used	0	Demand from embedded generation at 11kV level
		<b>Sales at 11 kV level</b>	28.209	
		Quantum of Losses at 11 kV	**	Loss couldn't be assessed due to the absence of meters
		Energy input at 11 kV level	36.198	
iii	33 kV Level	DISCOM' consumers	0	Include sales to consumers in franchisee areas, unmetered consumers
		Demand from open access, captive	0	Non DISCOM's sales
		Embedded generation at 33 kV or below level	0	This is DISCOM and OA demand met via energy generated at same voltage level
		<b>Sales at 33 kV level</b>	0	
		Quantum of Losses at 33 kV	0	
		Energy input at 33kV Level	0	
iv	> 33 kV	DISCOM' consumers		Include sales to consumers in franchisee areas, unmetered consumers
		Demand from open access, captive	0	Non DISCOM's sales
		Cross border sale of energy	0	
		Sale to other DISCOMs	0	
		Banking	0	
		Energy input at > 33kV Level	0	
		<b>Sales at 66kV and above (EHV)</b>	0	
<b>Total Energy Requirement</b>			<b>36.5340340</b>	
<b>Total Energy Sales</b>			<b>35.6110260</b>	

Energy Accounting Summary

5	DISCOM	Input (in MU)	Sale (in MU)	Loss (in MU)	Loss %
i	LT	8.3247830	7.401775	0.923008	**
ii	11 kV	36.19801	28.209251	0.000000	*
iii	33 kV	0	0		
iv	> 33 kV	27.054	0		
6	Open Access, Captive	Input (in MU)	Sale (in MU)	Loss (in MU)	
i	LT	0	0	0	
ii	11 kV	0	0	0	
iii	33 kV	0	0	0	
iv	> 33 kV	0	0	0	

\*\*Due to the absence of feeder meters and DTR meters it is unable to calculate the category wise losses of 11 kV Line and LT Line.

Loss Estimation for DISCOM	
T&D loss	0.92
D loss	0.92
T&D loss (%)	2.526433298
D loss (%)	2.526433298

Centre for Energy, Environment and Productivity  
 Plot No. 1039, 26th Street, H-Block,  
 Ponnai Colony, Anna Nagar, Chennai - 600 040.  
 PH : 044 2616 9483, 9444862553

ANNUAL ENERGY AUDIT REPORT OF COCHIN PORT AUTHORITY FOR THE YEAR 2022-23

Division wise Losses for the FY 2022-23

Details of Division Wise Losses (See note below**)																									
Division Wise Losses																									
S.No	Name of zone	Circle code	Name of Division	Consumer profile					Energy parameters					Losses			Commercial Parameter	AT & C Loss (%)							
				Consumer category	No of connection metered (Nos)	No of connection Un-metered (Nos)	Total Number of connections (Nos)	% of number of connections	Connected Load metered (MW)	Connected Load Un-metered (MW)	Total Connected Load (MW)	% of connected load	Input energy (MU)	Metered energy	Unmetered/assessment energy	Total energy			% of energy consumption	T&D loss (MU)	T&D loss (%)	Billed Amount In Ru. Crore	Collected Amount In Ru. Crore	Collection Efficiency (%)	
1		2	Willington Mission Valayada H	Residential	428	0	428	94%	0	0	0	0%	39.53403	0.928641	0.928641	0	0%	0.9230084	3%	0.9228813	0.9228813	100.00%			
				Agricultural	0	0	0	0%	0	0	0%	0		0	0	0%	0			0%	0	0%	0	0	0.00%
				Commercial/Industrial/IT	582	0	582	100%	0	0	0%	0		0	0	0%	0			0%	0	0%	0	0	0.00%
				Commercial/Industrial/MT	29	0	29	7%	0	0	0%	0		0	0	0%	0			0%	0	0%	0	0	0.00%
				Others	217	0	217	47%	0	0	0%	0		0	0	0%	0			0%	0	0%	0	0	0.00%
Sub-total				1236	0	1236	100%	0	0	0	100%	39.53403	9.826123	0	9.826123	100%	0.9230084	3%	9.826123	9.826123	100.00%	2%			
2				Residential	0	0	0	0%	0	0	0%	0	0	0	0	0%	0	0%	0	0	0.00%				
				Agricultural	0	0	0	0%	0	0	0%		0	0	0	0%			0	0%	0	0%	0	0	0.00%
				Commercial/Industrial/IT	0	0	0	0%	0	0	0%		0	0	0	0%			0	0%	0	0%	0	0	0.00%
				Commercial/Industrial/MT	0	0	0	0%	0	0	0%		0	0	0	0%			0	0%	0	0%	0	0	0.00%
				Others	0	0	0	0%	0	0	0%		0	0	0	0%			0	0%	0	0%	0	0	0.00%
Sub-total				0	0	0	100%	0	0	0	100%	0	0	0	0%	0	0%	0	0	0.00%	100%				
3				Residential	0	0	0	0%	0	0	0%	0	0	0	0	0%	0	0%	0	0	0.00%				
				Agricultural	0	0	0	0%	0	0	0%		0	0	0	0%			0	0%	0	0%	0	0	0.00%
				Commercial/Industrial/IT	0	0	0	0%	0	0	0%		0	0	0	0%			0	0%	0	0%	0	0	0.00%
				Commercial/Industrial/MT	0	0	0	0%	0	0	0%		0	0	0	0%			0	0%	0	0%	0	0	0.00%
				Others	0	0	0	0%	0	0	0%		0	0	0	0%			0	0%	0	0%	0	0	0.00%
Sub-total				0	0	0	100%	0	0	0	100%	0	0	0	0%	0	0%	0	0	0.00%	100%				
4				Residential	0	0	0	0%	0	0	0%	0	0	0	0	0%	0	0%	0	0	0.00%				
				Agricultural	0	0	0	0%	0	0	0%		0	0	0	0%			0	0%	0	0%	0	0	0.00%
				Commercial/Industrial/IT	0	0	0	0%	0	0	0%		0	0	0	0%			0	0%	0	0%	0	0	0.00%
				Commercial/Industrial/MT	0	0	0	0%	0	0	0%		0	0	0	0%			0	0%	0	0%	0	0	0.00%
				Others	0	0	0	0%	0	0	0%		0	0	0	0%			0	0%	0	0%	0	0	0.00%
Sub-total				0	0	0	100%	0	0	0	100%	0	0	0	0%	0	0%	0	0	0.00%	100%				
5				Residential	0	0	0	0%	0	0	0%	0	0	0	0	0%	0	0%	0	0	0.00%				
				Agricultural	0	0	0	0%	0	0	0%		0	0	0	0%			0	0%	0	0%	0	0	0.00%
				Commercial/Industrial/IT	0	0	0	0%	0	0	0%		0	0	0	0%			0	0%	0	0%	0	0	0.00%
				Commercial/Industrial/MT	0	0	0	0%	0	0	0%		0	0	0	0%			0	0%	0	0%	0	0	0.00%
				Others	0	0	0	0%	0	0	0%		0	0	0	0%			0	0%	0	0%	0	0	0.00%
Sub-total				0	0	0	100%	0	0	0	100%	0	0	0	0%	0	0%	0	0	0.00%	100%				
6				Residential	0	0	0	0%	0	0	0%	0	0	0	0	0%	0	0%	0	0	0.00%				
				Agricultural	0	0	0	0%	0	0	0%		0	0	0	0%			0	0%	0	0%	0	0	0.00%
				Commercial/Industrial/IT	0	0	0	0%	0	0	0%		0	0	0	0%			0	0%	0	0%	0	0	0.00%
				Commercial/Industrial/MT	0	0	0	0%	0	0	0%		0	0	0	0%			0	0%	0	0%	0	0	0.00%
				Others	0	0	0	0%	0	0	0%		0	0	0	0%			0	0%	0	0%	0	0	0.00%
Sub-total				0	0	0	100%	0	0	0	100%	0	0	0	0%	0	0%	0	0	0.00%	100%				
7				Residential	0	0	0	0%	0	0	0%	0	0	0	0	0%	0	0%	0	0	0.00%				
				Agricultural	0	0	0	0%	0	0	0%		0	0	0	0%			0	0%	0	0%	0	0	0.00%
				Commercial/Industrial/IT	0	0	0	0%	0	0	0%		0	0	0	0%			0	0%	0	0%	0	0	0.00%
				Commercial/Industrial/MT	0	0	0	0%	0	0	0%		0	0	0	0%			0	0%	0	0%	0	0	0.00%
				Others	0	0	0	0%	0	0	0%		0	0	0	0%			0	0%	0	0%	0	0	0.00%
Sub-total				0	0	0	100%	0	0	0	100%	0	0	0	0%	0	0%	0	0	0.00%	100%				
8				Residential	0	0	0	0%	0	0	0%	0	0	0	0	0%	0	0%	0	0	0.00%				
				Agricultural	0	0	0	0%	0	0	0%		0	0	0	0%			0	0%	0	0%	0	0	0.00%
				Commercial/Industrial/IT	0	0	0	0%	0	0	0%		0	0	0	0%			0	0%	0	0%	0	0	0.00%
				Commercial/Industrial/MT	0	0	0	0%	0	0	0%		0	0	0	0%			0	0%	0	0%	0	0	0.00%
				Others	0	0	0	0%	0	0	0%		0	0	0	0%			0	0%	0	0%	0	0	0.00%
Sub-total				0	0	0	100%	0	0	0	100%	0	0	0	0%	0	0%	0	0	0.00%	100%				
9				Residential	0	0	0	0%	0	0	0%	0	0	0	0	0%	0	0%	0	0	0.00%				
				Agricultural	0	0	0	0%	0	0	0%		0	0	0	0%			0	0%	0	0%	0	0	0.00%
				Commercial/Industrial/IT	0	0	0	0%	0	0	0%		0	0	0	0%			0	0%	0	0%	0	0	0.00%
				Commercial/Industrial/MT	0	0	0	0%	0	0	0%		0	0	0	0%			0	0%	0	0%	0	0	0.00%
				Others	0	0	0	0%	0	0	0%		0	0	0	0%			0	0%	0	0%	0	0	0.00%
Sub-total				0	0	0	100%	0	0	0	100%	0	0	0	0%	0	0%	0	0	0.00%	100%				
Sub-total				0	0	0	100%	0	0	0	100%	0	0	0	0%	0	0%	0	0	0.00%	100%				
70	Total			Residential	428	0	428	94%	0	0	0	0%	39.53403	0.928641	0.928641	0	0%	0.9230084	3%	0.9228813	0.9228813	100.00%			
				Agricultural	0	0	0	0%	0	0	0%	0		0	0	0%	0			0%	0	0	0.00%		
				Commercial/Industrial/IT	582	0	582	46%	0	0	0%	0		0	0	0%	0			0%	0	0	0.00%		
				Commercial/Industrial/MT	29	0	29	2%	0	0	0%	0		0	0	0%	0			0%	0	0	0.00%		
				Others	217	0	217	17%	0	0	0%	0		0	0	0%	0			0%	0	0	0.00%		
77	All company level			Residential	1236	0	1236	100%	0	0	0	100%	39.53403	9.826123	0	9.826123	100%	0.9230084	3%	9.826123	9.826123	100.00%	2%		

\*\* Note - It shall be mandatory to record the energy supplied separately for each category of consumers which is being provided a separate rate of subsidy in the tariff, by the state government, so that the subsidy due for the electricity distribution company is correctly calculated by multiplying the energy supplied to each of such category of consumers by the applicable rate of subsidy notified by the state government.

Code	Parameter
Y	Please enter name of circle
0	Please enter circle code
0	Please enter metered/ un-metered/ or
0	Formally protected

I/We undertake that the information supplied in this Document and Pro-forma is accurate to the best of my knowledge and if any of the information supplied is found to be incorrect and such information results into loss to the Central Government or State Government or any of the authority under them or any other person affected, I/we undertake to indemnify such loss.

Authorized Signatory and Seal: \_\_\_\_\_  
 Name of Authorized Signatory: \_\_\_\_\_  
 Name of the DISCOM: \_\_\_\_\_  
 Full Address: \_\_\_\_\_  
 Seal: \_\_\_\_\_

Signature: \_\_\_\_\_  
 Name of Energy Manager: \_\_\_\_\_  
 Registration Number: \_\_\_\_\_

Centre for Energy, Environment and Productivity  
 Plot No. 1050, 200 Street, 11 Block,  
 Pooni Colony, Anna Nagar, Chennai - 600 043.  
 Ph: 044 2616 5463, 9444822653  
 J. Rajan Kumar  
 Registration No: AEC 0223

ANNUAL ENERGY AUDIT REPORT OF COCHIN PORT AUTHORITY FOR THE YEAR 2022-23

Form of Input Energy

Form-input energy(Details of input energy & Infrastructure)			
A. Summary of energy input & Infrastructure			
S.No	Parameters		Remarks (Source of data)
A.1	Input Energy purchased (MU)	36.52403	From electricity Bill
A.2	Transmission loss (%)		
A.3	Transmission loss (MU)	0	
A.4	Energy sold outside the periphery(MU)	0	
A.5	Open access sale (MU)	0	
A.6	EHT sale	0	
A.7	Net input energy (received at DISCOM periphery or at distribution point)-(MU)	27.01	
A.8	Is 100% metering available at 66/33 kV (Select yes or no from list)	Yes	
A.9	Is 100% metering available at 11 kV (Select yes or no from list)	Yes	
A.10	% of metering available at DT	0%	
A.11	% of metering available at consumer end	100%	
A.12	No of feeders at 66kV voltage level	0	
A.13	No of feeders at 33kV voltage level	0	
A.14	No of feeders at 11kV voltage level	15	
A.15	No of LT feeders level	0	
A.16	Line length (ckt. km) at 66kV voltage level	0	
A.17	Line length (ckt. km) at 33kV voltage level	0	
A.18	Line length (ckt. km) at 11kV voltage level	85	
A.19	Line length (km) at LT level	155	
A.20	Length of Aerial Bunched Cables	0	
A.21	Length of Underground Cables	155	
A.22	HT/LT ratio	01:01.8	

B. Meter reading of input energy at injection points																					
S.No	Zone	Circle	Voltage Level (KV)	Division (KVA)	Sub-Division (KVA)	Feeder ID	Feeder Name	Feeder Metering Status (Metered/unmetered) / AMI/AMR	Status of Meter (Functional/Non-Functional)	Metering Date of last actual meter reading / communication	Feeder Type (Agri/Industrial/Mixed)	Status of Communication			Period from...to...				Sales	Remarks (Source of data)	
												% data receive d through h automatical ly if feeder AMR	Number of hours when meter was unable to communicate	Total Number of hours in the period	Meter S.No	CT/PT ratio	Import (MU)	Export (MU)			
B.1			110/11	9500	6500/3000	K01A	MNC	AMI	Functional		Mixed	1	0		0440888	100%			0.30		
B.2						K36	NTR0 KV	AMR	Functional		Mixed	1	0		0440888	100%			2.50		
B.3						3	Q9 1	AMI	Functional		Mixed	1	0		0440888	100%			6.69		
B.4						4	Q92	AMI	Functional		Mixed	1	0		0440888	100%			4.40		
B.5						5	MH2	AMI	Functional		Mixed	1	0		0440888	100%			2.45		
B.6						9	UTL	AMI	Functional		Mixed	1	0		0440888	100%			2.59		
B.7						30	Q93	AMI	Functional		Mixed	1	0		0440888	100%			2.30		
B.8						11	MH3	AMI	Functional		Mixed	1	0		0440888	100%			0.00		
B.9						12	STR TR	AMR	Functional		Mixed	1	0		0440888	100%			0.08		
B.10						K35	PNNA	AMI	Functional		Mixed	1	0		0440888	100%			4.80		
B.11						K17	NTR0 A2	AMI	Functional		Mixed	1	0		0440888	100%			0.91		
B.12							Others														
B.13																					
B.14																					
B.15																					
B.1307																					
B.1390																					
B.1391																					
B.1392																					
B.1393																					
B.1394																					
B.1395																					
B.1396																					
B.1397																					
B.1398																					
B.1399																					
B.1400																					
B.1001	Total (MU)															0.00	27.01				
B.1002	Net input energy at DISCOM periphery (MU)																	0.00	27.01	-27.01	

Color code	Parameter
	Please enter voltage level or leave blank
	Please enter feeder id and name or leave blank
	Enter meter no or leave blank
	Enter CT/PT ratio or leave blank
0	Please enter numeric value or 0
	Please select yes or no from list
	Formula protected

We undertake that the information supplied in this Document and Pro-forma is accurate to the best of my knowledge and if any of the information supplied is found to be incorrect and such information result into loss to the Central government or State Government or any of the authority under them or any other person affected, I/we undertake to indemnify such loss.

Authorized Signatory and Seal

Signature of Authorized Signatory

Centre for Energy, Environment and Productivity  
 Plot No. 1036, 26th Street, 14-Block,  
 Ponnambally, Anna Nagar, Chennai - 600 040.  
 PH : 044 2616 3463, 9444832553

  
**J Nagesh Kumar**  
 Accredited Energy Auditor  
 Registration No: AEA 0133

Signature:  
 Name of Energy Manager:  
 Registration Number:





ANNUAL ENERGY AUDIT REPORT OF COCHIN PORT AUTHORITY FOR THE YEAR 2022-23

Details on Feeder level

(Details of Feeder-wise losses)																	
Period From 1st April 2022 to 31st March 2023																	
Sl No.	Zone	Received at Circle (In MU)	Received at Division (In MU)	Received at Sub-Station (In MU)	Name of the Station	Feeder Code/ID	Feeder Name	Type of Feeder (Urban/Road/Industrial/Agricultural/Rural)	Type of Feeder meter (AM/AMR/Other)	Received at Feeder (Final In MU)	Feeder Consumption (In MU)	Final Net Export at Feeder Level (In MU)	T&D losses	AT&C losses	% Data Received through Automatically (If Feeder AMR/AM)	Remarks	
1		0.20	NA	NA	110 KV Wellington Island	K01 A	MWC	Urban	AM	0.20	Not recorded	0					
2		7.50	NA	NA	110 KV Wellington Island	K16	STRG KV	Urban	AM	7.50	Not recorded	0					
3		6.00	NA	NA	110 KV Wellington Island	3	(01)	Urban	AM	6.00	Not recorded	0					
4		4.40	NA	NA	110 KV Wellington Island	4	ODD	Urban	AM	4.40	Not recorded	0					
5		2.45	NA	NA	110 KV Wellington Island	5	AMC2	Urban	AM	2.45	Not recorded	0					
6		2.59	NA	NA	110 KV Wellington Island	9	ULI	Urban	AM	2.59	Not recorded	0					
7		2.40	NA	NA	110 KV Wellington Island	10	UDS	Urban	AM	2.40	Not recorded	0					
8		0.00	NA	NA	110 KV Wellington Island	11	AMC3	Urban	AM	0.00	Not recorded	0					
9		0.00	NA	NA	110 KV Wellington Island	13	STN TB	Urban	AM	0.00	Not recorded	0					
10		4.80	NA	NA	110 KV Wellington Island	K15	PONAL	Urban	AM	4.80	Not recorded	0					
11		0.91	NA	NA	110 KV Wellington Island	K17	STRG A2	Urban	AM	0.91	Not recorded	0					
12					Vallarpadam 11 KV Substation		MULTI RMU NO.1	Urban									
13					Vallarpadam 11 KV Substation		K11	Urban									
14					Vallarpadam 11 KV Substation		STN TB	Urban									
15					Vallarpadam 11 KV Substation		RMU NO.3	Urban									

Feeder wise losses could not be calculated since the distribution network is in ring main system. Moreover no DTM Meters and Border meters.

Details on DT Wise losses

(Details of DT wise losses)															
Period From 1st April 2022 to 31st March 2023															
Sl No.	Sub-station ID	Feeder ID	Feeder Name	DT Id no.	DT Capacity (kVA)	Predominant consumer type of DT (Domestic/Industrial/Agriculture/Mixed)	Type of metering (Unmetered/AM/AMR/Other)	Status of meter (functional/non-functional)	% of data received automatically (If AM/AMR)	No. of connected consumers	Input Energy (MU)	Billed Energy (MU)	Loss of Energy (MU)	% Loss	Remarks
1	110 KV Substation	K01 A	MWC	1	1					0	4	0	30* (24.0)	17% (15.0)	DTM Meters not installed.
2	110 KV Substation	K16	STRG KV								0.20				
3	110 KV Substation	3	(01)								7.50				
4	110 KV Substation	4	ODD								6.00				
5	110 KV Substation	5	AMC2								4.40				
6	110 KV Substation	9	ULI								2.45				
7	110 KV Substation	10	UDS								2.59				
8	110 KV Substation	11	AMC3								2.40				
9	110 KV Substation	13	STN TB								0.00				
10	110 KV Substation	K15	PONAL								0.00				
11	110 KV Substation	K17	STRG A2								4.80				
12	Vallarpadam 11 KV Substation		MULTI RMU NO.1								0.91				
13	Vallarpadam 11 KV Substation		K11								0.00				
14	Vallarpadam 11 KV Substation		STN TB												
15	Vallarpadam 11 KV Substation		RMU NO.3												

*J. M. ...*  
 Centre for Energy, Environment and Productivity  
 Plot No. 1039, 26th Street, H-Block,  
 Ponnai Colony, Anna Nagar, Chennai - 600 040.  
 PH : 044 2616 3483, 9444882553

ANNUAL ENERGY AUDIT REPORT OF COCHIN PORT AUTHORITY FOR THE YEAR 2022-23

Details of consumer category wise subsidy billed/received

B.Details of Consumer Category-wise Subsidy Billed/Received														
Period from April 2022 to March 2023(not applicable)														
Consumer Category (Separate for each subsidized consumer category)	Billed Energy (MU)			Subsidized Billed Energy			Applicable rate of Subsidy as notified by State govt.		Subsidy Due from State Govt.			Subsidy Actually Billed / claimed from State Govt. (As against col.12)	Subsidy Received from State Govt. (As against col.12)	Balance Subsidy yet to be Received from State Govt.
	Metered	Un-metered*	Total	Metered (out of col.2)	Un-metered* (out of col.2)	Total	Metered Energy**	Un-metered Energy**	Metered Energy	Un-metered Energy	Total	(In Rs. Cr.)	(In Rs. Cr.)	(In Rs. Cr.)
	(In kWh)		4*2+3	(In kWh)		7*5+6	(In Rs./kWh)		(In Rs. Cr.)		12*10+11	13	14	15*13-14
Residential	0.00	0.00	0.00	There is no subsidy payment to CoPA by the Government										
Agricultural	0.00	0.00	0.00	There is no subsidy payment to CoPA by the Government										
Commercial/Industrial-LT	3.08	0.00	3.08	There is no subsidy payment to CoPA by the Government										
Commercial/Industrial-HT	26.22	0.00	26.22	There is no subsidy payment to CoPA by the Government										
Other (Specify)	4.79	0.00	4.79	There is no subsidy payment to CoPA by the Government										
<b>Total</b>	<b>35.01</b>	<b>0.00</b>	<b>35.01</b>											

Centre for Energy, Environment and Productivity  
 Plot No. 1039, 26th Street, H-Block,  
 Ponni Colony, Anna Nagar, Chennai - 600 040.  
 PH : 044 2616 3463, 9444882553

8.15 Energy Purchase bill for the supply of Energy at Vallarpadam (Feb 20230-Supplier KSEBL.

**KERALA STATE ELECTRICITY BOARD LIMITED**

Office of the Special Officer(Revenue), Pattom,Thiruvananthapuram

**DEMAND NOTICE FOR FEBRUARY 2023**

(As per CHAPTER VII OF KERALA ELECTRICITY SUPPLY CODE -2014)

Con	135565004530	Bill Date	02-Feb-2023	Due Date	02-Feb-2023	Bill No	21028111041099 Ver : 0							
Tariff	Licensee: CPT	DC Date	24-Feb-2023	CD		5116050	5116050							
COCHIN PORT TRUST-VALLARPADAM JOINT DIRECTOR,PORT BASED SEZ, COCHIN PORT TRUST,VALLARPADAM, ERNAKULAM,,COCHIN- 9 Mobile no-9446448101				SBI Virtual A/c No(IFS Code:SBIN0070493)-KSEBHT5C5403 Consumer GSTIN_ID :KSEB ILIGST ID=32AAECK2277NBZ1 TDS uia 194Q : 4991.65										
LCN :6/6403				SBI Virtual A/c No(IFS Code:SBIN0070493)-KSEBHT5C5403										
Amounts as on 31-Dec-2022				Date of Previous Reading		31-Dec-2022								
Disputed				Date of Present Reading		31-Jan-2023								
Undisputed				Supply Voltage		11 kV HT								
12614403				Billing Type		Non-OPS								
Contract Demand(KVA)				Average MD (kVA)		Consumption (kWh)								
75% of CD (KVA)				2074.00		886300								
150% of CD (KVA)				3000.0		0.99								
Connected Load (KW)				Circle		Ernakulam								
3000.0				2250.0		3900.0								
610														
Reading Details of meter 22001331-Working (KVA,KWh,KVAh & KVArh) for 01-2023														
1. Energy Consumption(KWh)				3. Energy Consumption(KVArh) Lag and										
Zone	FR	IR	MF	Units	Zone	FR	IR	MF	Units	FR	IR	Units		
1	43776.00	37739.00	40.000	241480	1	3497.00	3005.00	40.000	19880	1284.00	1048.00	8940		
2	21877.00	18420.00	40.000	138280	2	1166.00	886.00	40.000	7200	362.00	294.00	2720		
3	41058.00	34340.00	40.000	268940	3	2058.00	1684.00	40.000	15760	1039.00	880.00	8380		
Total				648400	Total KVArh(Lag)				42640	KVArh(Lead)				17720
2. Energy Consumption(KVAh)				4. Demand (KVA)										
Zone	FR	IR	MF	Units	1		Readings	MF	Units					
1	44458.00	38319.00	40.000	245960	2		30.97	40.000	1238.8					
2	21983.00	18508.00	40.000	139000	3		38.53	40.000	1541.2					
3	41278.00	34517.00	40.000	270440			38.38	40.000	1534.4					
Total				855000	5.Factory Lighting								0.0	
Avg.PF=KWh/KVAh				0.99	6.Colony Lighting								0.0	
					7.Generator								0	
INVOICE														
1.Total Demand Charge				9.Other Charges										
a. Demand Charge	2250.00	380.000	855000.00	Reconnection Fee				0.00						
b.	0.00	380.000	0.00	Charges for Selected Payments				16198.00						
c.	0.00	380.000	0.00											
d. Excess Demand Charge	0.00	190.000	0.00											
e.	0.00	190.000	0.00											
f.	0.00	190.000	0.00											
Sub total (a+b+c+d+e+f)				855000.00										
2.Total Energy Charges														
a. Energy charges	648400	6.25000	4052500.00											
b.	0.00	9.37500	0.00											
c.	0.00	4.68750	0.00											
Sub total(a+b+c)				4052500.00										
S.P.F Incentive / Discardrive				-81050.00										
Total Energy Charge				3971450.00										
4.Energy Charges on Lighting load														
a.Factory Lighting	0	0.2		10.(a+b)(add 1 to 9)				4921546.00						
b.Colony Lighting	0	0.2	0.00	Plus/Minus (Round off)				0.00						
Sub total(a+b)				0.00				12614403.00						
5.Electricity Duty				4052500				L499						
6.Elc. Surcharge				648400				1. Advance / Credit						
7.Duty on self generated energy				0				2. CD Interest						
B.Penalty for non-segn. of light load				0				3. CD/DBs Ref						
								Net Payable						
								17606045.00						
(Rupees One Crore Seventy Six Lakh Six Thousand Forty Nine Only)														
E & O.E								Balance Advance at Credit, if any						
As per Regulation 130 of Kerala Electricity Supply Code 2014 any complaint regarding accuracy of a bill shall be first taken up with the officer designated to issue the bill (Special Officer(Revenue)). Please follow our official Facebook page fb.com/ksebl for information & announcements.(Please see the instructions overleaf).														
								SPECIAL OFFICER (REVENUE)						
135565004530								21028111041099						
COCHIN PORT TRUST-VALLARPADAM								Rs. 17606045.00						
DD/Payment Instruction								Name of the						
								Date						
								February 2023						

8.16 Energy purchase bill for the Willingdon Island (April 2023)-Su

KERALA STATE ELECTRICITY BOARD LIMITED														
Office of the Special Officer (Revenue), Palloor, Thiruvananthapuram														
DEMAND NOTICE FOR APRIL 2023														
(As per CHAPTER VI of KERALA ELECTRICITY SUPPLY CODE -2014)														
Sl. No.	1022/1802500	Bill Date	05-Apr-2023	Due Date	02-Apr-2023	Bill No.	11022/1100/1204 Vol : B							
Tariff	License: CPT	DD Date	27-Apr-2023	CD		10004800 (SU)	10002000							
<b>COCHIN PORT TRUST</b> Office to the Executive Engineer (Ele.), I.G.Road, Cochin-3, Indragandhi Road, Cochin-3, Ernakulam 682003, Mobile no-9847078217 LCN :21/1135						SBI Virtual A/c No.(IFS Code:SBIN0070493)-KSEBHT21C1135 Consumer GSTN ID -KSEB (L)GST ID:32AAECK0277NEZ TDS via 194Q - 18054.38								
Arrests as on 26-Feb-2023				Date of Previous Reading		26-Feb-2023		Email: dyc2rselek@cochinport.gov.in						
Disputed		Undisputed		Date of Present Reading		21-Mar-2023		Supply Voltage : 110 KV - HT						
Contract Demand(KVA)		75% of CD (KVA)	100% of CD (KVA)	Connected Load (KW)		Average		Billing Type		Non-DPS				
8900.0		4875.0	8450.0	0		8900.20		2440000		0.00				
MD (KVA)		Consumption (KWH)		PF		Section		110 KV Sub Station						
						Circle		Transmission Circle						
Reading Details of meter 17078922-Working (KVA,KWh,KVAh & KVArh) for 03-2023														
1. Energy Consumption(KWh)						2. Energy Consumption(KVArh) Lag and KVArh (Lead)								
Zone	RR	IR	MP	Units		Zone	RR	IR	MP	Units	MP	IR	Units	
1	543926.00	542046.00	150.000	5207000		1	87254.0	89713.0	150.000	527000	779.00	742.30	5850	
2	161890.00	162090.00	150.000	430300		2	30743.0	28845.0	150.000	327000	56.00	25.00	450	
3	262800.00	262800.00	150.000	722600		3	81760.0	81538.0	150.000	369000	807.00	794.30	4860	
				Total	2990700					Total KVArh(Lag)	210000		KVArh(Lead)	10000
3. Energy Consumption(KVAh)						4. Demand (KVA)								
Zone	RR	IR	MP	Units		1		Readings	MP	Units				
1	543926.00	542046.00	150.000	5470000		2		42.300	150.000		8375.0			
2	161890.00	162090.00	150.000	430000		3		30.350	150.000		4962.80			
3	262800.00	262800.00	150.000	724000				27.800	150.000		4170.75			
				Total	2990700									
Avg PF-KVAh/KVA				1.00										
INVOICE														
		Units	Rate	Amount (Rs)			Amount							
1. Total Demand Charge						5. Other Charges								
a. Demand Charge				6076.0	380.000	2307680.00	Reconnection Fee	0.00						
b.				0.0	380.000	0.00	Charges for Delayed Payments	14.00						
c.				0.0	380.000	0.00								
d. Excess Demand Charge				0	180.000	0.00								
e.					120.000	0.00								
f.					180.000	0.00								
Sub Total (a-b-c-d-e-f)					2422000.00									
2. Total Energy Charges														
a. Energy charges				2565150	8.25000	2102187.50								
b.					8.37500	0.00								
c.					4.68750	0.00								
Sub Total(a+b+c)					16022107.50									
3. PF Incentive / Disincentive														
Total Energy Charge														
4. Energy Charges on Lighting load														
a. Factory Lighting				0	0.1		10. Total (add 1 to 9)		18054270.00					
b. Colony Lighting				0	0.1	0.00	Plus/Minus (Rounded off)		0.10					
Sub Total(a+b)							Less/Disputed Amt Amount							
5. Electricity Duty				18022100	0.100		Less 1. Advance / Credit							
6. Ele. Surcharge				8583150	0.000		2. CD Incent		0.00					
7. Duty on self-generated energy				0	0.012	0.00	3. CD Dth Ref		0.00					
8. Penalty for non-usage of light load							Net Payable		18054277.00					
(Repeat One Crore Eighty Lakh Fifty Four Thousand Two Hundred Seventy Seven Only)														
F & Q F				Balance Advance or Credit, if any										
As per Regulation 130 of Kerala Electricity Supply Code 2014 any complaint regarding accuracy of a bill shall be first taken up with the officer designated to issue the bill (Special Officer (Revenue)). Please follow our official Facebook page fb.com/ksebi for information & announcements. (Please see the instructions overleaf)														
SPECIAL OFFICER (REVENUE)														
Name of the consumer and bill No														
1125/11002032		11022/1100/104		Rs. 18054277.00		April 2023								
COCHIN PORT TRUST														
DD/Payment Instructions <input type="text"/> Name of the <input type="text"/> Date <input type="text"/>														

## 8.17 Peak load measurement details of Transformers

	Transformer name	Capacity	Full load A	Date of test	Peak Load (A)			Voltage			% Loading	Unbalance between Phases
					R Ph	Y ph	Bph	R-Y	Y-B	R-B		
1	Feeder Transformer	250	333.25	13-07-2023	11.74	16.3	11.34	415	415	412	4.89	3.41
2	West Way	250	333.35	13-07-2023	15.5	14.4	1.94	414	417	416	4.32	87.48
3	Tropicana	315	420	13-07-2023	12.1	13.1	0.9	417	419	416	3.12	92.56
4	Konkan	630	840.05	13-07-2023	22	25.3	51.5	415	418	418	3.01	-134.09
5	SBI	500	666.7	13-07-2023	102	125.7	95.51	415			18.85	6.36

Table 48

8.18 Photos of functional feeder meters installed in Willingdon substation



Feeder Name: Q9-2

Fig 13



Feeder Name UTL

Fig 14



**Feeder Name: Q9-1**

**Fig 15**



**Feeder Name: NTRO A2**

**Fig 16**



**8.19 FEEDER METER READINGS DOWNLOADED FROM AMI SOFTWARE****1. FEEDER NAME : Q9-1**

RTC	MeterNo	KWH_Import	KWH_Export	KVAH_Import	MD_KW	MD_kVA	KVAR
13-07-2023 23:39	GP4409885	551388.1	0	566718.8	35.6	36.5	2.84
13-07-2023 22:37	GP4409885	551375.3	0	566705.5	35.6	36.5	2.52
13-07-2023 21:40	GP4409885	551362.9	0	566692.9	35.6	36.5	2.9
13-07-2023 20:35	GP4409885	551347.5	0	566677.1	35.6	36.5	3.74
13-07-2023 19:45	GP4409885	551335	0	566664.1	35.6	36.5	4.02
13-07-2023 18:35	GP4409885	551316.5	0	566644.9	35.6	36.5	4.72
13-07-2023 17:43	GP4409885	551301	0	566629.1	35.6	36.5	5.01
13-07-2023 16:52	GP4409885	551281.3	0	566608.8	35.6	36.5	6.26
13-07-2023 15:42	GP4409885	551248.9	0	566575.3	35.6	36.5	8.03
13-07-2023 14:41	GP4409885	551219.1	0	566544.5	35.6	36.5	7.25
13-07-2023 13:47	GP4409885	551193	0	566517.4	35.6	36.5	7.29
13-07-2023 12:42	GP4409885	551162.2	0	566485.4	35.6	36.5	8.86
13-07-2023 11:38	GP4409885	551130.1	0	566452.3	35.6	36.5	7.27
13-07-2023 10:41	GP4409885	551100.9	0	566422.1	35.6	36.5	6.48
13-07-2023 09:40	GP4409885	551071.4	0	566391.4	35.6	36.5	7.72
13-07-2023 08:40	GP4409885	551050.9	0	566370.4	35.6	36.5	2.8
13-07-2023 07:36	GP4409885	551036.7	0	566355.8	35.6	36.5	2.9
13-07-2023 06:36	GP4409885	551025.3	0	566344.2	35.6	36.5	1.71

**2. FEEDER NAME : Q9-2**

RTC	MeterNo	KWH_Import	KWH_Export	KVAH_Import	MD_KW	MD_kVA	KVAR	Current_IR	Current_IY	Current_IB	Voltage_VR
13-07-2023 09:40	GP4409882	394589.7	0	397878.1	23.8	24	-1.63	0.9	0.96	0.83	6229
13-07-2023 08:40	GP4409882	394573.2	0	397861.5	23.8	24	-2.29	0.82	0.85	0.72	6216
13-07-2023 07:36	GP4409882	394558.7	0	397846.8	23.8	24	-2.53	0.67	0.72	0.6	6192
13-07-2023 06:36	GP4409882	394546.5	0	397834.5	23.8	24	-1.94	0.78	0.82	0.68	6199
13-07-2023 05:40	GP4409882	394535.4	0	397823.1	23.8	24	-2.11	0.65	0.69	0.54	6250
13-07-2023 04:37	GP4409882	394524.2	0	397811.6	23.8	24	-2.57	0.51	0.52	0.5	6324
13-07-2023 03:38	GP4409882	394513.5	0	397800.7	23.8	24	-1.85	0.74	0.78	0.63	6326
13-07-2023 02:45	GP4409882	394505.2	0	397792.2	23.8	24	-2.1	0.62	0.63	0.53	6297
13-07-2023 01:41	GP4409882	394493.2	0	397779.9	23.8	24	-3.06	0.55	0.56	0.54	6327
13-07-2023 00:43	GP4409882	394482	0	397768.4	23.8	24	-1.69	0.71	0.74	0.63	6325

**3. FEEDER NAME : UTL**

RTC	MeterNo	KWH_Import	KWH_Export	KVAH_Import	MD_KW	MD_kVA	KVAR
13-07-2023 23:39	GP4409899	37165.65	0	40465	30.8	31.5	1.09
13-07-2023 22:37	GP4409899	37163.35	0	40462.35	30.8	31.5	1.37
13-07-2023 21:40	GP4409899	37162.1	0	40460.8	30.8	31.5	0.99
13-07-2023 20:35	GP4409899	37160	0	40458.3	30.8	31.5	1.07
13-07-2023 19:45	GP4409899	37157.5	0	40455.65	30.8	31.5	0.86
13-07-2023 18:41	GP4409899	37154.8	0	40452.7	30.8	31.5	1.1
13-07-2023 17:43	GP4409899	37150.3	0	40447.75	30.8	31.5	1.27
13-07-2023 16:39	GP4409899	37142.4	0	40439.6	30.8	31.5	1.04
13-07-2023 15:42	GP4409899	37132.75	0	40429.45	30.8	31.5	-1
13-07-2023 14:41	GP4409899	37118.2	0	40414.15	30.8	31.5	-3.25
13-07-2023 13:41	GP4409899	37105.25	0	40400.55	30.8	31.5	1.03
13-07-2023 12:42	GP4409899	37091.3	0	40385.95	30.8	31.5	-0.76
13-07-2023 11:38	GP4409899	37073.65	0	40367.45	30.8	31.5	0.97
13-07-2023 10:41	GP4409899	37048.65	0	40341.95	30.8	31.5	2.6
13-07-2023 09:41	GP4409899	37035.65	0	40328.4	30.8	31.5	-3.57
13-07-2023 08:40	GP4409899	37030	0	40322.5	30.8	31.5	-4.48
13-07-2023 07:36	GP4409899	37025.95	0	40317.7	30.8	31.5	1.85
13-07-2023 06:36	GP4409899	37021.8	0	40313.05	30.8	31.5	1.84

**4. FEEDER NAME: NTRO A2**

RTC	MeterNo	KWH_Import	KWH_Export	KVAH_Import	MD_KW	MD_kVA	KVAR	Current_IR	Current_IY	Current_IB
14-07-2023 03:49	GP4409883	315296.9	0	319522.5	16.1	16.2	-0.74	-0.32	-0.29	-0.29
14-07-2023 02:42	GP4409883	315292.1	0	319517.4	16.1	16.2	-1.06	-0.24	-0.21	-0.22
14-07-2023 01:39	GP4409883	315287.3	0	319512.5	16.1	16.2	-0.81	-0.3	-0.26	-0.27
14-07-2023 00:39	GP4409883	315282.1	0	319507.4	16.1	16.2	-0.68	-0.3	-0.27	-0.27
13-07-2023 23:39	GP4409883	315277	0	319502.2	16.1	16.2	-0.61	-0.3	-0.27	-0.27
13-07-2023 22:37	GP4409883	315271.6	0	319496.9	16.1	16.2	-0.85	-0.31	-0.27	-0.28
13-07-2023 21:45	GP4409883	315267.3	0	319492.4	16.1	16.2	-0.74	-0.32	-0.28	-0.29
13-07-2023 19:55	GP4409883	315257.9	0	319482.9	16.1	16.2	-0.66	-0.35	-0.3	-0.32
13-07-2023 18:00	GP4409883	315247.4	0	319472.3	16.1	16.2	-0.41	-0.3	-0.27	-0.26
13-07-2023 15:42	GP4409883	315231	0	319455.9	16.1	16.2	-0.54	-0.67	-0.64	-0.6
13-07-2023 14:41	GP4409883	315223	0	319447.9	16.1	16.2	-1.01	-0.32	-0.3	-0.28
13-07-2023 12:56	GP4409883	315213.7	0	319438.4	16.1	16.2	-0.98	-0.31	-0.28	-0.29
13-07-2023 10:41	GP4409883	315191.9	0	319416.5	16.1	16.2	-0.04	-0.63	-0.59	-0.56
13-07-2023 09:40	GP4409883	315181.6	0	319406.1	16.1	16.2	-0.32	-0.59	-0.57	-0.51
13-07-2023 08:40	GP4409883	315173.7	0	319398.1	16.1	16.2	-0.64	-0.31	-0.28	-0.29
13-07-2023 06:48	GP4409883	315164.5	0	319389	16.1	16.2	-0.88	-0.28	-0.25	-0.26
13-07-2023 05:45	GP4409883	315158.8	0	319383.3	16.1	16.2	-0.54	-0.4	-0.36	-0.35
13-07-2023 04:37	GP4409883	315151	0	319375.4	16.1	16.2	-0.41	-0.41	-0.37	-0.36
13-07-2023 03:38	GP4409883	315143.9	0	319368.3	16.1	16.2	-0.44	-0.39	-0.35	-0.35
13-07-2023 02:45	GP4409883	315138.1	0	319362.5	16.1	16.2	0.34	-0.41	-0.38	-0.37
13-07-2023 00:59	GP4409883	315125.2	0	319349.5	16.1	16.2	-0.59	-0.34	-0.32	-0.3

**List of Tables**

S.NO	Table No:	Details of the Table
1.	Table 1	Performance summary of the CoPA for the FY 2022-23
2	Table 2	Quarter wise performance of the CoPA for the FY 2022-23
3	Table 3	Category wise consumers and Energy Sales for the FY 2022-23
4	Table 4	Infrastructure details
5	Table 5	Voltage based consumers and metering infrastructure
6	Table 6	Feeder wise Energy Distribution in Willingdon Island
7	Table 7	Metering target
8	Table 8A	Name and details of the Energy Manager and authorised signatory DISCOM
9	Table 8B	Centralised Energy accounts and Audit Cell in CoPA (Team members)
10	Table 9	Infrastructure details
11	Table 10	Voltage wise consumers metering infrastructure and other assets
12	Table 11	Distribution Transformer details
13	Table 12	Performance summary of the Cochin Port Authority for the FY 2022-23
14	Table 13	Energy input particulars of CoPA for the FY 2022-23
15	Table 14	Energy Sales Particulars of CoPA for the FY 2022-23
16	Table 15	Category wise consumers
17	Table 16	Energy Input Particulars of CoPA for the FY 2022-23
18	Table 17	Energy sales Particulars for the FY 2022-23
19	Table 18	Validation details of the metered data
20	Table 19	Physical verification of meters at Substation
21	Table 20	Power purchase details of the Willingdon Island
22	Table 21	Power purchase details of the Vallarpadam & Puthuvypin area
23	Table 22	Month wise statements generated from Software
24	Table 23	Consolidated total for the FY 2022-23
25	Table 24	Validation of Energy sales Particulars
26	Table 25	Energy accounts for the previous years
27	Table 26	Energy accounts and performance for the FY 2022-23
28	Table 27	Quarter wise Energy Input details for the FY 2022-23
29	Table 28	Quarter wise Energy Sales and Loss details for the FY 2022-23
30	Table 29	Month wise T&D Loss performance of the Willingdon Island and Vallarpadam area
31	Table 30	Feeder wise distribution under the Willingdon Island
32	Table 31 A	Category wise consumption and revenue realisation for the FY 2022-23
33	Table 31 B	Quarter wise and category wise revenue realisation for the FY 2022-23
34	Table 32 A	Status and progress in compliance with the Prerequisites for the Energy accounting
35	Table 32 B	Status and progress in compliance with the reporting requirements of the regulation
36	Table 33	Action plan for monitoring and reporting
37	Table 34	Action plan for automation

ANNUAL ENERGY AUDIT REPORT OF COCHIN PORT AUTHORITY FOR THE YEAR 2022-23

38	Table 35	Audit team
39	Table 36	Check list prepared by thr Empanelled accredited auditing Firm
40	Table 37	Infrastructure details
41	Table 38	Voltage based consumers and metering Infrastructure
42	Table 39	List of Transformers
43	Table 40	Feeder wise load distribution under the Willingdon Island distribution system
46	Table 41	Energy performance of the previous years
47	Table 42	Analysis of performance of the two distribution areas under the CoPA
48	Table 43	Power purchase details of the Willingdon Island
49	Table 44	Power purchase details of the Vallarpadam
50	Table 45	Category wise consumers and average billing rate
51	Table 46	Category of service details
52	Table 47	List of documents verified with each parameter
53	Table 48	Peak load measurement details of the Transformers

## List of Figures

S, NO	Fig Number	Figure details
1	Fig 1	Quarter wise performance of the CoPA for the FY 2022-23
2	Fig 2	Quarter wise T& D Loss performance for the FY 2022-23
3	Fig 3	Category wise consumption for the FY 2022-23
4	Fig 4	Category wise consumption for the FY 2022-23
5	Fig 5	Power input details in the two areas
6	Fig 6	Annual T&D Loss performance against the PAT Target
7	Fig 7	Quarter wise T&D loss performance for the FY 2022-23
8	Fig 8	Quarter wise and Category wise unit consumption for the FY 2022-23
9	Fig 9	Month wise T&D loss performance for the two Areas
10	Fig 10	Month wise T&D loss performance for the two Areas
11	Fig 11	SLD of the Willingdon Island Distribution system
12	Fig 12	SLD of the Vallarpadam area
13	Fig 13	Photo of the Feeder meter in the Feeder Q9-2
14	Fig 14	Photo of the Feeder meter in the Feeder UTL
15	Fig 15	Photo of the Feeder meter in the Feeder Q9-1
16	Fig 16	Photo of the Feeder meter in the Feeder NTRAO A2