



# COCHIN PORT TRUST DISASTER MANAGEMENT ACTION PLAN

## INDEX OF CONTENTS

	CONTENTS	PAGES NO	REV REF/DATE
<b>PART-1</b>	<b>Framework</b>		
<b>SECTION</b>			
<b>1</b>	<b>Introduction</b>	<b>6</b>	
1.1	Over view of CoPT	<b>7</b>	
1.2	Purpose of plan	<b>8</b>	
1.3	Scope of the plan	<b>9</b>	
1.4	Authorities, Codes, Policies	<b>10</b>	
1.5	Institutional arrangements for Disaster Management	<b>11</b>	
1.6	Plan Management	<b>12</b>	
<b>2</b>	<b>HRVA</b>		
2.1	History of Disasters		
2.2	Hazard,Risk and Vulnerabilty mapping	<b>13</b>	
2.3	Emerging concerns		
<b>3</b>	<b>Prevention &amp; Mitigation</b>	<b>16</b>	
3.1	Monitoring of Hazards and threats		
3.2	Preventive and Mitigation Measures		
3.3	Public warning		
<b>4</b>	<b>Main Streaming DM plan in developmental projects</b>	<b>17</b>	
<b>5</b>	<b>Preparedness</b>	<b>18</b>	
<b>6</b>	<b>Response</b>	<b>21</b>	
<b>7</b>	<b>Recovery</b>	<b>33</b>	

<b>PART-II</b>	<b>Hazard Specific Incident Action (IAP)</b>		
01	<b>CARGO RELATED ACCIDENTS</b>		
	AMMONIA GAS LEAK	<b>35-37</b>	
	CHEMICAL/ACID SPILLAGE	<b>38</b>	
	FIRE & EXPLOSION	<b>39-43</b>	
	OIL SPILL	<b>44</b>	
02	<b>VESSEL ACCIDENTS</b>		
	COLLISION	<b>45</b>	
	FIRE-EXPLOSION	<b>46</b>	
	BUNKERS OVER FLOW/ SPILL	<b>47</b>	
	GROUNDING-SINKING	<b>48</b>	
03	<b>NATURAL CALAMITIES</b>		
	CYCLONES	<b>49-55</b>	
	FLOODS	<b>56</b>	
	EARTHQUAKE/I	<b>57</b>	
	TSUNAMI	<b>58</b>	
04	<b>SECURITY THREATS</b>		
	BOMB THREATS	<b>59</b>	
	WAR ALERT	<b>60</b>	
05	LOCAL STRIKE CONTINGENCY PLAN	<b>61-62</b>	
	<b>APPENDICES</b>		
A	TEL NOS OF GOVT CONTACTS-OFF-SITE	<b>63</b>	
B	SAFETY DATASHEET AMMONIA	<b>64-65</b>	
C	SAFETY DATASHEET PHOSPHORIC ACID	<b>66-67</b>	
D	STORM SIGNALS	<b>68-69</b>	
E	TERMS & DEFINITIONS	<b>70-71</b>	



### DISTRIBUTION LIST

COPY HOLDER	COPY NO.	COPY HOLDER	COPY NO.
Chairman	1		
Dy. Chairman	2		
<b>GEN ADMINISTRATION DEPT</b>			
Secretary	3		
<b>MARINE DEPT</b>			
Deputy Conservator	4		
Harbour Master	5		
<b>TRAFFIC DEPT</b>			
Traffic Manager	6		
<b>MECHANICAL DEPT.</b>			
Chief Mechanical Engineer	7		
<b>CIVIL ENGINEERING DEPT</b>			
Chief Engineer	8		
<b>FINANCE DEPARTMENT</b>			
FA&CAO	9		
<b>MEDICAL DEPT</b>			
CMO	10		
<b>CISF</b>			
Commdt CISF	11		
<b>FIRE SERVICE</b>			
CFO	12		

**PART-I**  
**FRAME WORK**

## **SECTION 1 - INTRODUCTION**

**Introduction-** Maritime transport, by its nature gives rise to many hazardous situations, including shipping accidents, such as collisions, grounding and sinking, accidents arising from the handling and storage of dangerous goods including bulk chemicals, gas and petroleum.

It has long been recognized that port areas represent a complex interface between land and sea, between human activities and the natural environment and between different transport nodes. Due to a port's geographical location, it is also exposed to natural disasters like cyclones, floods, earthquakes, Tsunamis etc. The compliance requirements of the ISPC Code and the Dock Workers Regulations are an ongoing process to promote safety and security in the port.

Port areas usually have a large number and range of potentially hazardous activities going on in close proximity to each other. Port areas are often built up areas that are close to housing and other community facilities and some times adjacent to important fisheries, wild life habitats and recreation areas. An incident in one part of the port may well affect the surrounding community and environment, as well as other port facilities. Incident Prevention by Preparedness, response and mitigation backed up with sufficient resources are the key elements for attaining the objectives of these Disaster Management Action plans.

## SECTION 1.1 - OVERVIEW OF THE COCHIN PORT TRUST

### Organisation chart

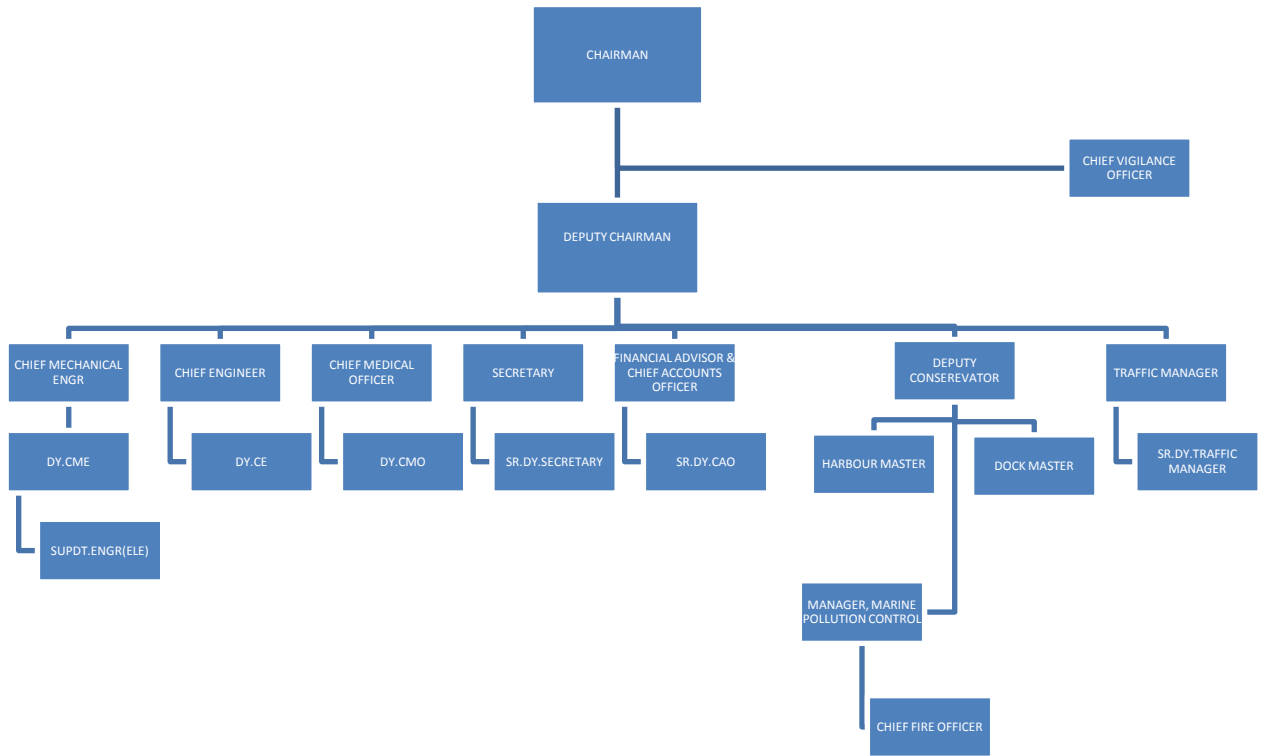



## SECTION 1.2 - PURPOSE OF THE PLAN

The enclosed document entitled “**COCHIN PORT TRUST DISASTER MANAGEMENT PLAN**” is prepared with the objective of defining the functions and responsibilities of all concerned Cochin Port Trust managerial, operational and departmental personnel with respect to preparedness, detection and effective implementation of the Disaster Management plan.

The plan objectives are as follows:

1. Rapid response, control and containment of a hazardous situation
2. Mitigation of the risk and impact of the event or accident to life, property and the environment.
3. Effective temporary rehabilitation of the affected persons during the period of crisis.

The elements of this plan are

- Reliable and early detection of an emergency such as Fire, explosion, toxic gas leakage, oil / chemical leakage / spillage, natural calamities like cyclones, floods, tsunami, earthquake, vessel related accidents such as collisions, grounding, sinking, fire and security related incidents.
- The alertness and preparedness status.
- The availability of port owned appropriate resources for handling emergencies and sourcing of additional resources and logistical support from govt. agencies
- Appropriate emergency response actions at port, and coordination at district and national level when required
- Effective communication channels and facilities

## **SECTION 1.3 - SCOPE OF THE PLAN**

*The on-site plan deals with emergencies which originate and are contained within the port area whereas the off-site plan addresses the impact of disasters spreading outside from the port boundary and those from outside impacting into the port area.*

*Offsite plans also address the following:*

### **Co-ordinating with other response agencies**

- *Interact with other emergency response agencies*
- *Co ordinate emergency plans and procedures*
- *Mutual aid assistance*
- *Open lines of communication- information sharing*
- *Joint education and training- common problem solving*

### **With Local Government**

- *Provide a safe community*
- *Ensure the well being of all residents and transients within the community*
- *Establish public safety programmes*
- *Coordinate port/ community emergency response forces during drills and emergencies*
- *Consider training, drills and exercises with other response agencies within the community, are and state.*

## SECTION 1.4 - AUTHORITIES, CODES, POLICIES

- **Authorities**

Cochin Port Trust

District / State Administration

Ministry of Shipping, Govt. of India

- **Codes**

MARPOL 73/78 regulations (as amended) of IMO.

International Tanker safety Guide for oil tankers and terminals(ISGOTT)

Environment Protection Acts of Govt of India.

Cochin Port Trust Rules & Regulations

Merchant Shipping Act 1958

Major Port Trust Act 1963

Indian Ports Act 1908

**SECTION 1.5- INSTITUTIONAL ARRANGEMENT OF DISASTER MANAGEMENT IN ORGANIZATION**

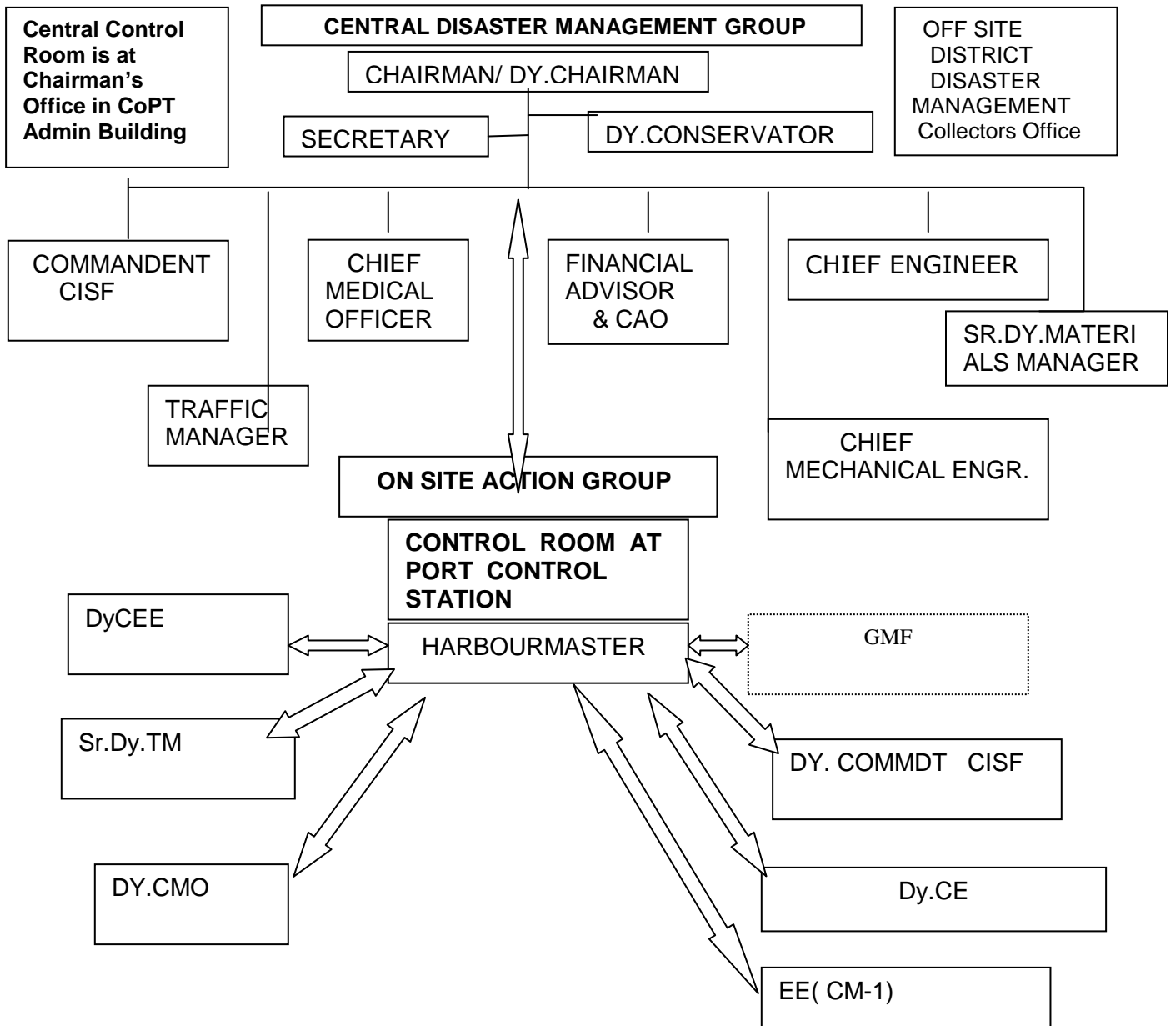

## **SECTION 1.6 - PLAN MANAGEMENT**

**Plan Developed by** : Manager, Marine Pollution Control

**Review by** : Deputy Conservator & Dy. Chairman

**Approval by** : Chairman, Cochin Port Trust



pipeline										
Trucks/Mobile eqmt			x		x	x	x	x	x	x
Train tracks-Roads						x			x	x
Cranes & Ship Loaders						x	x	x	x	x
Bulk cargo conveyor system						X	X	X	X	X
<b>SERVICES</b>	-----	----	-----	-----	-----	-----	-----	-----	-----	----
Control gates			x			xx		x	x	x
Emergency Generators			x			x	x	x	x	x
Electric Substations			x			x	x	x	x	x
Train siding Locos, Wagons,			x			x	x	x	x	x
Signal station-SATCOM commn			x			x	x	x	x	x
Fire station 1 & 2			x			x	x	x	x	x
Port tugs, crafts, dredger	x	x	x		x	x	x	x	x	x
<b>ADMINISTRATION</b>	-----	----	-----	-----	-----	-----	-----	-----	-----	----
Administration Building & Parking			x	x		x	x	x	x	x
Customs Area & Weigh Bridge			x	x		x	x	x	x	x
Port officers & CISF Quarters			x	X		x			x	x

### EVENT SCENARIOS - COCHIN PORT TRUST

**Probability-Low=once ev 10-50yrs:: moderate=once ev 2-10yrs; High=once annually**  
**Impact/Preparedness/Risk Threat 0=Very Low, 1=Low, 2=moderate, 3=High**

EVENT/ SCENARIO → SPECTRUM ↓	Early Warning	Probability of Occurance	Duration Impact	Impact on property	Impact on people	Time to Restore Facilities	RISK THREAT
Cyclone	96h-12h	Low	N/A	1	1	N/A	Low
Floods	96h-12h	Low	N/A	1	1	N/A	Low
Earthquake/Tsunami	5-8h	low	N/A	1	1	N/A	Low
<b>V/L Accident</b>							
Collision	< 1min	Low	<1hr	0	0	4 h	Low
Grounding	< 1min	Low	2-4hr	0	0	4 h	Low
Fire/Explosion	< 1min	Low	0.5-12h	1-2	1-2	12-96h	Mod
<b>Transport Accident</b>							
Rail	< 1min	Mod	< 1min	0	1	6-48h	Low
Road Accident	< 1min	Mod	< 1min	0	1	<1h	Low
<b>Pollution-</b>							
Gas Release-Ammonia	< 1min	Low	1-24h	0.1	2	2-30d	Low
Phos /sulph acid spill	< 1min	Low	1-12h	0.1	1	2-4d	Low
Oil Spill	< 30min	Low	1-12h	1	1	1-2d	Low
<b>Fire-Admin Building</b>	< 10min	Low	1-72 h	1	1	12-96h	Low
Parking/Gates	< 1min	Low	1-12h	0	1	12-96h	Low

<b>Function Failure</b>							
Elec sub station	< 1min	<b>Low</b>	<b>1-24h</b>	<b>0</b>	<b>0</b>	12-48h	<b>Low</b>
Emergency Generator	< 1min	<b>Low</b>	<b>1-24h</b>	<b>0</b>	<b>0</b>	12-48h	<b>Low</b>
Pipelines failure	< 1min	<b>Low</b>	<b>1-24h</b>	<b>0</b>	<b>0</b>	12-48h	<b>Low</b>
Evacuation routes	< 1min	<b>Low</b>	<b>1-24h</b>	<b>0</b>	<b>0.2</b>	12-48h	<b>Low</b>
Fire Alarm failure	< 1min	<b>Low</b>	<b>1-24h</b>	<b>0</b>	<b>0</b>	12-48h	<b>Low</b>
Fire station failure	< 1h	<b>Low</b>	<b>1-24h</b>	<b>0</b>	<b>0</b>	12-48h	<b>Low</b>
Water system	< 1h	<b>Low</b>	<b>1-24h</b>	<b>0</b>	<b>0</b>	12-48h	<b>Low</b>
Communications	< 1h	<b>Low</b>	<b>1-24h</b>	<b>0</b>	<b>0</b>	12-48h	<b>Low</b>
Medical facilities	< 1d	<b>Low</b>	<b>1-24h</b>	<b>0</b>	<b>0</b>	12-48h	<b>Low</b>
Sewerage failure	< 1h	<b>Low</b>	<b>1-24h</b>	<b>0</b>	<b>0</b>	12-48h	<b>Low</b>
<b>Human related</b>							
Labour Action/Strike	24h	<b>mod</b>	<b>&lt;24h</b>	<b>0</b>	<b>0</b>	12-48h	<b>Mod</b>
Civil disturbance	< 1d	<b>mod</b>	<b>&lt;24h</b>	<b>0</b>	<b>0</b>	12-48h	<b>Mod</b>
<b>Terrorism &amp; War</b>							
State of War	<7 d	<b>Low</b>	<b>&gt;7d</b>	<b>0</b>	<b>3</b>	>48h	<b>Low</b>
Bomb Threat	< 3h	<b>Low</b>	<b>1-96h</b>	<b>0</b>	<b>1</b>	>48h	<b>Low</b>
Hostage Threat	< 3h	<b>Low</b>	<b>1-96h</b>	<b>0</b>	<b>0.5</b>	>48h	<b>Low</b>
Mass Casualty	< 3	<b>Low</b>	<b>1-96h</b>	<b>0</b>	<b>1</b>	>48h	<b>Low</b>



## **SECTION – 3: PREVENTION AND MITIGATION**

### ➤ **3.1 Monitoring of Hazards and Threat**

- Perceive the threat
- Assess the hazard
- Select control strategy
- Control hazard
- Monitor hazard

### ➤ **3.2 Preventive and Mitigation Measures**

- Analyze the hazard
- Determine prevention / protection action
- Determine public warning
- Determine prevention/ protective action implementation plan

### ➤ **3.3 Public warning**

#### **3.3.1 Determine message content**

#### **3.3.2 Select appropriate public warning systems**

**ALERT ALARM**

**: - SOUNDING OF SIREN FOR 10 SECONDS WITH  
A GAP OF 5 SECONDS FOR ONE MINUTE**

**TERMINATION OF EMERGENCY:- CONTINUOUS SOUNDING OF THE SIREN FOR  
ONE MINUTE**

#### **3.3.3 Disseminate public warning**

#### **SECTION-4 : Mainstreaming DM plan in developmental projects**

New projects locations are to be chosen taking into following considerations

- LPG/LNG/Tanker berths to be located away from populated areas.
- Sufficient protection in the form of seawalls/ breakwater for safe berthing of tankers and cargo handling.
- Sea room available for emergency unmooring of tankers.
- Effect of prevailing winds and coastal current on spillage of cargo incase of loading arm/ hose leak/ overflow etc.
- Water intakes free of silt for fire fighting water.

## **SECTION-5: Preparedness**

### **5.1 Preventive/ protective action implementation**

### **5.2 Access control and isolation of danger area**

### **5.3 Evacuation support**

Evacuation Operation will be coordinated by the Commdt.CISF

#### **EVACUATION ACTION-COORDINATION AND SPECIFIC FOLLOW UP**

<b>DEPT &amp; ACTION BY</b>	<b>SPECIFIC ACTION</b>
Administration -Secretary	1- <b>Overall Supervision</b> of Evacuation & Reports to Chairman
Traffic & CISF	2- <b>Evacuation of work force</b> at harbour area.
Administration - PRO	3- <b>Announcement</b> of Evacuation through PA on mobile units
Administration -Dy Secy & Estate Officer	4- <b>Arrange Relief Centres</b> ready to accommodate evacuated persons
Administration- Dy.Secy(G)	5- <b>Procure Transport vehicles</b> to transport persons at relief centres
Civil Eng - Addl CE	6- <b>Provide</b> adequate <b>Drinking water</b> at temporary evacuation shelters
Medical - Dy CMO	7- <b>Provide</b> Medicine and <b>First Aid</b> at Assembly points & relief centres
CME Dept. EE	8- <b>Provide adequate lighting</b> at temporary evacuation shelters
Administration- PRO	9- <b>Provide food</b> at temporary evacuation shelters
Comdt CISF	10- <b>Confirmation</b> that evacuation operations are complete
Administration-Secretary	11- <b>Status Report</b> to Chairman/Dy Chairman <b>every hour</b>

#### **EVACUATION ROUTES**

	<b>INCIDENT</b>	<b>EVACUATION ROUTES ( APPENDIX PORT LAYOUT)</b>
1	<b>NATURAL CALAMITIES</b>	Assemble near the Fire station (Coordinated by CFO & CISF )
2	<b>TOXIC GAS RELEASE</b>	The route decision will be determined depending upon the wind direction at the time of the incident .It will be in <b>the up wind direction of the outflow source direction.</b> <b>(Coordinated by CFO and CISF)</b>
3	<b>FIRE AT OIL BERTH</b>	Assemble at the muster station to proceed out as directed <b>(Coordinated by CFO &amp; CISF)</b>
4	<b>FIRE AT GEN. CARGO BERTH</b>	Assemble at the Ernakulam Wharf Gate & Mattancherry Gate <b>(Coordinated by CFO &amp; CISF)</b>

All vehicles whether it is of Port Trust or hired should be parked in the location as decided by Secretary, CoPT from where it can be taken for immediate use as soon as the people move into action.

### **5.4 Decontamination support**

### **5.5 Medical treatment**

### **5.6 Special population support**

### **5.7 Search and rescue**

Search and Rescue Operation will be coordinated by the Commdt.CISF

## 5.8 Resources management

## 5.9 Training and capacity building

## 5.10 Communication/ Early warning

### Communication Systems

Vulnerability is partly a function of the degree of protection available to potential victims as a result of a disaster. Improved warning reduces vulnerability. 'Warning' incorporates the communication of risk in times of impending emergencies, with the purpose of obtaining public protective actions through the implementation of the Disaster Management Plan.

### Communication Network Elements within the Port on Site

Internal Fire Service	Special fire alarm and normal communication system- VHF-TELEPHONE-EPABX-WALKIE TALKIE- MOBILE
Forward control	UHF/VHF Transceivers-normal communication systems in reserve
Personal and internal Medical services	Normal communication services
Fire fighting craft and Rescue launches	UHF/VHF Radio telephones, Via port authorities as reserve
Ships at Berth	Normal UHF/VHF Radio telephone link used in cargo operations..Terminal representative at tanker berth to also have own radio
Civil authorities Including fire services, Police and medical services	Direct telephone link with failure alarm,UHF/VHF radio telephone or public telephone system. Cascade system to be used i.e. through dept heads to subordinates Enable keep lines clear
Harbour authorities, Pilots, tugs and other harbour craft	UHF/VHF Radio telephone or public telephone
District Collector or State Secretary	UHF/VHF Radio telephone, public telephone-hot line for emergency level 2 & 3-
Jt Secretary-MOSSt New Delhi	Public telephone-hot line for emergency level 2 & 3

<b>MANAGEMENT</b>	<b>MOBILE VHF</b>
Secretary, C E, CME, Traffic Manager Dy Conservator- Comdt CISF - CFO Port Entry Gates- Harbour Master	Walkie talkie
Port Control	VHF / Walkie Talkie

### **IN CASE OF ANY EMERGENCY CONTACT PORT CONTROL**

**TEL 2666468  
VHF Ch 16/15/14**

### **IN CASE OF FIRE CONTACT**

**FIRE : 102  
TEL NO : 2666555**

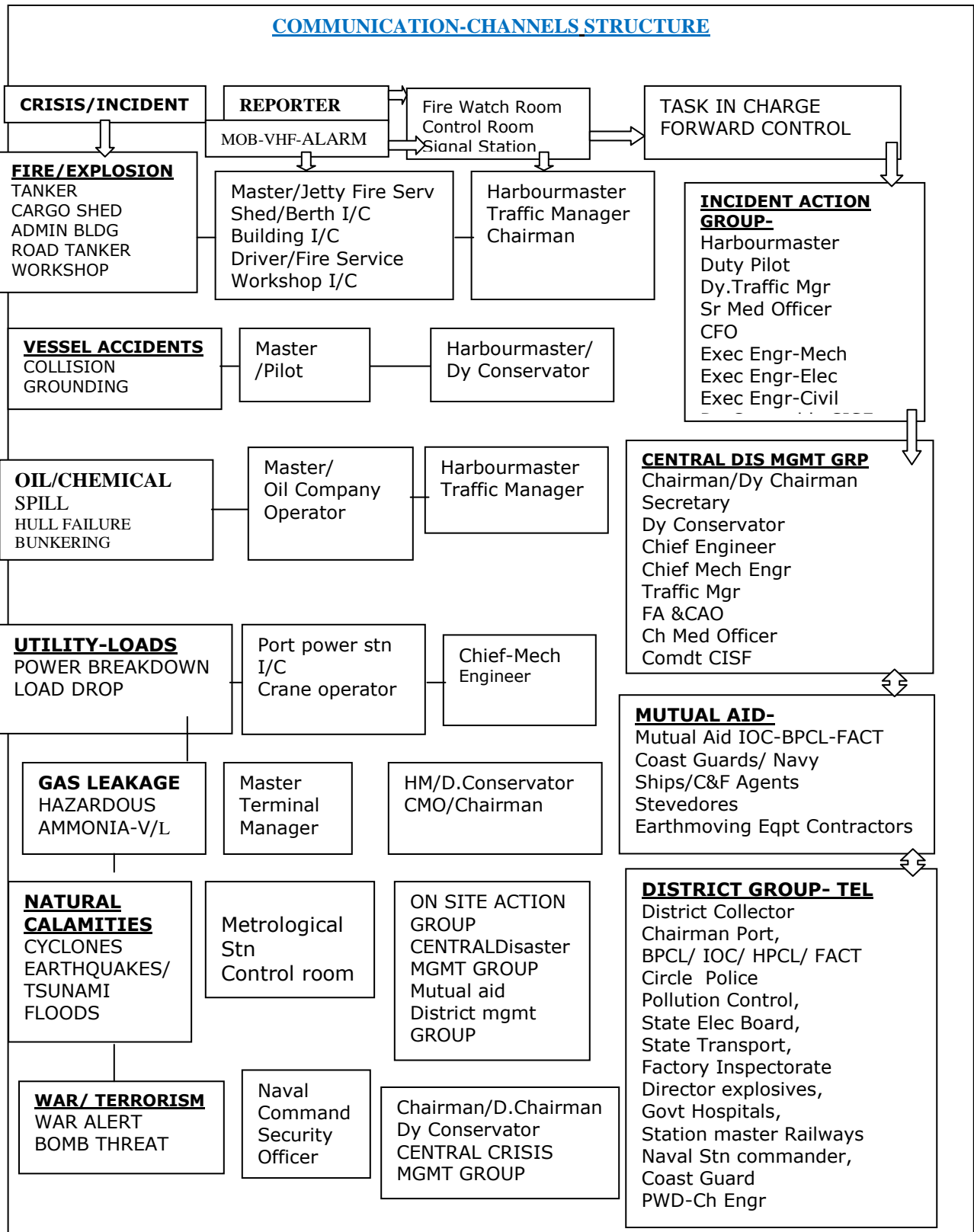

**5.11 Drills and exercises**

Periodic drills and exercise to be conducted to validate the preparedness.

**SECTION-6: Response**

**COCHIN PORT DISASTER MANAGEMENT CONCEPTUAL PLAN FRAMEWORK**

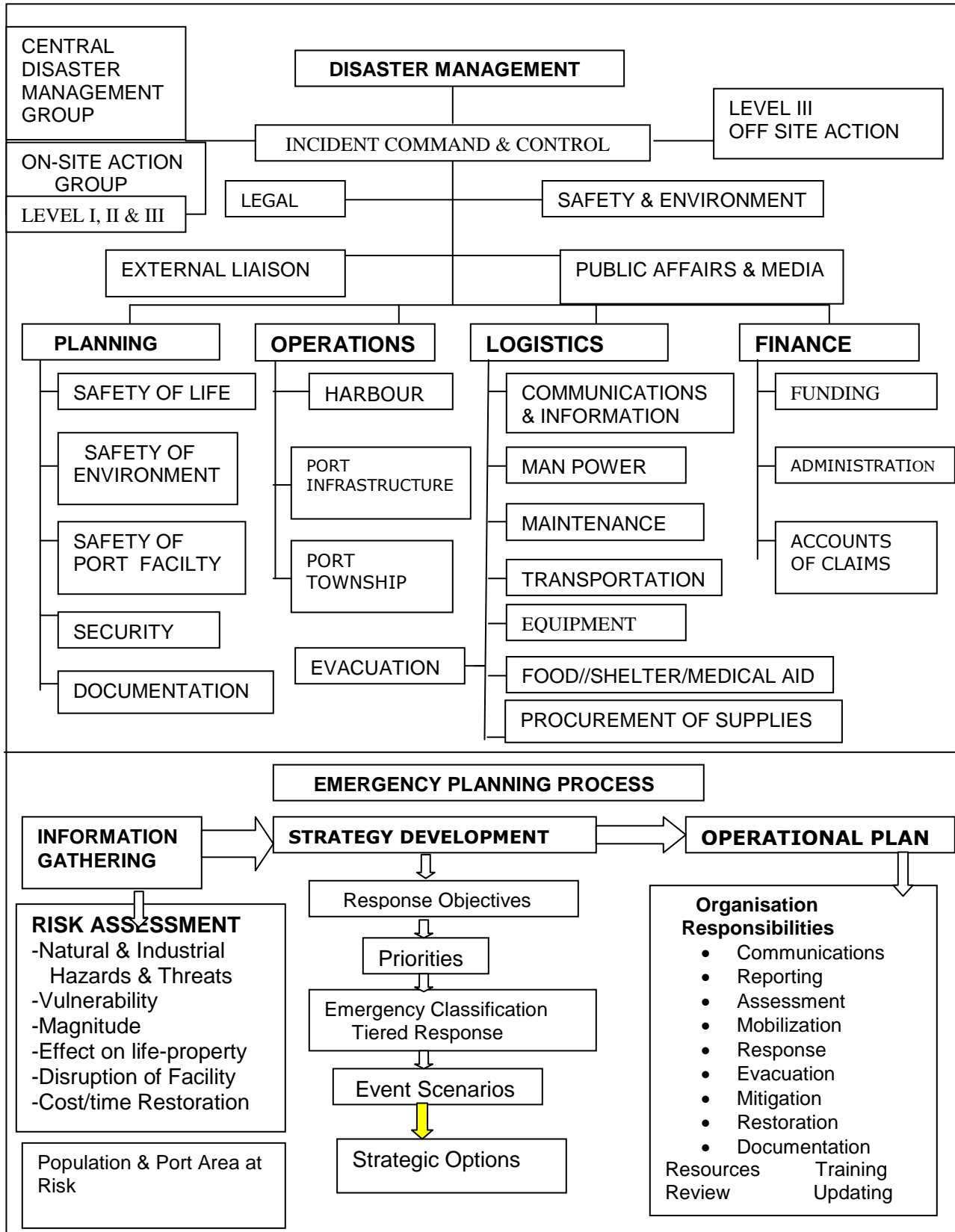

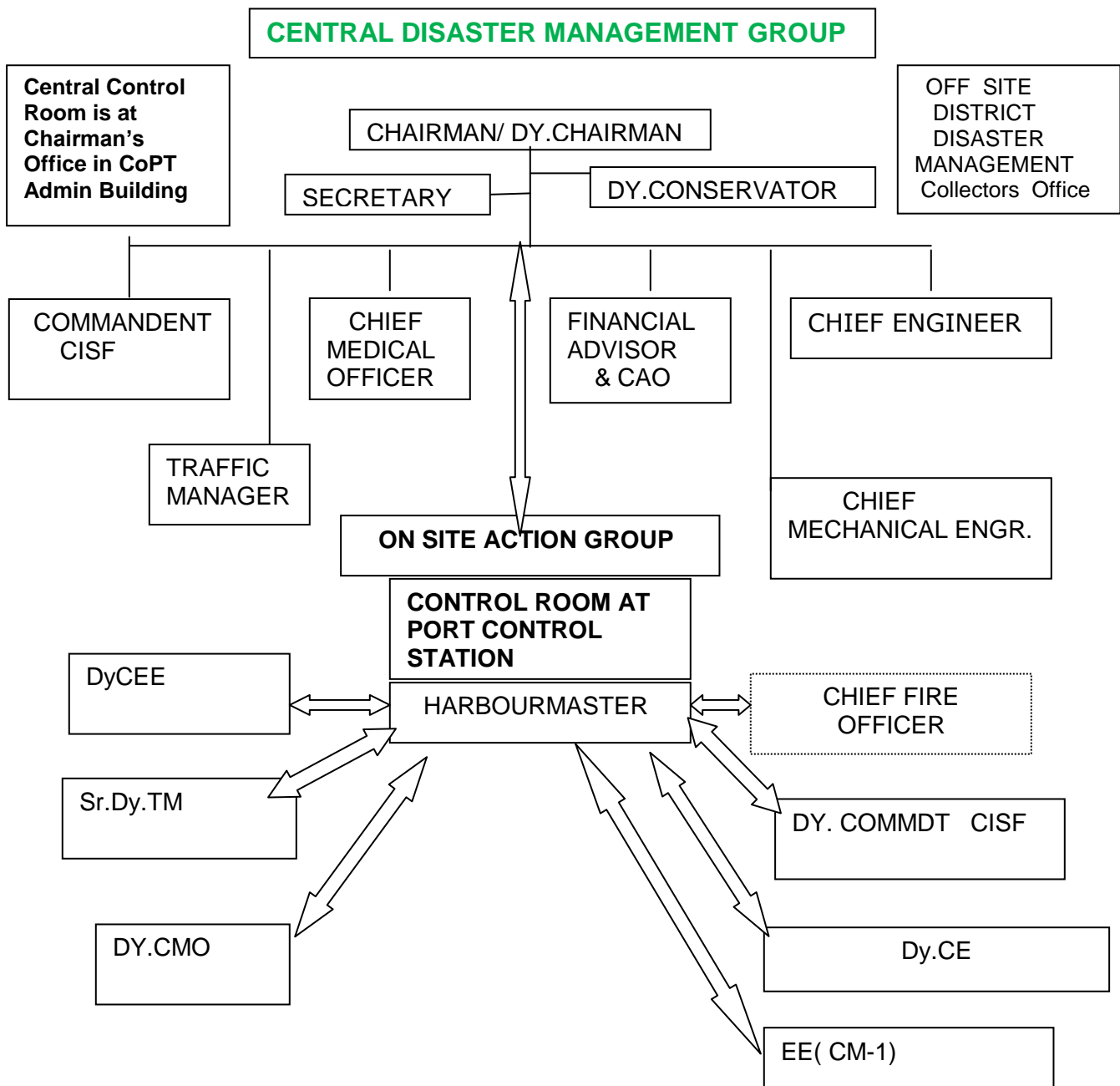

**INITIATION OF CENTRAL CONTROL ROOM - On Emergency level II or III**

Chairman CoPT to decide whether members of the Central Disaster Mgmt Team will operate from their respective dept control rooms and attend joint meetings at the Central Control Room at fixed timings or when total central control room attendance is required. Whenever the Central Disaster Management Team takes over responsibilities- the On Site Action Group now reports to the Central Control. Whenever the District Off Site Disaster Mgmt Group is initiated both Central Control and On Site Action Group will continue to function under the CoPT's declared Emergency level

## CENTRAL DISASTER MANAGEMENT GROUP- BASIC FUNCTIONS

<b>Team Leader:</b> Chairman / Dy Chairman
<b>Members:</b> Dy Chairman , Secretary, FA & CAO, Chief Engineer, CME , Traffic Manager, Materials Manager, Chief Medical Officer, Commandant-CISF , Commandant – Coast Guard.
<b>Basic Functions</b>
1-Monitor and analyze reports from the On Site Action team and identify the area/population at risk
2-Activate the Response Plan and arrange the Alert siren.
3-Support the Action Group with materials, equipment, information and human resources
4- Implement changes in the current mode of action if deemed necessary
5-Adjust the Disaster classification of the incident and actuate the Central Control Room
6- Coordinate with external organizations, State Govt. as deemed necessary
7- Make the necessary arrangements and funds for evacuation, transportation, food & supplies
8-Make media statements and reports to MOS.

## ON SITE ACTION GROUP - BASIC RESPONSIBILITIES

<b>Team Leader:-</b> Harbour Master / Senior Pilot
<b>Members:-</b> Control room-Sr.pilot, Chief Fire Officer, Dy Comdt.CISF, Exec.Engineer (Electrical) Addl. TM, Dy Chief Med. Officer.
<b>Basic Functions</b>
1- Assess & classify Incident:-nature-location- severity-casualties-resource requirement –time to control
2- Activate elements of the disaster management plan, arrange alert signal in liaison with DC
3-Conduct search, rescue and evacuation operations. Provide medical Aid
4- Manage incident operations and terminate plan, Arrange for re-Entry and restoration

## EMERGENCY CLASSIFICATION

**Level 1.** It is an Incident within the port and is of a minor nature with a low level of personnel injury, interruption to work,damage level and loss of capability.It can be handled by the Port Trust Staff involving Marine and other depts. The Emergency Management group leader is the Dept Head. E.g. Building/Shed Fire, Elec Supply disruption, labour accident, vessel accidents

**Level 2;-** It is an Incident within the port area and is of a limited and moderate level of personnel injury,possible death(s),interruption of work,damage to port ..Besides Port resources, outside assistance may be required. The Disaster Management group leader is the Chairman, CoPT. E.g. Gas Leaks, Chemical/Oil Spills, Terminal Fires/ Explosions

**Level 3:-** It is a disaster of a severe and critical nature and could have a high level of personnel injury (and deaths), interruption to work, damage to port and loss of capability. It affects the port and possibly adjacent areas. Besides Port resources, assistance from outside agencies is required. If incident affects CoPT, group leader is chairman, CoPT and if it affects outside CoPT then information will be given to District Collector depending on the intensity. E.g. Gas Leaks, Chemical/Oil Spills, Fires/ Explosions & Cyclones

INCIDENT/REQUIREMENT SCENARIOS	LEVEL I – ACTION BY	LEVEL II & III –ACTION BY
Vessel –Grounding-Shifting-Evacuation	HM	HM + Salvage efforts + Navy + Coast Guard
Casualties	CMO	Port + District + State
Fire & Explosion on Vessel or Terminal	CFO	CFO + District (Fire wing) + CDMG
Fire & Explosion at Shed	CFO , TM	CFO + District (Fire wing) + CDMG
Oil or Chemical Spill	MMPC/ CFO	CFO +Central disaster Magnt. Group+ out side agencies
Toxic Gas Leakage	CFO	Central disaster Magnt. Group +District/state assistance + outside agencies
Cyclone, tsunami, flood etc	Dy.Conservtor	National disaster Management group + CDMG + District + state



<b>CENTRAL DISASTER MANAGEMENT GROUP - RESPONSIBILITIES</b>			
<b>Position</b>	<b>Port Position</b>	<b>Alternative</b>	<b>TEL</b>
<b>Chief Emergency Controller</b>	<b>Chairman</b>	<b>Dy Chairman</b>	<b>CONTACT</b>
Monitors Disaster Management action Plan and a state of emergency preparedness is maintained at all times. Authorises release of required funds. Leads Central Disaster Management group to direct operations from the emergency control center.			<b>Std(0484)</b> 2668200, 2668566 2582002
For industrial disasters, confirms level of crisis, monitors the shutting down, evacuation and other operations as necessary. Directs activation of the Central Control room at emergency level 2 and 3			<b>Res. Tel:</b> 2668100 2582900
Activates the off site emergency plan if the disaster is spreading to/from outside Port boundary in liaison with Dy chairman, DC, TM and CFO			
Approves information to the media			
Liaises with the Secretary, Jt. Secy (Ports) of the MOS (Ministry of shipping)			
Confirms the termination of the emergency.			
<b>Leads</b> the Central Disaster Management Group, monitors the early restoration of facilities and port activities,			
<b>2-</b> Provides timely required status reports to the Secretary MOS			

<b>CENTRAL DISASTER MANAGEMENT GROUP RESPONSIBILITIES</b>			<b>TEL</b>
<b>Group Position</b>	<b>Port Position</b>	<b>Alternative</b>	<b>CONTACT</b>
<b>Welfare &amp; Media Coordinator</b>	<b>Secretary</b>	<b>Sr.Dy.Secretary</b>	<b>Off Tel</b>
Co-ordinates cyclone response-acts as media spokesman			2666412
Prepares a duty roster for manning of the cyclone coordination centre by officers of the Administration, Finance & Accounts and Materials Management.			2582100
Mobilises vehicles. Arranges food and water to the personel on roster duty			2666424 2582126
Liaises with MOS and communicates inputs from the Chairman.			
Liaises with media as spokesman under guidelines of the Chairman			
Co-ordinates cyclone response plan and keeps constant touch with the local and District Administration to render assistance			
Secretary / Deputy Secy.(G) to arrange for evacuation of the township			
Maintains list of missing persons			
Monitors vehicles from shortlisted transport pool			
Provides a report to MOS			

### CENTRAL DISASTER MANAGEMENT GROUP RESPONSIBILITIES

Group Position	Port Position	Alternative	TEL
<i>Chief Incident Controller</i>	<i>Dy. Conservator</i>	<i>HarbourMaster</i>	<b>CONTACT</b>
Ensures that the applicable implementation procedures are reviewed and revised annually. Assists Central Disaster Management Group to Direct operations from the emergency control center			9847049023 2666417 (o) 2582500 (o)
Monitors and forecasts cyclone tracks threatening Port. Ensures stoppage of shipment operation & evacuation of vessel during disaster.			2582950 (r)
Directs the site incident controller(HM) from control room			
Directs the shutting down, evacuation and other operations at the port			
Monitors on site personal protection, safety			
Monitors the search & rescue operation.			
Coordinates,organizes and obtains additional resources for operation			
Liaises with the senior operating staff of the Fire,Police,Coast Guards,Military and para military, Navy etc.			
Advises Central Disaster Group for the termination of the emergency situation			
Assist in assessing damages together with the CE,CME&TM			
Assists in the supervision & reconstruction of affected areas post disaster			
Preserves evidence and assists Secretary in the submission of logs for the claim process.			

### CENTRAL DISASTER MANAGEMENT GROUP RESPONSIBILITIES

Group Position	Port Position	Alternative	TEL
<i>Traffic Department</i>	<i>Traffic Manager</i>	<i>Dy. Traffic Manager</i>	<b>CONTACT</b>
Ensures evacuation of all dock workers and private labour, visitors, shippers, consignees from the port area.			<b>Off Tel</b> 2666418
Prepares vessels to vacate from berth to open sea			2582200
Arranges to protect cargo in port custody from damage by shifting			<b>Mobile</b>
Arranges to segregate dangerous cargo in sheds during fire			9447055054
Submits consolidated list of dangerous goods in port including tankers in port and tank farms in port area			2582920 (R)
Ensures his dept implements the disaster response plan and assists in segregating and shifting cargo and coordinating with the Fire Fighting Authorities			
Informs all cargo interests,Port Agents,stevedores regarding restoration of the port operation.			

### CENTRAL DISASTER MANAGEMENT GROUP RESPONSIBILITIES

Group Position	Port Position	Alternative	TEL.
<b>Cash &amp; Accts.</b>	<b>FA &amp; CAO</b>	<b>Dy FA &amp; CAO</b>	<b>CONTACT</b>
Maintains cash / funds for disbursement to all the depts			2666582 (O) 2582600 (O)
Disburses cash / funds to different departments			<b>Mob</b>
Provides Disbursement Statement to Secy. for processing claims			9526062088

<b>CENTRAL DISASTER MANAGEMENT GROUP RESPONSIBILITIES</b>			
<b>Group Position</b>	<b>Port Position</b>	<b>Alternative</b>	<b>TEL</b>
<b>CME Department</b>	<b>CME</b>	<b>Dy. CME</b>	<b>CONTACT</b>
Mobilises field groups for On Site Action Monitors implementation of plans for providing continuity of emergency supplies and services such as electric power, emergency lighting, pump, bulk material handling equipment etc. Coordinates with Dy. Materials Manager to procure essential materials Arranges for the fabrication of any specialised equipments required for the emergency Monitors that his field group have secured , loader, conveyors, mobile equipment , bulk material handling equipment, locomotives, cargo handling equipments etc.			2666639 (O) 2582300 (O) 9847049022
Monitors the appropriate procedures to isolate damaged units without introducing new hazards and providing resources both in terms of personnel and equipment to accomplish this			
Activates the necessary utilities during the emergency, like activating back up emergency generators for general lighting purpose, pumps, welding services etc.			
Monitors the rendering of assistance for rescue of trapped personnel by cutting structures, wires etc			
Ensures the dept. group remain alert on duty for any electrical isolation of equipment during an emergency			
Assess damages and provide technical assistance to determine the operability of damaged units.			
Assist in the accident investigation			

<b>CENTRAL DISASTER MANAGEMENT GROUP RESPONSIBILITIES</b>			
<b>Group Position</b>	<b>Group Port Position</b>	<b>Alternative</b>	<b>TEL</b>
<b>Engineerig Department</b>	<b>Chief Engineer - civil</b>	<b>Dy.Chief Engr – Civil</b>	<b>CONTACT</b>
1. Mobilises on-site action group to ensure proper functioning of the creek/culverts/Roads/ drainage system/Water supply system. 2. Ensures proper manning of the pump houses during the disaster 3. Ensures proper functioning of the drinking water supply to the relief/ cyclone shelter.			Off tel 2666414 (o) 2582400 (o) 9847049021(o) 2582940 (r)
4. Assists in recovery and port restoration activities			

<b>CENTRAL DISASTER MANAGEMENT GROUP RESPONSIBILITIES</b>			<b>TEL</b>	
<b>Position</b>	<b>Group</b>	<b>Port Position</b>	<b>Alternative</b>	<b>CONTACT</b>
<i>Security Coordinator</i>	<i>Dy. Commandant - CISF</i>		<i>Asst. Commandant CISF</i>	<b>Off tel</b> 2666579
Directs the gate security and facilitates evacuation, transport, first aid, rescue				2582150
Keep extra watch over stores, sub stations, berths, transit sheds, warehouses, administrative building, loco sheds.				<b>Res tel</b> 2667723
Controls the entry of unauthorized persons and vehicles-disperses crowd-cordons off restricted areas-prevents looting				<b>Mob.</b> 9847049055
Permits the entry of authorized personnel and outside agencies for rescues operations without delay.				
Allows the entry of emergency vehicles such as ambulances without hindrances				
Ensures that the people are as per the head count available with the assembly point section of that area to arrange for orderly evacuation				
Monitors that Dy Commndt CISF completes a reconnaissance of the evacuated area, to enable declaration of the same as evacuated and report to the Chief Incident controller				
Participates in recovery and re-entry activity				

<b>CENTRAL DISASTER MANAGEMENT GROUP RESPONSIBILITIES</b>			<b>TEL</b>	
<b>Position</b>	<b>Port Position</b>	<b>Alternative</b>	<b>CONTACT</b>	
<i>Medical Aid Coordinator</i>	<i>Chief Medical Officer</i>		<i>Dy CMO</i>	<b>Off tel</b>
Set up casualty collection centre and arrange first aid posts				2666402 (O)
Arrange for adequate medicine, antidotes, oxygen, stretchers etc				2582970 (R)
Advises Chief Incident Controller on industrial hygiene and make sure that the personnel on duty are not exposed to unacceptable levels of toxic chemicals				<b>Mobile</b> 9847049026
Makes arrangements of Ambulance for transporting and treating the injured				
Maintains a list of blood groups of each employee with special reference to rare blood groups. Arranges additional medicine and equipment as required				
Liaises with selected NGO's under instructions of the chairman				
Arranges Equipped Ambulance to be kept fully ready.				
Ensures that the casualty section of Port hospital has specialists				
Arranges for extra beds and in emergency contact with the state Govt. Hospital for extra medical supplies.				

<b>CENTRAL DISASTER MANAGEMENT GROUP RESPONSIBILITIES</b>			<b>TEL</b>	
<b>Position</b>	<b>Port Position</b>	<b>Alternative</b>	<b>CONTACT</b>	
<i>Logistics Coordinator</i>	<i>Sr. Dy. Materials Manger</i>		<i>Asst. Materials anager</i>	<b>Off tel</b>
Arranges purchase of stores and supplies				2667180
During cyclonic season sufficient stock of stores like GI corrugated sheets, J.Hooks, screw hinges, gunny bags, tarpaulins, ropes and wires for Port Crafts, diesel oil, kerosene oil, hurricane lantern, petromax lamps, torch lights with batteries and bulbs, electrical items etc. are kept.				2582467
All the materials which are likely to get damaged with rain are protected by a tarpaulin cover and raised above ground level.				
One Stores Supdt., one Store Keeper and the other minimum staff are required to issue materials including POL are kept during emergency.				
Informs FA&CAO the approximate funds required.				
He will replenish stock if possible				

## DISASTER MANAGEMENT ON SITE ACTION GROUP- ORGANIZATION RESPONSIBILITIES

Group Position	Port Position	Alternative	TEL
<i>Site Incident controller</i>	<i>Harbour Master</i>	<i>Senior Pilot</i>	<b>CONTACT</b>
<b>Directs and co-ordinates all field operations at the scene of the accident</b>			<b>Off tel</b>
Monitors early warning for cyclones and rescue operations			2666410
Assesses the level of incident -nature-location- severity-casualties and resource requirement			2582501
Classifies the incident - Advises Pilot at Port Control to convey to Main incident controller (HM) about Crisis Severity status and Emergency level , resource requirements etc.			Mobile 9847049056
<b>Activates elements of the terminal emergency plan / site response actions</b>			
<b>Coordinates</b> –in combating operation of the fire fighting and toxic gas leakage with the CFO,if Oil spillage with the Coast Guards, if Vessel accidents with the Dy Conservator, if Natural calamities like cyclone and floods, tsunami with the Secretary,CME,CE , for Cargo opn. shutdown with the Traffic Manager, for Search& rescue Sr. Comdt CISF, for First aid and hospitalization with CMO.			
Coordinates all functional heads in field operations group to take action			
Arranges tugs, mooring boats and pilot(s) for un-berthing vessel(s)			
Arranges for additional resources and periodic tactical and logistical briefings with Main Incident Controller (DyConservator) of CMG(Central Management Group).			
Liaises with Coast Guard, Navy and CISF Fire Service			
Co-ordinate with the search and rescue operations of CISF			
Manages incident operations to mitigate for re-Entry and restoration including channel hydrographic survey and navigation aids survey in liaison			
Arranges survey of damaged marine flotilla for necessary repairs			
Makes claims if the incident is due to the vessel from owners , P& I Club or agents			
<b>DISASTER MANAGEMENT ON SITE ACTION GROUP-ORGANIZATION RESPONSIBILITIES</b>			
Group Position	Port Position	Alternative	
<b>Communications Officer</b>	<b>Senior Pilot</b>	<b>Pilot</b>	
Maintains 24 h vigilance towards the channel/anchorage& port			2666410(o)
On receipt of instructions from the chief Incident controller, informs the fire brigade/CISF/HM			VHF Ch 14/15/16
Refrains from exchanging any information with unauthorized persons unless authorized to do so by the Chief Incident Controller			
Maintains contact with other vessels and on VHF			

### DISASTER MANAGEMENT ON SITE ACTION GROUP - RESPONSIBILITIES

Group Position	Port Position	Alternative	TEL
<b>Cargo Storage, Sheds &amp; Labour coordinator</b>	<b>Sr.Dy.TM</b>	<b>Dy.TM</b>	<b>CONTACT</b>
Co-ordinate with HM in de-berthing vessel to vacate the berth			2666070(o)
Arranges to segregate and protect cargo in sheds			2582201(o)
Submits consolidated list of dangerous goods in port including tankers in port during fire.			Mob 9847449034
Coordinates with shipowners/agents/C & F agents/stevedores and with labour Officer to arrange and ensure evacuation			2582921(r)
In case of Fire at Cargo BETHS/Transit Sheds - liaises with Dy Commdt CISF Fire to extinguish fire and in search and Rescue Operations			

### DISASTER MANAGEMENT ON SITE ACTION GROUP- RESPONSIBILITIES

Group Position	Port Position	Alternative	TEL
<b>Fire Search &amp; Rescue</b>	<b>CFO</b>	<b>Fire Officer</b>	<b>CONTACT</b>
Keeps all firefighting appliances and resources in readiness Maintains patrols and ensure unsafe practices are eliminated Liaises with Site Incident controller(HM) and is responsible for keeping the Fire Dept in a state of alertness on a 24 hour basis.			Off tel 2666555 Mob: 7736805496
Sounds action alarm at the Fire station. Keeps HM,DC, Chairman,Dy Chairman informed the level of crisis & leads team directly to incident site			
Initiates fire fighting procedures immediately and ensures fire fighting team reaches the incident location with the correct resources.			
Assists CISF in the evacuation of workers to the assembly points in liaison with the Dy. Commandant CISF			
Informs Site Incident Controller (HM) if external fire tender/fire fighting equipment /materials is required			
Arranges safety equipment e.g. fire suits, protective gloves and goggles, breathing apparatus as required			

### DISASTER MANAGEMENT ON SITE ACTION GROUP- RESPONSIBILITIES

Group Position	Port Position	Alternative	TEL
<b>First Aid</b>	<b>Dy CMO</b>	<b>Medical Officer</b>	<b>CONTACT</b>
Maintains a list of blood groups of each employee with special reference to rare blood groups - Liaises with CMO as necessary			2666457
Sets up a casualty collection centre , Arranges first aid posts at assembly points			2582701
Arranges for adequate medicine, antidotes, oxygen, stretchers etc			
Contacts and cooperates with local hospitals and ensure that the most likely injuries can be adequately treated at these facilities e.g. burns			
Advises Incident Action Group not to be exposed to unacceptable levels of toxic exposure			
Submits reports-indent to replenish medicines, resources used			

<b>DISASTER MANAGEMENT ON SITE ACTION GROUP- RESPONSIBILITIES</b>			<b>TEL</b>
<b>Group Position</b>	<b>Port Position</b>	<b>Alternative</b>	<b>CONTACT</b>
<b>Security</b>	<b>Dy Commandant-CISF</b>	<b>Inspector CISF</b>	<b>Off tel</b>
Controls the entry of unauthorized persons and vehicles			2666579
Permits the entry of authorized personnel and outside agencies for rescues operations without delay.			2666556
Allows the entry of emergency vehicles such as ambulances without hindrances			
Ensures that all people are aware of the assembly points, where the transportation vehicles are available.			
Ensures that the people are as per the head count available with the assembly point section of that area			
Liaises with the Addl. TM for transport arrangements of the people at assemble point			
Carries out a reconnaissance of the evacuated area before declaring the same as evacuated and report to the Commandant CISF & Chief Incident controller			
Submit report to Sr.Commdt CISF copy to Chairman-Dy Chairman-Dy Conservator & Traffic Manager			

### **DISASTER MANAGEMENT ON SITE ACTION GROUP- RESPONSIBILITIES**

<b>Group Position</b>	<b>Port Position</b>	<b>Alternative</b>	<b>TEL</b>
<b>CME DEPT.</b>	<b>DY. CME</b>	<b>Exe. Engineer(M)</b>	<b>CONTACT</b>
Suggests optimal strategies for conducting emergency isolation of damaged equipment, the emergency transfer of materials etc			<b>OFFICE</b> 2582301
Provides the necessary utilities during the emergency like back up emergency generators for general lighting purposes, pumps, welding services.			2582303
Renders assistance for extricating trapped personnel by cutting structures, wires etc			
Recommends the appropriate procedures to isolate damaged units without introducing new hazards and provides resources both in terms of personnel and equipment to accomplish this			
Assess damages and provide technical assistance to determine the operability of damaged units.			
Assists in the re- entry and restoration process of the port operation.			

### **DISASTER MANAGEMENT ON SITE ACTION GROUP- RESPONSIBILITIES**

<b>Group Position</b>	<b>Port Position</b>	<b>Alternative</b>	<b>TEL</b>
<b>Civil</b>	<b>Dy.CE</b>	<b>Sup.Engr (CM)</b>	<b>CONTACT</b>
During cyclones/floods arranges sand bags & develop methodologies to control hazardous spills.			Office 2582401
Co-operate with on-site action group to conduct the clean up work during and after the disaster.			2582402
Assist in the restoration and recovery activities.			

## EMERGENCY FACILITIES

### EMERGENCY CONTROL CENTRE AT PORT CONTROL STATION

<b>EQUIPMENT</b>	<b>NOS</b>	<b>REMARKS</b>
VTMS RADAR	2	WITH BATTERY BACKUP
VHF SETS	2	WITH BATTERY BACKUP
TELEPHONES DIRECT PLUS EPABX	2	Power supply not required
WALKIE TALKIE SETS & MOBILES	8	With spare batteries
FLIP CHART WITH FELT PENS		
IDENTIFYING JACKETS AND HELMETS AND ARM BANDS		
EMERGENCY LIGHTS AND TORCHES		
PORTABLE PA/LOUD HAILER SETS		
with emergency generator-dry food & water for 72 hours		

### CENTRAL DISASTER MANAGEMENT CONTROL ROOM-

<b>EQUIPMENT</b>	<b>NOS</b>
• Emergency lights and torches	
• TV	1
• Radio	1
• Computer	1
• Scanner/Fax and Printer	1
• Telephone hotline-State Govt	1
• Telephone hotline-Ministry of Shipping	1
• Telephone-one for incoming ;second for outgoing calls	2
• Over head slide projector	1
• White board and coloured marker pens	1
• Tape recorders	1
• Walkie talkies/mobile telephone	6
• VHF sets-marine	1
• Video camera	1
• Binoculars	1
• Disaster Management Response plan	
• Table-seating	
• Tables-for equipment	
• Chairs	
• Stationary- Flip charts	

#### **INITIATION OF CENTRAL CONTROL ROOM -On Disaster level,II or III**

Chairman CoPT will decide when members of the Central Disaster Management Group will operate from their respective dept control rooms and attend joint meetings at the Central Disaster Management Control Room or when total central control room attendance is required. Whenever the Central Disaster Management centre takes over responsibilities the On Site Action Group now reports to the Central control Room.



### **FIRE FIGHTING RESOURCES**

<b>PORT FIRE FIGHTING RESOURCES –Capacity- Specs</b>	<b>nos</b>
Foam Tender (Capacity 8000L, 4500L X 2, 3000L )	4
Water Tender ( 4500L )	1
Dry powder tender ( 2000Kg)	1
Foam Generator	1
Trailer Pump 1800LPM	2
Portable pumps (275LPM & 500 LPM)	3
Foam/ Water monitor trailer (8000 LPM)	1
Ground Monitor	16
Fire Hydrants & Hoses	25
High pressure pump (500 CU.M/HR each)	6
Breathing Apparatus Sets	16
Fire suits	5
Chemical suits	3
Mobile VHF Walkie-Talkie sets	24

<b>Pollution Response Equipments</b>	<b>No</b>
Oil containment boom-harbour	500 mtr
Ocean Boom	1500mtr
Multi Skimmer ( 60 Cu.m/hr)	01 no.
Portable skimmer ( 5 TPH )	01 no.
Oil Spill Dispersant	10000 ltr
Sorbent Boom	500 mtr
Sorbent pads	2000 no.
Skimmer Vessel ( 60 TPH)	01 no.
Flex Barge (10 Ton)	04 no.

## **SECTION 7: RECOVERY**

### **GUIDELINES FOR ASSESSMENT OF TIME TO RESTORE A PORT TO NORMAL OPERATIONAL CAPABILITY AFTER A CYCLONE / EARTH QUAKE**

An analysis of past incidents and time taken for restoration of the port to operational status is a useful tool-however the interpretation of the data results will require modifications in line with the intensity/duration of the current incident and steps and resources used to mitigate the effects pre to post cyclone. The following is a guideline

<b><u>NATURE OF RESTORATION TO PORT UNITS</u></b>	<b><u>DEPTS &amp; RESOURCES USED</u></b>	<b><u>RESTORATION</u></b>
Administrative building damage	Roads & Bldg division	1-3 days
Power Supply - restore sub stations	Port Elec Divn	<2 days
Damage to tugs - floating craft	CME Dept.	2-18 days
Sunk/grounded vessels-	Salvage Efforts	1-3 weeks
Hydrographic survey channels/berths	Hydrographic Surveyor	1-3 weeks
Damaged buoys- shifting of buoys	DC-HM-Harbour works Divn I & II	4 days
Oil.Chemical Storage Tanks	Tank farms to check integrity	2 days
Road blockades-clear debris-fallen trees	Roads & Bldg dept	1 week
Repair damaged roads	Roads & Bldg dept	<1 week
Injury & infection-medical treatment	Medical Department	1 week
Flooding & stagnant water - clean drains	Public Health Divn (Civil)	3 days
Fishing harbour-survey-damaged trawlers	Fishing Harbour Divn	1-2 weeks
Civil works -sea wall- Jetty-fenders-	CE/Harbour works Divn	1 week
Electrical & mech works	Elect. & Mech. Department	1 week
Pipeline -manifolds-isolation valves	Exe. Engr, DM Divn	2 days
Spillage of chemical-Petroleum Oil products	DC-Salvage Team-Coast Guards	4 days
Damage to Mobile cranes	CME	<1 week
Checking of transit sheds, ware houses	Traffic department	3 days
Checking of quarters of port employees	CE Dept.	3 weeks
Checking and rectification of drinking water	CE Dept.	2 days

## **PART-II**

### **Hazard Specific Incident Action (IAP)**

## **SECTION 01- CARGO RELATED ACCIDENTS:**

### **A: AMMONIA GAS LEAKAGE**

The following toxic cargo are discharged in port like Ammonia gas

#### **ANHYDROUS AMMONIA      Emergency Treatment**

##### **Effects of Overexposure**

**Eye:** Tearing, edema or blindness may occur if >700ppm

**Skin:** Irritation, corrosive burns, blister formation may result. Contact with liquid may produce a caustic burn and frostbite.

**Inhalation:** Acute exposure may result in severe irritation of the respiratory tract, bronchospasm, pulmonary edema or respiratory arrest.

**Ingestion:** Lung irritation and pulmonary edema may occur.

**Extreme exposure may result in death from spasm, inflammation or edema. Brief inhalation exposure to 5,000 ppm may be fatal.**

#### **ANHYDROUS AMMONIA      Emergency Aid:**

**Remove patient to uncontaminated area**

**Eye:** Flush with copious amounts of tepid water for a minimum of 20 minutes. Eye lids should be held apart and away from eyeball for thorough rinsing.

**Skin:** Flush with copious amounts of tepid water for a minimum of 20 minutes while removing contaminated clothing, jewelry and shoes. Do not rub or apply ointment on affected area. Clothing may initially freeze to skin. Thaw frozen clothing from skin before removing.

**Inhalation:** Remove to fresh air. If not breathing, administer artificial respiration. If trained to do so, administer supplemental oxygen, if required.

**Ingestion:** If conscious, give large amounts of water to drink. May drink orange juice, citrus juice or diluted vinegar (1:4) to counteract ammonia. If unconscious, do not give anything by mouth.

**DO NOT INDUCE VOMITING!**

**SEEK IMMEDIATE MEDICAL HELP FOR ALL EXPOSURES!**

**Note to Physician** *Respiratory injury may appear as a delayed phenomenon. Pulmonary edema may follow chemical bronchitis. Supportive treatment with necessary ventilation actions, including oxygen, may warrant consideration.*

#### **Anhydrous Ammonia: Special Protection and Procedures**

##### **Respiratory Protection**

Respiratory protection approved by NIOSH/MSHA for ammonia must be used when applicable safety and health exposure limits are exceeded. For escape in emergencies, MSHA/NIOSH approved respiratory protection that consists of a full-face gas mask and canisters approved for ammonia is required.

**Eye Protection** Chemical splash goggles should be worn when handling anhydrous ammonia. A face shield can be worn over chemical splash goggles as additional protection. Do not wear contact lenses when handling anhydrous ammonia.

**Ventilation** Local exhaust should be sufficient to keep ammonia vapor to 25 ppm or less.

**Protective Equipment** - At a minimum, splash proof, chemical safety goggles, ammonia resistant, gloves (such as rubber), and ammonia-impervious clothing should be worn to prevent contact during normal loading, unloading and transfer operations and handling small spills. Face shield and boots can be worn as additional protection.

• Respiratory protection approved by NIOSH/MSHA for ammonia must be used when applicable safety and health exposure limits are exceeded. For a hazardous material release response, Level A and/or Level B ensemble including positive-pressure SCBA should be used. A positive pressure SCBA is required for entry into ammonia atmospheres at or above 300 ppm (IDLH).

**DEPARTMENTAL ACTION - AMMONIA GAS RELEASE**

DEPT	ACTION	
<b>Marine and Vessel</b>	<p><b>A-VESSEL ACTION</b>                      Sounds internal alarm &amp; contact Port Control and CFO about the status on VHF 16/15/14 and initiates the vessel response plan.                      Ceases all cargo operations and advises the loading master to close all the manifold valves &amp; disconnects hoses and consults with HM for unberthing.</p> <p><b>B- PORT CONTROL STATION</b>  <b>Radio Operator</b> informs DC-HM-TM-Comdt CISF-CFO  <b>HM</b> appraise DC about the level of the incident and activates the on-site action group and instruct all other vessel at berth to take precautions due to the leakage. Keeps tugs, launches and mooring crew stand by to shift the vessel from the berth.</p>	
<b>Fire Service</b>	<p><b>CFO</b> arrives off berth and positions themselves upwind with suitable protective clothing with face masks, gloves and breathing apparatus and coordinates with the on-site action group.</p>	
<b>Traffic</b>	<p><b>TM</b> confirms stoppage of cargo operations  <b>Shift Manager</b> shuts down discharge operations and disconnects the Chickson arm and actuates the emergency response plan.</p>	
	<p><b>HM</b> discusses with the Jetty shift Manager of and CFO and Master to ascertain the status and emergency level, if the level is II or III then informs DC of Central Disaster Management Group.</p>	
<b>E&amp;M Department</b>	<p>Ensures adequate lighting near the area and assembly areas</p>	
<b>CISF</b>	<p><b>Commdt CISF</b> cordons off area, and arranges evacuation from upwind site</p>	
<b>Medical</b>	<p><b>Dy CMO</b> of On Site Action Group keeps ambulance ready for medical treatment.</p>	
<b>Administration</b>	<p><b>Secy</b> assists to Chairman to prepare media statement &amp; reports to MOS.</p>	
<b>Marine</b>	<p><b>DC</b> to ensure that the master of the vessel gives details in the format given below and contact the agent of the vessel for compensation if the incident is due to the vessel.</p>	
	<ul style="list-style-type: none"> <li>• Name of the Vessel &amp; IMO no</li> <li>• Name of the Master</li> <li>• Call Sign/Flag/Year Built/Class</li> <li>• Port of Registry</li> <li>• Owners Name, address fax/tel</li> <li>• Charterers Name, address fax/tel</li> <li>• Name of P&amp; I Club &amp; Local Corr</li> </ul>	<ul style="list-style-type: none"> <li>• Copy of COFR &amp; oil record book</li> <li>• Date and Time of Spillagr</li> <li>• Cause of leakage</li> <li>• Location Quantity leaked</li> </ul>

**SUMMARY FLOW CHART-CONTINGENCY PLAN AMMONIA GAS LEAKAGE**

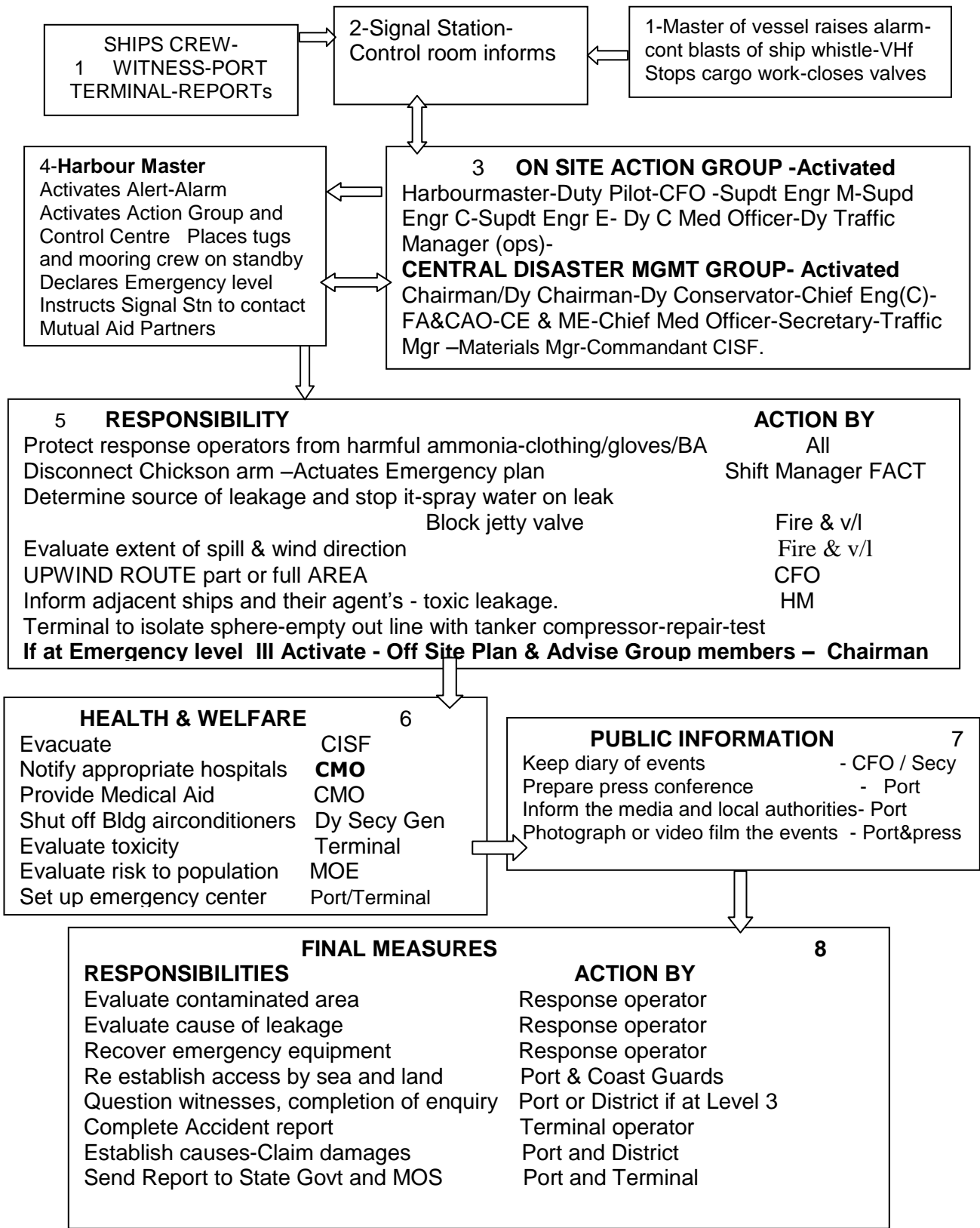

## **B: CHEMICAL/ ACID SPILLAGE**

### **PHOSPHORIC ACID EMERGENCY OVERVIEW:**

**DANGER!** Corrosive to all body tissues. Causes destruction of eye and skin tissue. Harmful if inhaled or swallowed.

### **POTENTIAL HEALTH EFFECTS:**

**INHALATION:** Corrosive to respiratory passages. May cause coughing, wheezing, Laryngitis, shortness of breath, headache, nausea.

**EYE CONTACT:** Immediate irritation and burning followed by destruction of eye tissue.

**SKIN CONTACT:** Immediate irritation and burning followed by destruction of skin tissue.

Moderately toxic when absorbed through skin. Aggravates pre-existing skin disorders.

**INGESTION:** Corrosive to gastrointestinal tract. May cause nausea, vomiting, loss of consciousness.

**CHRONIC Effects:** Kidney and liver damage possible.

### **PHOSPHORIC ACID FIRST AID MEASURES**

**INHALATION:** Remove victim to fresh air and, if needed, immediately begin artificial respiration. Give oxygen if breathing is labored. Get emergency medical help. Contact a physician immediately.

**EYE CONTACT:** Flush eyes with water for 15 minutes. Get medical attention if symptoms develop and persist.

**SKIN CONTACT:** Flush with water or soap and water for 15 minutes or until all traces have been removed. Seek medical attention if symptoms develop and persist.

**INGESTION:** Do not induce vomiting. Rinse mouth out with water. Get immediate medical attention

**SULPHURIC ACID:** Corrosive Poisonous if inhaled or swallowed. Skin contact poisonous. Contact could cause burns to skin and eyes. Fire could produce irritating or poisonous gases. Runoff from fire-control or dilution water could cause pollution. Contact with skin or eyes will cause burning dependent on concentration. Breathing high concentrations may cause coughing or sneezing. Ingestion: Serious burns of mouth.

### **EMERGENCY AND FIRST AID PROCEDURES**

**EYE CONTACT** Flush eyes with water for 15 minutes. Hold eyelids open while washing.

**SKIN CONTACT** Wash off with water. Remove clothing. Shower thoroughly. IMMEDIATELY remove contaminated clothing and drench affected area with running water for 20 minutes.

**INHALATION** Remove from contaminated area. Give oxygen. CPR if indicated. Move to fresh air.

**INGESTION:** Do not induce vomiting. Rinse mouth. Immediately give plenty of water to drink. Prompt medical attention is vital.

## **C: FIRE & EXPLOSION**

### **FIRE & EXPLOSION RESPONSE PLAN**

The CoPT Fire Fighting Service is operated by Fire Service which is headed by Chief Fire Officer is assisted by Dy. CFO, Inspectors and team which operates on a 8 hour shift round the clock. The location of the Main Fire station is near Mattancherry Gate.

#### **METHODS OF DEALING WITH DIFFERENT TYPES OF FIRES & LEAKAGE**

Fires from minor oil spillage on deck or jetty	Use dry chemical or foam extinguishers or water fog or water spray
Fire from large spillage of oil or burst hose on deck or jetty	Use large dry chemical appliance and follow up with foam or water fog/spray. Cool surrounding area/risks with water spray
Fires from spillage of oil on surrounding waters	Emulsification of oil with water jets or apply foam coverage as appropriate
Ammonia Gas	Use dry chemical, carbon dioxide, water spray or alcohol-resistant foam.from upwind position
Phosphoric/Sulphuric Acid	Dry powder, carbon dioxide (CO <sub>2</sub> ), water fog or spray
-Electrical Fires -Fire in buildings-canteen	Switch off power-use CO <sub>2</sub> or dry chemical extinguishers
Fire in office involving combustible material	Use dry powder fire extinguishers-water spray, Use Breathing apparatus.
LPG and LNG Fires	Should not be extinguished until source of leakage is under control. Dry chemical is the most effective. Cover affected area with water spray to reduce radiant heat.
Fire in cargo tanks	Use foam or steam smothering.



## DEPARTMENTAL ACTION - TANKER ON FIRE AT THE OIL JETTY

DEPT	ACTION
<b>Marine &amp; Vessel</b>	<p><b>Port Control:</b> informs HM and Chief Fire Officer the status on VHF 16/15/14.</p> <p><b>Master of the vessel</b> ceases all cargo or bunker operations close the manifold valves, disconnect hoses and consults with HM for unberthing &amp; also ensures the immediate action of the vessels Fire fighting squad.</p> <p>If necessary Master may request for additional resources and/ or-evacuation of injured.</p> <p><b>PORT CONTROL</b> Communication Officer informs CFO-DC-HM-DM-TM-Chairman-Dy Chairman, Secretary of the incident.</p> <p><b>HM:</b> Assess works together with CFO and Master to ascertain the status and crisis level. HM Informs DC of Central Crisis Management Group the status and Crisis level,places Pilots on Stand by for shifting out vessel- directs fire fighting tugs - Keeps mooring crew and launch standby to unberth vessel.</p> <p><b>DC:</b> maintains close liaison with HM and monitors progress and strategy of containment and extinguishing.</p>
<b>Fire</b>	<p><b>CFO:</b> ensures that fire tenders are ready at the jetty and takes over control from Jetty Fire Service to extinguish fire</p>
<b>Traffic</b>	<p><b>TM:</b> confirms stoppage of cargo operations to IOCL/BPCL/HPCL &amp; informs to close down the nearby berth if fire is likely to spread.</p> <p>TM monitors the situation and keeps Chairman informed about the incident.</p>
<b>Elec &amp; Mech Department</b>	<p><b>EE</b> ensures isolation of the electric power on berth.</p>
<b>CISF</b>	<p><b>Commdt CISF</b> cordons area .Executes Search and rescue with Fire.</p> <p>Keeps Commdt appraised and requests for additional resources if required.</p>
<b>Medical</b>	<p><b>Dy CMO</b> keeps ambulance standby by at berth and provides First Aid and burn treatment to the injured.</p>

## DEPARTMENTAL ACTION - FIRE AT THE GENERAL CARGO BERTHS

DEPT	ACTION
<b>Marine</b>	<p><b>Port Control station</b> informs HM and CFO the status on VHF 16/15/14 and the communication Officer at Port Control station informs CFO-DC-HM-TM-Chairman-Dy Chairman, Secretary of the incident.</p> <p><b>HM</b> activate the On Site Action group to extinguish the fire.</p> <p><b>HM</b> Informs DC of Central Crisis Management Group the status and Crisis level, places Pilots on Stand by for shifting out vessel- directs fire fighting tugs to standby ships side -Keeps mooring crew and launch standby to unberth vessel</p>
<b>Fire Service</b>	<p><b>Fire Service</b> arrives with fire tenders and resources and takes over to extinguish fire and assists in Search and Rescue operation.</p>
<b>Traffic</b>	<p><b>TM</b> ensures stoppage of cargo operations.</p> <p>If the incident is at Q10, then FACT is to be informed to initiate the on-site action group for extinguishing the fire.</p> <p><b>TM</b> of On Site ActionGroup keeps TM informed and obtains authorization to close down the nearby cargo berth if fire is likely to spread.</p> <p><b>TM</b> monitors the situation and keeps Chairman informed.</p> <p>On termination of the incident, TM monitors the early restoration of the traffic operation.</p>
<b>Elec &amp; Mech Department</b>	<p><b>EE</b> ensures isolation of the electric power on berth</p>
<b>CISF</b>	<p><b>Dy Commdt CISF</b> cordons area .Executes Search and rescue with CFO.</p> <p>Keeps Commdt appraised and requests for additional resources if required.</p>
<b>Medical</b>	<p><b>Dy CMO</b> keeps ambulance standy by at berth and provides First Aid and burn treatment to the injured.</p>

**DEPARTMENTAL ACTION - ADMINISTRATION BUILDING FIRE**

DEPT	ACTION
Administration	<p><b>First the discover</b>-Raises Alarm (breaks glass-Uses Fire extinguishers to extinguish fire and Call 102.  <b>Dy Secretary:</b> will supervise the action.  <b>Secretary</b> will be the overall incharge of the action group.                      Water should not be used for Electrical Switch Boards or on wiring as soon as an electrical fire is detected first the main switches should be put off.                      Handicapped persons should be helped to the outlet stairway which is unaffected by fire or smoke.                      Attendance register for the day and other important papers should be collected by the Administrative Officers present and taken along with them.  <b>The Sr. most Section Head on each floor</b> will be last to leave the premises and prior this person does so, he will make sure that all the electrical switches are off.                      After incident is terminated, Secretary arranges alternative office space.</p>
Fire	<p>As soon as the information is reached, the fire personnel will proceed to the floor on fire and will commence extinguishing the fire with the installed water hose and extinguishers.                      The fire service personnel will assist in transfer of sensitive documents, evacuation and shut down of equipments initiates the search and rescue operations.</p>
Civil Engineering	<p><b>Dy.CE along with the on-site group</b> survey &amp; asseses the cost to rectify the damage portion of the building.</p>
Elec & Mech Engineering	<p><b>EE</b> ensures isolation of the electric power to the administrative building.</p>
CISF	<p><b>Dy Commdt CISF</b> cordons area .Executes Search and rescue with CFO.                      Keeps Commdt apparaised and requests for additional resources if required.</p>
Medical	<p><b>Dy CMO</b> of On Site Action Group keeps ambulance standy by off Administration Building. Provides First Aid to the injured.</p>

**DEPARTMENTAL ACTION - FIRE AT CARGO STORAGE SHED**

<b>DEPT</b>	<b>ACTION</b>
<b>TRAFFIC</b>	<p><b>Shed I/c</b> raises alarm and uses Fire extinguishers to extinguish fire Call 102 (Fire). Puts the Mains switch off and informs Sr.DTM of on-site action Group and TM of Central Disaster Management Group. <b>Shed I/c</b> Mobilises all manpower in the area surrounding the site to bring the firefighting appliances in the area, to extinguish the fire. <b>The senior most Traffic official on site</b> will mobilize all the work force, labour and cargo handling appliances available in the area. <b>Sr. Dy.TM</b> ensures the removal of all the unaffected cargo from the shed to a safe place.with special reference to hazardous cargo. Details of types of cargo and quantity of cargo in the shed should be kept ready and given to of Port Fire Service who comes first to the scene of the fire. <b>Dy.TM</b> shall ensure that the labour working inside the shed is assembled for a head count.</p>
<b>Fire</b>	<p>Fire Service arrives with fire tenders and resources and takes over Fire Fighting &amp; conducts search and rescue assisted by CISF.</p>
<b>HM</b>	<p><b>HM</b> Informs DC of Central Disaster Management Group the status and Emergency leve of the incident &amp; ensures pilots are on Stand by for shifting out vessel opposite the shed if required. Also directs fire fighting tugs to spray sheds if required. Keeps mooring crew and launch standby to unberth vessel</p>
<b>Civil Engineering</b>	<p><b>Dy.CE along with the on-site group</b> survey &amp; asseses the cost to rectify the damage portion of the Cargo storage shed.</p>
<b>E&amp; M Department</b>	<p><b>Dy. CME (Ele)</b> ensures isolation of the electric power to cargo storage shed.</p>
<b>CISF</b>	<p><b>Dy Commdt CISF</b> cordons area .Executes Search and rescue with Fire Service. Keeps Commdt apparaised and requests for additional resources if required.</p>
<b>Medical</b>	<p><b>Dy CMO</b> of On Site Action Group keeps ambulance standby by off Administration Building. Provides First Aid to the injured.</p>

**D: OIL SPILL**

**DEPARTMENTAL ACTION - OIL OR CHEMICAL POLLUTION**

DEPT	ACTION		
<b>Marine and Vessel</b>	<p><b>Port Control</b> contacts <b>Dy. Conservator/ Harbour Master about the incident.</b>  <b>HM</b> Advises DC the level of emergency, Keeps tugs, pilot, mooring boats standby and oil recovery craft, tugs for dispersant.  <b>Port Control</b> informs Fishery Department of the pollution  <b>Dy Conservator</b> will inform the status to Chairman and ensures that the penalty imposed if the incident is caused by the vessels negligence is in accordance with the Major Port Trust Act. Sends notice to Master holding vessel and owners liable for the incident indicating projected expenses.  <b>The Master of the Vessel</b> will submit the oil Spill report to the Dy Conservator signed and stamped with vessels official seal in the following format.</p> <table border="1" data-bbox="358 684 1459 947"> <tr> <td data-bbox="358 684 927 947"> <ul style="list-style-type: none"> <li>• Name of the Vessel &amp; IMO no</li> <li>• Name of the Master</li> <li>• Call Sign/Flag/Year Built/Class</li> <li>• Port of Registry</li> <li>• Owners Name, address fax/tel</li> <li>• Charterers Name, address fax/tel</li> <li>• Name of P&amp; I Club &amp; Local Corr</li> </ul> </td> <td data-bbox="927 684 1459 947"> <ul style="list-style-type: none"> <li>• Copy of oil record book</li> <li>• Date and Time of Spillagr</li> <li>• Cause of Spillage</li> <li>• Location</li> <li>• Type and quantity spilled</li> <li>• Immediate action taken</li> <li>• Weather conditions</li> </ul> </td> </tr> </table>	<ul style="list-style-type: none"> <li>• Name of the Vessel &amp; IMO no</li> <li>• Name of the Master</li> <li>• Call Sign/Flag/Year Built/Class</li> <li>• Port of Registry</li> <li>• Owners Name, address fax/tel</li> <li>• Charterers Name, address fax/tel</li> <li>• Name of P&amp; I Club &amp; Local Corr</li> </ul>	<ul style="list-style-type: none"> <li>• Copy of oil record book</li> <li>• Date and Time of Spillagr</li> <li>• Cause of Spillage</li> <li>• Location</li> <li>• Type and quantity spilled</li> <li>• Immediate action taken</li> <li>• Weather conditions</li> </ul>
<ul style="list-style-type: none"> <li>• Name of the Vessel &amp; IMO no</li> <li>• Name of the Master</li> <li>• Call Sign/Flag/Year Built/Class</li> <li>• Port of Registry</li> <li>• Owners Name, address fax/tel</li> <li>• Charterers Name, address fax/tel</li> <li>• Name of P&amp; I Club &amp; Local Corr</li> </ul>	<ul style="list-style-type: none"> <li>• Copy of oil record book</li> <li>• Date and Time of Spillagr</li> <li>• Cause of Spillage</li> <li>• Location</li> <li>• Type and quantity spilled</li> <li>• Immediate action taken</li> <li>• Weather conditions</li> </ul>		
<b>Fire</b>	Fire Service arrives with sufficient man power and pollution control equipments. Fire tender kept stand by in case fire break out.		
<b>Traffic</b>	<b>Sr. Dy.TM</b> reconfirms stoppage of cargo operations to tank farmsl.		

## **SECTION 2: VESSEL ACCIDENTS**

### **A. COLLISION: PORT FLOTILLA AND VESSELS CALLING AT COCHIN PORT**

<b>SHIPBOARD-PORT EMERGENCY PLAN</b>	<b>COLLISION</b>	
<b>Action to be taken</b>	<b>ACTION BY PORT</b>	<b>ACTION BY VESSEL</b>
1. Stop the vessel and take appropriate action. 2.Sound Emergency Alarm: 3.Check for possibility of oil pollution		Master
1-Establish communication with other vessel and exchange information 2-Advise other vessels to keep clear-Hoist NUC Lights 3-Advise port for assistance 4-Advise agents of status requests surveyors-Class-P&I-Salvage association- 5-Secure evidence and maintain adequate records	HM with on-site action group.	
1-Inspects/assesses damaged area& in - case of oil leakage determine whether de-berthing of the vessels will increase oil spill rate. 2-Ascertain oil pollution-ascertain leak source 3-Harbourmaster and Master of vessel to inspect vessels 4-Sounds all bilge, ballast and fuel tanks 5-Transfer oil from leaking tanks 6-Effects damage control and temporary repairs to stop oil leakage if any with the assistance of port action group and underwater welding team or salvage group	HM with on-site action group Coast Guard + Salvage efforts	Vessel emergency action group team
1-Provides First Aid	HM + Dy.CMO.	
1-Attend engine room controls and services 2-Investigate engine room for damages and water ingress 3-Check steering gear 4-Reports status of the main engine and auxiliaries to Harbour master.		Vessel Engineering team.

## B. FIRE/EXPLOSION

<b>CHECKLIST FOR USE IN EMERGENCY</b>		
<b>SHIPBOARD EMERGENCY PLAN</b>	<b>FIRE / EXPLOSION OFF BERTH</b>	
<b>Action to be considered</b>	<b>Action taken</b>	<b>Responsibility</b>
<b>IMMEDIATE ACTION</b> Consider sounding Emergency Alarm: Initiate vessel emergency response procedure:	Yes/No Yes/No	Person discovering incident Officer on duty
<b>INITIAL RESPONSE</b> Cease all cargo and / or bunkering operation: Close manifold valves: Fire squads to position deemed best for fighting the fire: Inform terminal/loading master/bunkering personnel:	Yes/No Yes/No Yes/No Yes/No	Ch. Eng. / Officer on duty Ch. Eng./ Officer on duty Chief Engineer/ Ch.Off. Master / Officer on duty/ Chief Engineer
<b>SECONDARY RESPONSE</b> Stop air intake into accommodation: Consider to stop non-essential air intake to engine room: Determine the extent of the damage, and decide what damage control measures can be taken:  Determine whether there are casualties: Contain the fire and prevent it from spreading to other parts of the vessel: Assess health hazards from smoke: If possible, position the vessel to minimize the wind effect: Start recovering of any casualties: Notify authorities and outside organisation, as appropriate: Evaluate evacuation of non-essential crew:	Yes/No Yes/No  Yes/No  Yes/No Yes/No Yes/No Yes/No Yes/No Yes/No Yes/No	Chief Engineer Chief Engineer  Master / Chief Officer  Chief Officer  Master/Ch.Off./Ch.Engg. Ch.Off./Deck Duty heads Master Chief Officer Master Master
<b>FURTHER RESPONSE</b> Assess the possibility of pollution from leakage: Fit scupper plugs if spillage on deck: Check all tanks and compartments: Alter trim if necessary: Transfer bunker internally, if required: Require assistance as deemed necessary: Comply with reporting procedures: If required, obtain permission from local authorities and/Or the terminal to continue normal operation	Yes/No Yes/No Yes/No Yes/No Yes/No Yes/No Yes/No Yes/No Yes/No	Master/Ch.Off./Ch.Eng. Duty Off. / Dk Dutyheads Chief Officer Chief Officer Chief Officer/Ch. Eng. Master Master Master

**C. BUNKER SPILL/LEAKAGE**

<b>CHECKLIST FOR USE IN EMERGENCY</b>		
<b>SHIPBOARD OIL POLLUTION EMERGENCY PLAN</b>	<b>BUNKER SPILL/LEAKAGE</b>	
<b>Action to be considered</b>	<b>Action taken</b>	<b>Responsibility</b>
<b>IMMEDIATE ACTION</b>		
Consider sounding Emergency Alarm:	Yes/No	
Initiate vessel emergency response procedure:	Yes/No	
<b>SECONDARY RESPONSE</b>		
Consider to stop air intake into accommodation/engine room:	Yes/No	
Reduce the tank level by dropping bunker into an empty or slack tank:	Yes/No	
Assess fire risk from release of flammable substances, or health hazards from toxic substances:	Yes/No	
Prepare pumps for transfer of bunkers to shore/barge, if necessary:	Yes/No	
Prepare spillage overboard, if necessary, by adjusting ship trim:	Yes/No	
Contain spill with seals or absorbent materials:	Yes/No	
Prepare portable pumps where it is possible to transfer spill into an empty or slack tank:	Yes/No	
Check scupper plugs for tightness:	Yes/No	
Man fire station on deck if necessary:	Yes/No	
Consider notification of authorities:	Yes/No	
<b>FURTHER RESPONSE</b>		
Clean-up as required by using material from provided contingency unit:	Yes/No	
Transfer deck washing into slop tank:	Yes/No	
Ensure that residues collected in the clean-up operation are stored carefully prior to disposal:	Yes/No	
Comply with reporting procedures:	Yes/No	
If required, obtain permission from local authorities and/or the terminal to continue normal operation:	Yes/No	



## C. VESSEL GROUNDING/SINKING

### VESSEL GROUNDING IN PORT- DETAILED ACTION BY PORT

ACTION BY MARINE DEPT	DETAILS OF SPECIFIC ACTION
1-Master/Pilot	Contacts Port Control on VHF Ch 16 or Ch 14 and informs position of incident
2-Port Control	Informs HM, Dy Conservator and Coast Guard All vessels arriving and departing Cochin will be informed of the incident
3-Dy Conservator	Informs coast guard for rescue of the grounded vessel.
2-Harbour Master	Activates the on-site action group and assesses the situation, tide, wind direction, & inform DC. Through the Port Control advises all Pilots to report on duty
3- Sr. Pilot	Organises available tugs, launches, and keeps crew stand by and awaits instructions of the HM/Dy Conservator
4- Hydrographic Surveyor	Proceeds by survey launch to vessel and obtains soundings around the vessel by the echo sounder and the hand lead.
6-Master of grounded vessel	Records soundings of all tanks and also records draft, arrange soundings by hand lead around the vessel. Examines the soundings and draft around the vessel for transfer of bunkers, ballast or shift cargo to refloat vessel. Tow ropes to be kept ready
7-Master and Harbour Master	Commence preparations for towing operations 2 hours before high tide . Vessel engines to be kept stand by to assist in the refloating operations. Takes all anti oil pollution measures.
8-Port , Navy or Coast guard & Salvage efforts	Hull leakages to be attended to by under water welding by the Navy/coast guard or other available diving firms.

### SINKING OF VESSEL IN PORT

ACTION BY PORT Marine DEpt	DETAILS OF SPECIFIC ACTION	ACTION BY VESSEL
HM	<b>Ensures vessel is cleared of the channel / turning basin or berths to suitable area for normal traffic.</b>	Master activates the vessel action group
Port Control	Informs HM, Dy Conservator of the accident.	
HM and Pilots	Proceeds to the area with Tugs and conducts Rescue operations.	Lower life boats
Dy Conservator	Appriase to the Chairman and Dy Chairman and members of the Central Disaster Management group about the incident.	
HM / Navy / Coast Guard	HM to initiates the rescue operation of the person on board .	

## SECTION 3: NATURAL CALAMITIES:

### A. CYCLONE:

#### CYCLONE ALARM AND RESPONSE

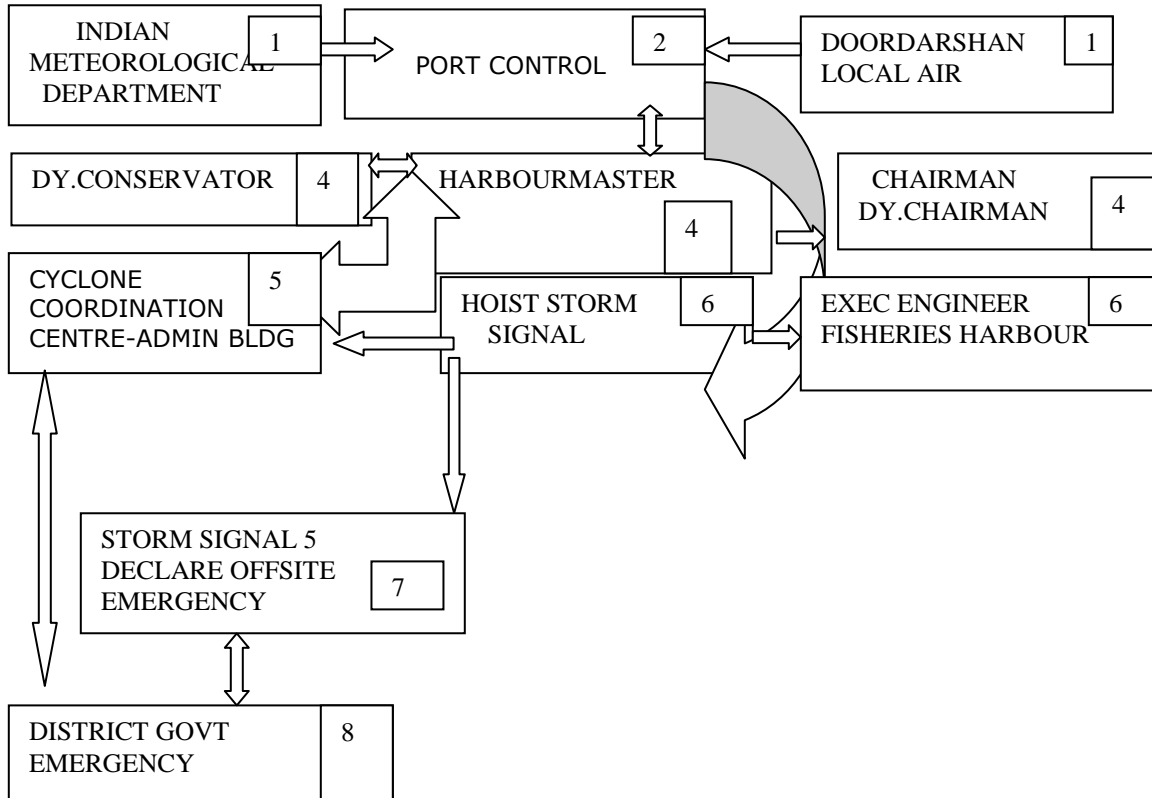

#### CLASSIFICATION OF TROPICAL DISTURBANCES OVER THE INDIAN SEAS

Classification Of Tropical Disturbances	Speed kmph	Speed knots
Low	< 31 kmph	< 17 knots
Depression	31 – 51	17 – 27
Deep Depression	52 – 62	28 – 33 kts
Cyclone	63 – 87	34 – 47 kts
Severe Cyclone	88 – 117	48 – 63 kts
Very Severe Cyclone	118 – 221	64 – 119 kts
Super Cyclone	222 kmph & above	120 kts & above

#### USEFUL WEB SITES FOR TRACKING CYCLONES

- 1- [www.imd.ernrt.in](http://www.imd.ernrt.in)
- 2- [www.supertyphoon.com/Indian.html](http://www.supertyphoon.com/Indian.html)
- 3- [www.npmoc.navy.mil/products](http://www.npmoc.navy.mil/products)
- 4- [www.solar.ifa.hawaii.edu/tropical/tropical.html](http://www.solar.ifa.hawaii.edu/tropical/tropical.html)
- 5- [www.underground.com/tropical](http://www.underground.com/tropical)

## CYCLONE CONTINGENCY PLAN:

The Cyclone Contingency Plan will come into force as soon as the storm **warning signal No.5** or higher is hoisted or when the Port organization has gathered enough data to **forecast that a cyclone threat is close.**

1. The Cyclone station will come into operation at the Signal Station.
2. The Harbour Master will be in charge of the Cyclone Station..
3. Storm warning signals will be hoisted at the Cyclone Station.
4. HM will inform the Chairman, Dy Chairman and heads of Depts by telephone/Mobile the status of worsening weather conditions and storm signals.
5. A cyclone coordination centre will be made functional in the Administrative Building headed by Secretary.
6. The Cyclone Coordination Centre will be in constant touch with Port control and District, Local Administration for rescue and relief operation.
7. All other departments to operate their respective control rooms. Port control, cyclone co-ordination centre and control rooms will function round the clock and will be closed only after obtaining the necessary orders from the Chairman.

### • MARINE DEPARTMENT

#### I - HARBOUR MASTER

Under the overall supervision and responsibility of the HM, the specific duties of marine personnel will be as below:

- **He will** be responsible for the operation of the Signal Station and will issue necessary standing orders for the purpose.
- He will keep close liaison with Radar Station, Police Wireless Station, Coast Guard and Ships in Port regarding weather conditions.
- He will prepare special signals and promulgate them to the Masters of the vessels, dredgers, tugs and any other crafts in Port. He will inform the Masters of all vessels at the berths to double the moorings, put out insurance wires and to keep engine ready to proceed out to sea if situation warrants. Decision regarding sending ships to the anchorage will be taken depending on the strength of the wind likely to be encountered and number of vessels in the Port.
- He will maintain a close liaison and co-ordination with the Marine Engineering Supt.(MES) for arranging staffs for manning the Port Crafts.

#### II- PORT CONTROL

- The staff of Port Control will remain on duty until they are relieved by next shift staff or till alternative arrangements are made or till the storm has passed or as per the HM instruction.
- Every two hour barometer reading will be recorded after cyclone warning signal No.3 is hoisted but the same will be made hourly if further upward signal is placed.
- One Aldis lamp with battery will be kept ready at signal station.
- The Port Control will maintain a continuous watch on channel 16. Port Control will keep Harbour Master informed of all the messages received by telephone, VHF sets or by messenger.

- Port Control will inform the Harbour Master of any buoys or crafts are seen adrift or any Port installation is seen or informed to be in danger.
  - a. The staff on duty will have sufficient provisions to stay on duty for a period ranging from 24 hours to 48 hours.
  - b. Port Control receiving any weather related facsimile report will pass on to the HM.
  - c. Continuous watch to be kept on CWDC. On receipt of any warning, the same shall be reported immediately to the cyclone co-ordination centre.
  - d. Port Control will be responsible to ensure that Weather messages are intimated to the Executive Engineer, in charge of Fishery Harbour on Channel 6 over VHF.

### **III. TIDAL OBSERVATORY**

The Gauge Clerk will record the range of tides, times and heights of high and low water who will in turn apprise the Dy Conservator / HM and or Sr. pilot on duty of the actual and predicted tides.

### **IV. Hydrographic Surveyor /PILOT**

The above officers will assist the HM at the Cyclone Station. One Pilot has to be kept standby to proceed on board anywhere in the Port as required.

### **V. Master Tug (Floatilla)**

- Master Tugs (Floilla) will detail one shore gang consisting of minimum one Serang, one Tindal and 10 laskars to remain on duty as emergency duty squad unit being relieved by the next shift staff or until Harbour Master instruction.
- Master Tugs (Flotilla) will take all necessary steps for the safety of the Port crafts and should ensure that all other crafts are placed at safe place and properly secured excepting one pilot launch and one stand by launch used for inspection and emergency duties.
- He along with emergency squad will make frequent round (minimum two hourly) to check the safety of Port Crafts.
- Fender and extra lengths of ropes/wires will be kept ready so as to attend to any craft whose moorings may part.
- Master Tugs (Flotilla) will inform the cyclone station immediately in the event any craft is seen adrift or any other Port installation is seen in danger.
- He will also keep a listening watch on his walkie talkie set for information.

### **VI. MASTER OF TUGS / PILOT LAUNCHES AND OTHER LAUNCHES**

- Masters of respective crafts will instruct their staff to remain on board until they are relieved by next shift staff or Sr Duty Pilot releases them from duty.
- Masters will shift their respective crafts at suitable places as directed by the Harbour Master and will secure them suitably with additional moorings. Masters of respective crafts will be responsible for proper securing and safety.
- Masters will keep the engines of their crafts ready to proceed at short notice as per the instructions Harbour Master.
- Extra fenders will be kept ready on board of the Tug for use as required.
- If any craft is seen adrift or any other port installation is seen in danger, the Master of the crafts will immediately inform the cyclone station.

The cyclone mitigation team shall be headed by Depy. C.E. & Dy C.M.E. with Engineering Supdt., DyCE (Electrical) in the control room. The Departmental vehicles as well as the hired taxis of the department shall be deployed for the above purpose.

## **PRECAUTIONARY MEASURES:**

1. Cyclone warning signals shall be communicated to all field units from the control room.
2. The field units shall communicate the signal to all the staff of the Divisions.

## **GENERAL FUNCTIONS OF FIELD UNITS**

1. All the equipment shall be properly secured.
2. Safety of workmen on duty shall be given priority during work
3. Operator's cabin doors of all the equipment and vehicles shall be kept shut.
4. Important documents/files/records at site must be stored well above the floor.

### **Main Control Room:**

- Power should be shut-off, breaker should be made-off and doors should be closed.

### **Port Electrical Division:**

- On receipt of directive from the EE , the power supply of main sub-station to be made off and communication system from control room to the sub-station to be kept operative.
- Walkie talky hand sets must be made available in all the substation for establishing communication
- Two emergency vehicles should be kept stand-by for attending to various duties.
- EE will have a temporary advance if required to meet the contingency expenditure.

### **Marine Engineering Division**

- Engine room entrance doors, sky lights etc. of all the floating crafts to be kept shut.
- All the heavy equipment and vessels must be secured in sheltered locations and operator's cabins must be kept shut.
- Special care shall be given for securing the crane boom.
- Marine Engineer Superintendent will have a temporary advance if required to meet contingency expenditure.
- Crafts are to be manned as per Marine Engineer Suptd.

### **Harbour Master Division**

- All port tugs and launches are to be secured in a safe place with good mooring ropes.
- Water tight doors, skylights, exhaust flaps have to be kept shut to avoid ingress of rain water.
- All the deck openings, sounding pipes, air vents, booby hatches etc should be shut properly.
- All the crafts have to be manned as per direction of Harbour Master.
- Harbour Master shall ensure that vesels are having adequate fuel, fresh water, provisions for at least three days.

## CIVIL ENGINEERING DEPARTMENT

### 1 - Public Health Division

Executive Engineer, Public Health Division will ensure the following:

- The staff as per usual shifts is deployed at each of pump house during cyclone.
- A sufficient quantity of bleaching powder, alum etc. and the water treatment plant is kept ready for water treatment during cyclone period.
- As soon as the contingency plan is made operational all the water tanks should be filled up and standby arrangement for supply of water to be made with special provision for the hospital.

### 2- CM (I & II) Division

The following actions will be taken:

- The Executive Engineer will post one Asst. Engineer exclusively to look after navigational aids, fenders; transit shed doors and roofs etc. along with necessary staff.
- The Executive Engineer will deploy one Asst. Engineer along with necessary staff to look after the shore protection wall condition & if any breach is noticed along the side of the shore protection wall, immediate steps should be taken up for it's repair.
- For the above purpose he shall keep ready 3,000 to 4,000 empty cements bags to be used.
- All measures to be taken to minimise uprooting of trees.

### 3 - Fishing Harbour

The CE&Administrator (CFH) should take adequate steps to protect the infrastructure of Fishing Harbour before the cyclonic weather.

## TRAFFIC DEPARTMENT

### 1- Operation

Deputy Traffic Manager (Operations) will take the following measures:

- All loading/unloading of cargo operations to be ceased.
- All the cargoes under Port's custody, lying outside and likely to get damaged, will be shifted to Transit Sheds/Ware Houses.
- Doors of the sheds will be closed and properly secured.
- He will visit the site and inspect the arrangements.

### 2- Railways

Co-ordinate with railways to ensure the following:

- Yard Master personally takes over the charge of yard supervision instead of leaving the same to shift staff.
- Movement of wagons is stopped when wind speed exceeds the operational limit (70 KM per hour).
- All the rolling stock on tracks is clamped / chained both in Port area and exchange yard and the locomotives are returned to the Loco Shed.

## ADMINISTRATION DEPARTMENT

- The Secretary will remain overall in-charge of the Cyclone Coordination Centre.
- The Secretary shall make a duty roster for the manning of the cyclone coordination centre by the officers of Administrative, Finance & Accounts and Materials Management Department.
- The Co-ordination Centre will keep constant touch with the Local & District Administration for rendering necessary assistance.
- The port Public Relations Officer will ensure announcement by the mike in the Wellington Island indicating the precautionary measures to be taken.
- The Secretary will make necessary arrangement in coordination with the local administration for evacuating people from the low lying area. They will be shifted to relief centres as designated by District Administration.
- The Secretary will hire basic transport .He will also detail Officers to remain in-charge of various relief centres.

## FINANCE & ACCOUNTS DEPARTMENT

- All the department may inform the FA&CAO Office the amount of cash required by them so that the same can be kept in advance and can be disbursed by one of the Officers of the Finance & Accounts Department as per need.

## MEDICAL DEPARTMENT

- The casualty ward is to be manned by one Specialist in addition to the regular Doctors attending.
- The Ambulance has to be kept standby near the casualty ward.

## MATERIAL MANAGEMENT DIVISION

The Sr. Dy. Materials Manager will ensure the following:

- During cyclonic season sufficient stock of stores like Polythene, J.Hooks, screw hinges, gunny bags, tarpaulins, ropes and wires for Port Crafts, diesel oil, kerosene oil, petromax lamps, torch lights with batteries and bulbs, electrical items etc. are kept.
- All the materials which are likely to get damaged with rain are covered with tarpaulin.
- Minimum staff required to issue materials including POL are kept during emergency.

## CENTRAL INDUSTRIAL SECURITY FORCE

The Commandant, CISF will make arrangement for the following:

- To keep extra vigil on the following stores/buildings which are likely to be affected by the Cyclone.

1-Electrical sub section 2-Central Stores	3-Tanker berths 4-Cargo Berth 5-Transit Sheds	6-Ware Houses 7-Administrative Building
--	---	--

- Till normalcy is restored, arrangement will be made for thorough checks on all out-going vehicles to guard against pilferage.
- Round the clock patrolling duty shall be introduced along the electric lines to guard against the removal of copper wires which are likely to be grounded during cyclone.
- A special task force to be set up by the CISF for the rescue operation.

## GENERAL INSTRUCTIONS

- Ensure that the doors and windows are properly closed prior to leaving the office
- All important files are stored in secure cupboards

### POST CYCLONE DUTIES

- All the Heads of the Departments are required to assess the damage and submit a detailed report indicating the estimate to the Chairman. For this, a team may be formed comprising Sr.Pilot, Dy Traffic Manager, EE (Elect) EE (Mech), EE (Civil) and assisted by one representative from the Finance Department. The preliminary report is to be submitted within 48 hours and detailed report within four days from the date of normalcy.
- Hydrographic survey is to be conducted to assess the channel condition and ensure resumption of shipping as early as possible.
- In case of any small craft sunk or grounded, the same to be removed to make the channel/berth safe for navigation.. HM will detail a salvage party headed by the Master Tugs for this purpose.
- A team of Officers to be nominated by the Administrative Department to supervise the rescue and relief operation and disposal of animal carcasses in coordination with the local and District Administration.
- Preventive measures for epidemics to be taken by the Medical Department.
- All the operating systems to be attended urgently and made operational as early as possible on a war footing basis to resume operation.
- Spot tendering procedure shall be followed for repairs up to Rs.2 lakhs by the concerned Executive Engineers.
- Water supply and electricity to be given priority. The electrical cabling net work to be checked area-wise. The inspection team to be decided by the Addl. CE&ME for obtaining clearance to resume power supply.
- All damaged temporary roofed houses in the port premises will be attended to.
- The Manager Materials will nominate a team for the procurement and supply of essential materials for repair of various structures and equipment as reported.
- To assess the progress of repair works, Heads of Depts meeting will be held daily till normalcy is restored.
- Assistant Secretary /Head Assistant may prepare a list of files if damaged and report to the Heads of Depts.

## **B. FLOODS**



## ACTION PLAN FLOODS-SIMILAR TO CYCLONE

DEPT	ACTION
MARINE	<ul style="list-style-type: none"><li>• Signal Station passes weather message to HM and DC</li><li>• HM places on-site action group alert</li><li>• DC apprises Chairman of weather developments who places Central Disaster Management Group on alert if necessary.</li></ul>
Civil Engg	<ul style="list-style-type: none"><li>• Drainage system of the port i.e inside harbour area &amp; out side harbour area should be cleared.</li><li>• Trailer mounted portable Diesel pump sets to be made standby with sufficient length of hose pipes.</li><li>• Sand bags to be used around sensitive areas including water supply Pump stations, electric sub stations</li></ul>
Elec & Mech Engg	<ul style="list-style-type: none"><li>• All the outside installations and equipment shall be properly secured.</li><li>• Cyclone field units to be made alert</li></ul>
Administration	<ul style="list-style-type: none"><li>• To make standby arrangements for transportation to evacuate population in low lying areas to cyclone centres and relief centres &amp; arrange food and water.</li></ul>

## C. EARTH QUAKE

### ACTION PLAN- EARTHQUAKE

#### **EARTHQUAKE PREDICTIONS**

**Local earthquake are difficult to predict Cochin is in Seismic Zone 1& 2 (lowest risk) which is quite safe as compared to Gujarat which is in zone 4 & 5(highest risk)**

- Frequency of tremors as reported in the newspapers, TV and radio
- Rattling of doors and windows on high storied building
- Unusual barking of dogs and zoo animals-notably elephants
- Falling of old and weak structures

#### **CHARACTERISTICS-QUAKE**

- Magnitude
- Focal depth
- location of quake center
- Rupture length
- Rupture orientation

#### **PROPERTY-characteristics**

- Distance from focus
  - Soil conditions
  - Geology
- Are buildings constructed to
- resist lateral forces
  - bend rather than break
  - resist sway
  - are foundations in sandy soil

### RELIEF WORK AFTER AN EARTH QUAKE

DEPT	ACTION
Chairman	To contact the District Collector, Relief Commissioner, Army, Navy, Coast guards and seek assistance.
Dy Chairman	To assist the Chairman to assess relief requirements
Administration	Secretary – To arrange for food, shelter and transportation. And assist the Chairman and Dy Chairman for all relief arrangements
Elec & Mech Dept.	CME–To provide and hire if necessary, earthmoving equipments, cranes, forklifts, bull dozers, pneumatic hammers.
Civil Eng Dept.	CE to deploy engineers to direct or guide earth moving equipment and cranes to remove the debris
Traffic	TM to ensure safety of cargo in cargo sheds and at rail siding
Marine	Dy Conservator to ensure the safety of Port Marine craft and vessels alongside
CISF	Commandant CISF to organise Search and Rescue of persons trapped under debris.
Fire	To assist in Search and Rescue operation.
Medical	CMO to ensure provide of proper Medical Aid to the injured

**If you are outdoors**, find a clear spot away from buildings, trees, streetlights, and power lines. Keep lying on the ground and stay there until the shaking stops. Injuries can occur from falling trees, street-lights and power lines, or building debris.

**If you are in a vehicle**, pull over to a clear location, stop and stay there with your seatbelt fastened until the shaking has stopped. Trees, power lines, poles, street signs, and other overhead items may fall during earthquakes. Stopping will help reduce your risk. Once the shaking has stopped, proceed with caution. Avoid bridges or ramps that might have been damaged by the quake.

**Stay indoor** until the shaking stops.

## **D. TSUNAMI**

### **ACTION PLAN - TSUNAMI**

**CHARACTERISTICS-** Tsunamis are a series of enormous waves created by an underwater disturbance such as an earthquake, landslide, volcanic eruption, or meteorite. A tsunami can move about 500 miles per hour in the open ocean. Once the wave approaches the shore, it builds in height. The topography of the coastline and the ocean floor will influence the size of the wave. There may be more than one wave and the succeeding one may be larger than the one before. Drowning is the most common cause of death associated with a tsunami. Tsunami waves and the receding water are very destructive to structures .



#### **WARNING/CONFIRMATION**

Met. Station  
COAST GUARDS  
TV and Radio News

<b>DEPT</b>	<b>ON SITE ACTION GROUP</b>
MARINE	HM through Signal Station informs all the ship to evacuate from the berth to open sea. Signal Station keeps in touch with all vessels on VHF
	Harbour Master to move tugs and launches to safe areas or deep water anchorages Crew to wear life jackets
ADMINISTRATION	Dy Secy to arrange transport to evacuate to safer inland areas
TRAFFIC	Dy. TM ensures stoppage of all cargo operations of vessels.
Civil Engineering Department	Addl CE to ensure sand bags is kept ready.
Elec & Mech Department	Addl. CE&ME to ensure proper secure of the cargo handling equipment and the shore cranes.

	<b>CENTRAL DISASTER MANAGEMENT GROUP</b>
Chairman	Activates Central Disaster Management Group
Marine	DC to apprise the group leader of the Central Disaster Management Group of any developments and early warning Systems.
Administration	Secretary to keep in constant touch with state Govt.

# SECTION -4: SECURITY THREATS

## A. BOMB THREATS

### ACTION PLAN- BOMB THREATS

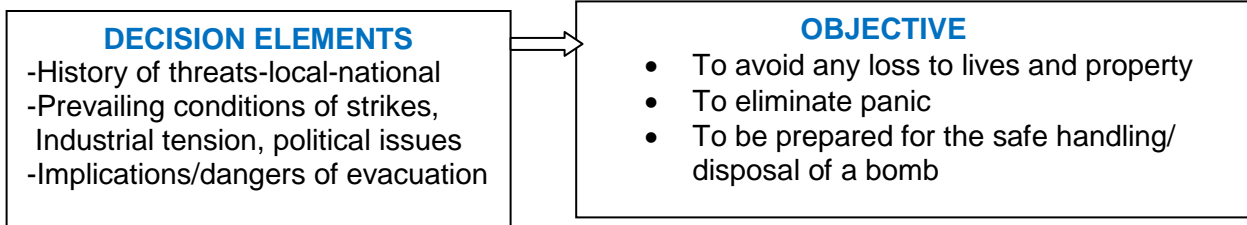

Dept	Action
CISF Security	1-Commdt CISF reports that Bomb Threat received by staff/outsider
	2-Recomends emergency classification II or III to chairman
	3-Requisitions of fire tender and ambulances and positioning them at a safe distance from the threatened or suspected area.
	4-Ensures evacuation of the workmen working inside the port area, if the threat is inside the prohibited area.
	5-Requisitions of BDDS(Bomb Detection & Disposal Squad) from Police Dept.

### Checklists-Questions to Ask Bomb Threat Caller

- Threat received in writingtelephone.
- On phone, keep caller on line as long as possible.
- Ask colleague to inform security to trace call-tape recorder.
- Ask for bomb location? time of detonation?  
 What type of a bomb?  How does it look?  
 How do you know so much about bombs?
- Advise caller of the loss of innocent lives as a consequence of a bomb detonation.  
Could he live with this guilt for the rest of his life  
Whom does he represent? Why is he doing this?
- Background Noises music,airportrailway factorytel. booth Residence-to trace place of call
- Check voice characteristics; Male Female Voice Quality-Calm excited Anger
- Age Accent-local out of state foreign disguised  
 Speech Impediment stammer slow educated  
 laughing deliberate familiar.
- Provide above details through Dept head to CISF Security

## **B. WAR ALERT**

<b>DEPT</b>	<b>ACTION</b>
PRESIDENT & PM	DECLARATION OF WAR
CHAIRMAN	1. TO ACTIVATE CENTRAL DISASTER MANAGEMENT GROUP AND ON SITE ACTION GROUP 2. CONTACT AND COORDINATE WITH CISF, INDIAN NAVY, COAST GUARDS & INDIAN ARMY
CISF	COMMANDANT CISF  Implements blackout in port
MARINE	<b>HM-</b> 1. Ensures all vessels at anchorage to observe blackout 2. No night movements <b>PORT CONTROL</b> The Sr. Pilot ensures proper following of the Naval Instructions to inbound vessels.
TRAFFIC	DTM ensures shut down of all cargo operations after sunset. Ensure workers within perimeter of dangerous/chemical tank farms shifted to safer perimeters All other workers to move out of port prohibited area during night.
ELEC & MECH Dept.	<b>CME to</b> ensure in keeping essential services working during day and night.
MEDICAL	<b>Deputy Chief Medical Officer</b> to ensure ambulances and first aid staff kept in readiness on 24 hour basis
FIRE	ON ALERT TO ASSIST CISF

## **SECTION 5- LOCAL STRIKE PLAN**

### **Strike Contingency:**

Major Ports represent a critically important asset of India's national economy. The working of ports & harbours requires certain key/essential services to be maintained. Ministry of Defence have issued a directive of contingency planning for Port's strike which has been communicated to the Port Trusts in Ministry of Transport, Department of Surface Transport (Ports Wing)'s letter No. PW/PTS-19/84 dated 01.07.1986. As per this directive the Armed Forces may be requested to render assistance as required by the Port authorities after the following conditions have been fulfilled:-

- a. The strike is declared illegal by the Central Government.
- b. All other avenues for making alternative arrangements have been fully explored by the Central Government and not found practicable.
- c. The situation created as a result of the strike is so serious as to adversely affect the national interest.
- d. A Gazette Notification is issued by the Ministry of Defence invoking sub-section (I) of Section 2 of the Armed Forces (Emergency Duties) Act, 1947 declaring services in the affected Port or Ports as essential.
- e. Normally, the assistance will be limited to the resources of the local Naval Officer-In-Charge.

### **Envisaged Tasks:**

#### **Navigation:**

The shipping operation will be carried out from 0600 to 1800 hrs. VTMS/ Port Control will operate as the Control Room and will be manned by the HM/ Pilot. HM Office may be used as alternative. Pilotage duties will be done by the Pilots. Deputy Conservator will remain over all in-charge of the operation.

The manpower requirement for the Floating Crafts & Marine Site Office will be as follows:-

Hired Tugs (2 nos)	Full complement
Pilot Launch	Normal complement
Mooring Launch	Normal complement
Standby Pilot Launch	
Standby Mooring Launch	

Employees those are not interested for taking part in the strike and willing for working during that period will be provided required protection.

Boat service to be provided from NTB jetty and Vypeen jetty for staff coming to Administration block and Mooring shed.

**The areas where assistance of navy would be required as per the directive of the Ministry of defence are enumerated as follows:**

:

- Maintenance of pilot services/pilotage.
- Berthing, unberthing, mooring and unmooring of vessels.
- Manning and operation of pilot launches, mooring boats, tugs and other auxiliary crafts.
- Operation of Port Signal Stations.
- The manpower requirement for this purpose is as follows :-

**Floating Crafts & Marine Site Office:**

- CISF provide security & transport to Port Trust Pilots to carry out Pilotage of vessels.
- Hired tugs to be secured at safe berth with adequate protection to crew.
- The tug and pilot launch will work in general shift and Mooring Launch in three shifts.
- All vessels should be properly locked to avoid sabotage.

**Security of Port Trust Installations, Cargo & Personnel:**

As per the directive, the State Police/CISF must ensure the security of the Port Trust property & personnel involved in rendering assistance.

**The CISF shall ensure:**

- Security of Port property, cargo and personnel.
- Security of personnel involved in rendering assistance.
- Fire fighting services of the Port Trust.

**APPENDIX A - MOS/OFF SITE-MUTUAL AID TELEPHONE NUMBERS**

<b>MINISTRY OF SHIPPING</b>	<b>OFFICE TEL</b>	<b>RES TEL</b>	<b>WEB SITE- FAX NO</b>
Transport Bhavan, 1 Sansad Marg New Delhi 110 001			<a href="http://www.shipping.nic.in">www.shipping.nic.in</a> Fax 23715118
Minister	011-23710121	23359111	
PS (Minister)	23711252	23321010	Fax 23715118
Secretary Ministry of Shipping	23714938	24674955	Telefax 23716656
Adll Sey & Financial Advisor	23710140	26898958	
Joint Secy (P)	23711873		
<u>Dredging Corp of India Limited</u>			<a href="http://www.dredge-india.com">http://www.dredge-india.com</a>
Directorate General Shipping	91-22-22613651	Fax. -22613655	<a href="mailto:dgship@dgshipping.com">dgship@dgshipping.com</a>
<u>Indian Ports Association</u>			<a href="http://www.ipa.nic.in">www.ipa.nic.in</a>
<u>Tariff Auth Major Ports (TAMP)</u>			<a href="http://www.tariffauthority.gov.in">www.tariffauthority.gov.in</a>
National Maritime Academy	24530343/44/ 45	Fax 044-24530342	<a href="http://www.nipm.in.nic.in">www.nipm.in.nic.in</a>
<b>OFF SITE GROUP</b>	<b>Office Tel</b>	<b>RES TEL</b>	<b>Address</b>
National Disaster Managemnt Group	011-25655014	Fax-011-25655003	New Delhi
<b>District Collector</b>	484-2423001	484-2372902	<b>Kochi</b>
Dy. Collector/ADM	484-2422282		Kochi
RDO Fort Kochi	484-2215340		Fort Kochi
Commissioner of Police	9497996990		
Dy. Commisioner L&O	9497996986		
Mayor	484-2369007		
Dy. Mayor	484-2362707		



## APPENDIX B- SAFETY DATA SHEET, AMMONIA

### ANHYDROUS AMMONIA: (MSDS) Material Safety Data Sheet

#### Description

**Chemical Name:** Ammonia, Anhydrous

**CAS Registry No:** 7664-41-7 **Identification No:** UN 1005

**Synonyms:** Ammonia

**Chemical Family:** Inorganic Nitrogen Compound

**Formula:** NH<sub>3</sub>

**Molecular Weight:** 17.03 (NH<sub>3</sub>)

**Composition:** 99+% Ammonia

#### Statement of Health Hazard Hazard Description

Ammonia is an irritant and corrosive to the skin, eyes, respiratory tract and mucous membranes. Exposure to liquid or rapidly expanding gases may cause severe chemical burns and frostbite to the eyes, lungs and skin. Skin and respiratory related diseases could be aggravated by exposure.

#### Emergency Treatment

#### Effects of Overexposure

**Eye:** Tearing, edema or blindness may occur if >700ppm

**Skin:** Irritation, corrosive burns, blister formation may result. Contact with liquid may produce a caustic burn and frostbite.

**Inhalation:** Acute exposure may result in severe irritation of the respiratory tract, bronchospasm, pulmonary edema or respiratory arrest.

**Ingestion:** Lung irritation and pulmonary edema may occur. **Extreme exposure may result in death from spasm, inflammation or edema. Brief inhalation exposure to 5,000 ppm may be fatal.**

#### Emergency Aid: Remove patient to uncontaminated area

**Eye:** Flush with copious amounts of tepid water for a minimum of 20 minutes. Eyelids should be held apart and away from eyeball for thorough rinsing.

**Skin:** Flush with copious amounts of tepid water for a minimum of 20 minutes while removing contaminated clothing, jewelry and shoes. Do not rub or apply ointment on affected area. Clothing may initially freeze to skin. Thaw frozen clothing from skin before removing.

**Inhalation:** Remove to fresh air. If not breathing, administer artificial respiration. If trained to do so, administer supplemental oxygen, if required.

**Ingestion:** If conscious, give large amounts of water to drink. May drink orange juice, citrus juice or diluted vinegar (1:4) to counteract ammonia. If unconscious, do not give anything by mouth.

#### DO NOT INDUCE VOMITING!

#### SEEK IMMEDIATE MEDICAL HELP FOR ALL EXPOSURES!

**Note to Physician** *Respiratory injury may appear as a delayed phenomenon. Pulmonary edema may follow chemical bronchitis. Supportive treatment with necessary ventilation actions, including oxygen, may warrant consideration.*

#### Special Fire-Fighting Procedure

Must wear protective clothing and a positive pressure SCBA. Stop source if possible. If a portable container (such as a cylinder or trailer) can be moved from the fire area without risk to the individual, do so to prevent the pressure relief valve of the trailer from discharging or the cylinder from rupturing. Fight fires using dry chemical, carbon dioxide, water spray or alcohol-resistant foam. Cool fire exposed containers with water spray. Stay upwind when containers are threatened. Use water spray to knock down vapor and dilute

**Extinguishing Media:** Dry Chemical, CO<sub>2</sub>, water spray or alcohol-resistant foam if gas flow cannot be stopped

**Fire and Explosion Hazard Data** **Flashpoint:** None

**Flammable Limits in Air:** LEL/UEL 16% to 25% (listed in the NIOSH Pocket Guide to Chemical Hazards 15% to 28%) **Auto Ignition Temperature:** 1,204°F (If catalyzed), 1,570°F (If un-catalyzed)

#### Unusual Fire and Explosion Hazards

- Outdoors, ammonia is not generally a fire hazard. Indoors, in confined areas, ammonia may be a fire hazard, especially if oil and other combustible materials are present. Combustion may form toxic nitrogen oxides.
- If relief valves are inoperative, heat exposed storage containers may become explosion hazards due to

over pressurization.

### **Chemical Reactivity Stability**

Stable at room temperature. Heating a closed container above room temperature causes vapor pressure to increase rapidly. Anhydrous ammonia will react exothermically with acids and water. Will not polymerize

### **Conditions to Avoid**

Anhydrous ammonia has potentially explosive reactions with strong oxidizers. Anhydrous ammonia forms explosive mixtures in air with hydrocarbons, chlorine, ethanol, fluorine and silver nitrate. Anhydrous ammonia reacts to form explosive products, mixtures or compounds with mercury, gold, silver, iodine, bromine and silver oxide. Avoid anhydrous ammonia contact with chlorine, which forms a chloramine gas, which is a primary skin irritant and sensitizer. Avoid anhydrous ammonia contact with galvanized surfaces, copper, brass, bronze, aluminum alloys, mercury, gold and silver. A corrosive reaction will occur.

### **Spill or Leak Procedures**

### **Steps to be Taken**

Stop source of leak if possible, provided it can be done in a safe manner. Leave the area of a spill by moving laterally and upwind. Isolate the affected area. Non-responders should evacuate the area, or shelter in place. Only properly trained and equipped persons should respond to an ammonia release. Wear eye, hand and respiratory protection and protective clothing; see

**Protective Equipment.** Stay upwind and use water spray downwind of container to absorb the evolved gas. Contain spill and runoff from entering drains, sewers, and water systems by utilizing methods such as diking, containment, and absorption. CAUTION: ADDING WATER DIRECTLY TO LIQUID SPILLS WILL INCREASE VOLATILIZATION OF AMMONIA, THUS INCREASING THE POSSIBILITY OF EXPOSURE.

### **Special Protection and Procedures**

#### **Respiratory Protection**

Respiratory protection approved by NIOSH/MSHA for ammonia must be used when applicable safety and health exposure limits are exceeded. For escape in emergencies, MSHA/NIOSH approved respiratory protection that consists of a full-face gas mask and canisters approved for ammonia is required.

**Eye Protection** Chemical splash goggles should be worn when handling anhydrous ammonia. A face shield can be worn over chemical splash goggles as additional protection. Do not wear contact lenses when handling anhydrous ammonia.

**Ventilation** Local exhaust should be sufficient to keep ammonia vapor to 25 ppm or less.

**Protective Equipment** • At a minimum, splash proof, chemical safety goggles, ammonia resistant, gloves (such as rubber), and ammonia-impervious clothing should be worn to prevent contact during normal loading, unloading and transfer operations and handling small spills. Face shield and boots can be worn as additional protection. Totally-encapsulated chemical protective suit (TECP suit)" means a full body garment which is constructed of protective clothing materials; covers the wearer's torso, head, arms, legs and respirator; may cover the wearer's hands and feet with tightly attached gloves and boots; completely encloses the wearer and respirator by itself or in combination with the wearer's gloves, and boots

• Respiratory protection approved by NIOSH/MSHA for ammonia must be used when applicable safety and health exposure limits are exceeded. For a hazardous material release response, Level A and/or Level B ensemble including positive-pressure SCBA should be used. A positive pressure SCBA is required for entry into ammonia atmospheres at or above 300 ppm (IDLH).

**Physical Data Boiling Point:** -28°F at 1 atm **pH:** N/A **Specific Gravity of Gas (air = 1):** 0.596 at 32°F

**Specific Gravity of Liquid (water = 1):** 0.682 at -28°F (compared to water at 39°F)

**Percent Volatile:** 100% at 212°F **Appearance and Odor:** Colorless liquid or gas with pungent odor

**Critical Temperature:** 271.4°F **Gas Specific Volume:** 20.78 Ft<sup>3</sup>/lb at 32°F and 1 atm

**Vapor Density (air = 1):** 0.0481 Lb/Ft<sup>3</sup> at 32°F **Liquid Density:** 38.00 Lb/Ft<sup>3</sup> at 70°F

**Approximate Freezing Point:** -108°F **Weight (per gallon):** 5.15 pounds at 60°F

**Vapor Pressure:** 114 psig 70°F

**Solubility in Water (per 100 pounds of water):** 86.9 pounds at 32°F, 51 pounds at 68°F

**Surface Tension:** 23.4 Dynes / cm at 52°F **Critical Pressure:** 111.5 atm

HEALTH = 3      FLAMMABILITY = 1      REACTIVITY = 0      PERSONAL PROTECTION = H

**Waste Disposal** Classified as Hazardous Waste due to corrosivity with designation D002, if disposed of in original form. Suitably diluted product may be disposed of on agricultural land as fertilizer if permitted by local and National Regulations.. Keep spill from entering streams, lakes, or any water systems

## APPENDIX C- SAFETY DATA SHEET (PHOSPHORIC ACID) (CAS# 7664-38-2)

### TRANSPORTATION INFORMATION

PROPER SHIPPING NAME: Corrosive liquid, n.o.s., (phosphoric acid, hydroxyacetic acid), 8, UN 1760, PG III

**HAZARD CLASS:** 8 **IDENTIFICATION NO:** UN 1760 DOT Emergency Guide #154

Reportable Quantity (RQ): 1000 gallons (phosphoric acid)

International: Corrosive liquid, n.o.s., (phosphoric acid, hydroxyacetic acid), 8, UN 1760, PG III, IMDG

### HAZARDS IDENTIFICATIONS

**EMERGENCY OVERVIEW: DANGER!** Corrosive to all body tissues. Causes destruction of eye and skin tissue. Harmful if inhaled or swallowed.

#### POTENTIAL HEALTH EFFECTS:

**INHALATION:** Corrosive to respiratory passages. May cause coughing, wheezing, laryngitis, shortness of breath, headache, nausea.

**EYE CONTACT:** Immediate irritation and burning followed by destruction of eye tissue.

**SKIN CONTACT:** Immediate irritation and burning followed by destruction of skin tissue.

Moderately toxic when absorbed through skin. Aggravates pre-existing skin disorders.

**INGESTION:** Corrosive to gastrointestinal tract. May cause nausea, vomiting, loss of consciousness.

**CHRONIC Effects:** Kidney and liver damage possible.

### FIRST AID MEASURES

**INHALATION:** Remove victim to fresh air and, if needed, immediately begin artificial respiration. Give oxygen if breathing is labored. Get emergency medical help. Contact a physician immediately.

**EYE CONTACT:** Flush eyes with water for 15 minutes. Get medical attention if symptoms develop and persist.

**SKIN CONTACT:** Flush with water or soap and water for 15 minutes or until all traces have been removed. Seek medical attention if symptoms develop and persist.

**INGESTION:** Do not induce vomiting. Rinse mouth out with water. Get immediate medical attention

### FIRE FIGHTING MEASURES

FLASHPOINT (TEST METHOD): NA

FLAMMABLE LIMITS: LOWER: NA UPPER: NA

AUTOIGNITION TEMPERATURE: NA

#### GENERAL HAZARD:

**FIRE FIGHTING INSTRUCTIONS:** Approach fire from upwind side. Avoid breathing smoke, fumes, mist, or vapors on the downwind side. Firefighters wear protective clothing and self contained breathing apparatus.

**EXTINGUISHING MEDIA:** Dry powder, carbon dioxide (CO<sub>2</sub>), water fog or spray.

**HAZARDOUS COMBUSTION PRODUCTS:** Smoke, CO, CO<sub>2</sub>, toxic fumes of PO<sub>x</sub>

### ACCIDENTAL RELEASE MEASURES

**LAND SPILL:** Emergency response coordinator must have mandated training. Eliminate all ignition sources. **SMALL SPILLS:** Pick up with absorbent materials and place in non-leaking containers; seal tightly for proper disposal or reuse. **LARGE SPILLS:** Evacuate the hazard area of unprotected personnel. Wear appropriate respirator and protective clothing. Shut off source of leak if safe to do so. Dike and contain. Remove with vacuum trucks or pump to storage/salvage vessels. **WATER SPILL:** Notify proper authorities. Clean up spills/leaks immediately to prevent soil or water contamination

### HANDLING AND STORAGE

**HANDLING:** Always add acid to water; never water to acid. Avoid contact with skin, eyes, and clothing. After handling this product, wash hands before eating, drinking, or smoking. If contact occurs, remove contaminated clothing. If needed, take first aid action shown in section IV. Launder contaminated clothing before reuse.

**STORAGE:** Store away from caustic / alkalies

### EXPOSURE CONTROLS/PERSONAL PROTECTION

**ENGINEERING CONTROLS:** Local exhaust recommended.

**PERSONAL PROTECTION:** Use NIOSH approved respirator, chemical impervious gloves, chemical goggles or full face shield. Use boots, aprons, drench showers, eye wash as needed for protection against spills and/or splashes

### ECOLOGICAL INFORMATION

Dangerous to aquatic life in high concentrations. Phosphoric acid 138 ppm / 24 hr. / mosquito fish / TLm / fresh water

### - DISPOSAL CONSIDERATIONS

Dispose as hazardous waste. Classification and documentation is required before disposal. Follow all local, state and Central Govt laws and regulations.

### PHYSICAL AND CHEMICAL PROPERTIES

**VAPOR PRESSURE** (Air=1): Same as H<sub>2</sub>O

**SPECIFIC GRAVITY:** 1.2

**SOLUBILITY IN WATER:** Soluble

pH: 1 - 2

**BOILING POINT:** 130 C

**VAPOR DENSITY** (Air=1): 1.0

**EVAPORATION RATE** (BuAc=1): >1

**VOC** (G/L): 0

**FREEZING POINT:**

**APPEARANCE & ODOR:** Colorless liquid, no odor

### STABILITY AND REACTIVITY

**STABILITY:** Stable.

**CONDITIONS TO AVOID:**

**MATERIALS TO AVOID:** Alkaline materials, caustics.

**HAZARDOUS DECOMPOSITION PRODUCTS:** From combustion: smoke, CO, CO<sub>2</sub>, PO<sub>x</sub>

**HAZARDOUS POLYMERIZATION:** Will not occur.

### TOXICOLOGICAL INFORMATION

Phosphoric acid

LDLo: 220 mg/kg (unr - man)

LD50: 1530 mg/kg (oral - rat)

LD50: 2740 mg/kg (skin - rat)

Hydroxyacetic acid

LD50: 1950 mg/kg (oral - rat)

2 mg SEV (eye - rabbit)

NFPA Ratings Health:2







Flammability: 0



Reactivity: 0

HMIS Protective Equipment: X

**APPENDIX D-STROM SIGNALS**

**STORM WARNING SIGNALS**

SIGNAL NO.	DESCRIPTION	ACTION
DAY-NIGHT I  ○	<b>DISTANT CAUTIONARY :</b> There is a region of squally weather in which a storm may be forming.	Monitor weather report, TV news Internet and keep close watch.
II  ○	<b>DISTANT WARNING :</b> A storm has formed.	Monitor weather report, TV news, Internet and keep close watch inform all.
III.  ○	<b>LOCAL CAUTIONARY :</b> The Port is threatened by squally weather.	Inform all. Warn fishermen
IV.  ○	<b>LOCAL WARNING :</b> The Port is threatened by a storm but it does not appear that the danger is as yet sufficient great to justify extreme measures of precaution.	Alert all concerned to be ready and available.
V.  ○	<b>DANGER :</b> The Port will experience weather from a storm of slight or moderate intensity that is expected to cross the Coast to the South of the Port	Implement Contingency Plan.
VI,  ○	<b>DANGER :</b> The Port will experience severe weather from a storm of slight or moderate intensity that is expected to cross the Coast to the North of the Port.	Implement Contingency Plan.

VII.  ○	<b>DANGER :</b> The Port will experience severe weather from a storm of slight or moderate intensity that is expected to cross the Coast over or near to the Port.	Implement contingency Plan.
 ○		
 ○		
	<b>NOTE:</b> this signal is also hoisted when a storm is expected to skirt the Coast without (actually) crossing it.	

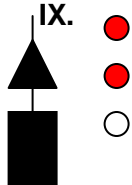
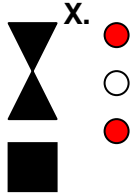
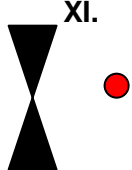
SIGNAL NO. DAY-NIGHT	DESCRIPTION	ACTION
<p>IX. </p> <p>X. </p> <p>XI. </p>	<p><b>GREAT DANGER :</b> The Port will experience severe weather from a storm of greater intensity that is expected to cross the Coast to the North of the Port.</p> <p><b>GREAT DANGER :</b> The Port will experience severe weather from a storm of great intensity that is expected to cross over or near the Port.</p> <p><b>NOTE :</b> This signal is also hoisted when a severe storm is expected to skirt the Coast without (actually) crossing it.</p> <p><b>FAILING OF COMMUNICATION :</b> Communications with the Meteorological Warning Centre have broken down and the local Officer considers that there is danger of bad weather.</p> <p><b>NOTE :</b> Squally weather is meant to cover occasional/frequent squalls with rain or persistent type of storage gusty winds (mean wind speed not less than 20 knots) accompanied by rain. Such conditions are associated with low pressure systems or onset strengthening of monsoon. Mean wind speeds exceeding 33 knots associated with cyclonic storms are generally covered by signal higher than LC.III. The word generally has been added to permit hoisting of LC.III at Ports outside the inner storm area where wind speeds may exceed 33 knots.</p>	<p>Implement contingency Plan.</p> <p>Implement contingency Plan.</p>

## **APPENDIX E – TERMS AND DEFINITIONS**

### **Terms and Definitions:**

**On-Site Plans** address incidents originating within the port area whereas **Off-Site Plans** address incidents originating outside the port area but affecting the port operations or from port to outside

**Risk** is defined as the chance of an adverse event occurring in some period of time or in a specific circumstance, in the process of engaging in an activity

**A hazard** is a phenomenon which may cause disruption to persons and their infrastructure;

and is an undesirable outcome in the process of engaging in an activity

**Disaster** - An event which can cause immense damage and disruption to the (Port and its) infrastructure causing loss to lives and property;

An **Emergency** is a serious sudden situation or occurrence that happens unexpectedly and demands immediate action to correct or to protect lives and/or property.

**A Crisis** is an unstable situation of extreme danger and may lead to the following elements; - Surprise- -Rapid flow of events-Lack of or insufficient information-Internal conflict-confusion

**Disaster Management** is a set of actions and processes designed to lessen disastrous effects before, during and after a disaster.

**Preparedness** are those measures undertaken in advance to ensure that individuals and agencies will be ready to react, such as emergency plans, logistical support and resource, inventories, and emergency information & communications systems

**Response** - Those measures undertaken immediately after a disastrous or hazardous event has occurred and for a limited period of time thereafter, primarily to save human life, property, treating the injured, prevent further injury and other forms of property loss and to mitigate disruption. They include response plan activation, declaration and communication of emergency to the concerned potential population and facilities at risk, opening and staffing of emergency operation centres, mobilization of resources, issuance of warnings and directions and provision of aid.

**Mitigation** - Those measures and activities aimed at reducing or eliminating hazards or lessening the impact of the event.**Prevention** - Mitigation of hazard effects through public education, early warning or detection systems, safety systems, building and land-use codes and regulation,

**Recovery** - Those measures undertaken to restore normal conditions. The time frame for recovery begins as soon as a reduction in critical response activities permits the re-allocation of resources and could include physical restoration and reconstruction.