

To,

Bureau of Energy Efficiency  
Ministry of power, Government of India  
4<sup>th</sup> Floor, Sewa Bhawan  
R.K Puram,  
New Delhi-110066

Subject: Energy Audit report of Cochin Port Authority (CoPA)

Dear Sir,

Please find here with the energy Audit report of Cochin Port Authority (CoPA) prepared as per the Bureau of energy efficiency regulations for manner and intervals for conduct of energy audit in electricity distribution companies ( Vide Bureau of energy efficiency notification dated 6<sup>th</sup> Oct 2021).

The Energy Audit report is for the Financial Year 2021-22.

T.N Agrawal  
Accredited Energy Auditor (AEA-0089)  
Greenserve Energy Management solutions,  
Durg

Ajayakumar RS- Exe Engineer(Elec)  
Nodal Officer,  
Cochin Port Authority (CoPA)

# Annual Energy Audit Report (FY21-22)



कोचिन पत्तन प्राधिकरण  
Cochin Port Authority

## Cochin Port Authority

Willingdon Island, Kochi,  
Kerala 682009

PREPARED BY

Greenserve Energy Management solutions

Vijay Nagar, Near Shrinathkunj

Durg-491001



SUBMITTED TO



# Annual Energy audit report of Cochin Port Authority (2021-22)

## Quality Control

<b>LOI No</b>		<b>Doc type.</b>	<b>Energy Audit report</b>
<b>Project</b>	Annual Energy Audit of Cochin port Authority (2021-22)		
<b>Location</b>	Cochin		
<b>File name</b>	Annual Energy Audit of Cochin port Authority (2021-22)		
<b>Date</b>	07/09/2022		
<b>Prepared by</b>	Ponraja	Signature (for file)	
<b>Reviewed by</b>	T.N Agrawal	Signature (for file)	

## Revision Schedule

<b>Revision no</b>	<b>Revision Date</b>	<b>File name</b>
<b>1</b>	9/10/2022	Annual Energy Audit of Cochin port Authority (2021-22)
<b>2</b>	12/10/2022	Annual Energy Audit of Cochin port Authority (2021-22)

## Declaration:

The statements, recommendations and views expressed in this report are solely at the discretion of GEMS. The data provided in this report are provided either by the project proponent or collected during site studies and is represented undistorted of any form.

# Annual Energy audit report of Cochin Port Authority (2021-22)

## Contents

Acknowledgement .....	6
<b>1. Executive Summary.....</b>	<b>8</b>
<b>1.1 Energy accounts and performance of FY 2021-22 .....</b>	<b>8</b>
<b>1.1 Discom wide energy accounting.....</b>	<b>8</b>
<b>1.2 Status of metering infrastructure for energy accounting and auditing .....</b>	<b>10</b>
<b>1.3 Energy conservation measures already taken and proposed for future.....</b>	<b>15</b>
<b>2. Summary of critical analysis of energy auditor and management analysis .....</b>	<b>17</b>
<b>2.1 Compliance to BEE regulations .....</b>	<b>17</b>
<b>2.2 Feeder metering and energy audit .....</b>	<b>17</b>
<b>2.3 Category wise subsidy .....</b>	<b>17</b>
<b>2.4 Analysis on T&amp;D Losses and AT&amp;C Losses .....</b>	<b>18</b>
<b>2.5 Circle wise % Losses: .....</b>	<b>19</b>
<b>2.6 Category wise % Losses.....</b>	<b>19</b>
<b>3. Background.....</b>	<b>21</b>
<b>3.1 Extent regulations and role of bee .....</b>	<b>21</b>
<b>3.2 Purpose of audit and accounting report .....</b>	<b>24</b>
<b>3.3 Period of energy auditing and accounting .....</b>	<b>24</b>
<b>4. Project Introduction .....</b>	<b>25</b>
<b>4.1 Name and address of DISCOM.....</b>	<b>25</b>
<b>4.2 Name and details of energy manager and authorized signatory of DISCOM .....</b>	<b>25</b>
<b>4.3 Summary profile of DISCOM.....</b>	<b>25</b>
<b>4.3.1 Asset Details .....</b>	<b>25</b>
<b>4.3.2 Energy flow.....</b>	<b>26</b>
<b>4.3.3 Consumer base.....</b>	<b>26</b>
<b>4.3.4 Power supply position.....</b>	<b>27</b>
<b>4.3.5 Power Purchase.....</b>	<b>27</b>
<b>4.4 Key Projects .....</b>	<b>28</b>
<b>5. Discussion and analysis.....</b>	<b>30</b>
<b>5.1 Energy accounts for previous years .....</b>	<b>30</b>
<b>5.2 Energy accounts and performance .....</b>	<b>30</b>
<b>5.3 Critical analysis by energy auditor .....</b>	<b>34</b>
<b>5.3.1 compliance to bee regulations .....</b>	<b>34</b>
<b>5.4 Inclusion and exclusions.....</b>	<b>39</b>

# Annual Energy audit report of Cochin Port Authority (2021-22)

6. Notes of the EA/EM along with queries and replies to Data gaps .....	40
7. Recommendation .....	41
CERTIFICATION .....	46
<b>8. Annexure .....</b>	<b>47</b>
<b>8.1 Check list prepared by auditing firm.....</b>	<b>47</b>
8.2 Brief approach, scope & methodology for audit.....	51
<b>8.3 Infrastructure details.....</b>	<b>52</b>
8.4 Power purchase details .....	56
8.5 Single Line diagram .....	57
<b>8.6 Category of service details (with consumer and voltage- wise).....</b>	<b>59</b>
<b>8.7 list of documents verified with each parameter .....</b>	<b>61</b>

## List of tables:

Table 1: Energy Audit team.....	7
Table 2: Input Energy .....	8
Table 3: T&D Losses .....	8
Table 4: Category of Consumers .....	9
Table 5: Details of Consumer Category (2021-22).....	9
Table 6: Status of metering Infrastructure for energy Accounting and Auditing .....	10
Table 7: Collection efficiency of CoPA .....	19
Table 8: Circle losses .....	19
Table 9: Details of Authorized Authority .....	25
Table 10: Asset Details .....	25
Table 11: Energy Flow .....	26
Table 12: Consumer base.....	26
Table 13: Power supply to consumers .....	27
Table 14: Performance Discom .....	30
Table 15: AT&C Losses .....	33
Table 16: Category wise sales .....	33
Table 17: Critical analysis by energy auditor .....	34
Table 18: Data Gap.....	40
Table 19: Losses at Each Stage of Electricity Distribution .....	43
Table 20: Saving calculation of recommendation.....	45
Table 21: Check List for Energy Audit .....	47
Table 22: Clauses of BEE regulations .....	48
Table 23: Infrastructure details.....	52
Table 24: List of Transformers under T& Sections.....	52
Table 25: List of transformers under North end .....	53
Table 26: List of RMU's .....	55
Table 27: Power purchase details.....	56

# Annual Energy audit report of Cochin Port Authority (2021-22)

Table 28: Energy cost realized on category wise ..... 59

Table 29: List of Documents verified ..... 61

## List of Graph:

graph 1: % of Category of Consumer ..... 20

graph 2: % Consumption in MU ..... 20

## List of figures:

Figure 1:SLD of Willington Island ..... 57

Figure 2: SLD of Vallarpadam ..... 58





# Annual Energy audit report of Cochin Port Authority (2021-22)

## Acknowledgement

We are grateful to the management of **Cochin Port Authority** for giving us an opportunity to contribute in their efforts towards continual improvement steps in business sustainability through Energy Resource Management and for entrusting the work of Annual Energy Audit for FY 2021-2022 as per BEE regulations.

GEMS wishes to thank the following officials for their kind support extended during Annual Energy Audit.

1. **Mr. ThuraiPandian- CME**
2. **Mr. Ajayakumar RS- Exe. Engineer(Elec) & Nodal Officer**
3. **Mrs. Jayalakshmi S- Asst. Exe. Engineer(Elec) & Energy Manager**
4. **Mr. Mathew Paul - Asst. Engineer(Elec)**
5. **Mr. Johnny Alumparambil- Asst. Engineer(Elec)**

We take this opportunity to also thank all the team members at various departments associated with this study for extending cooperation during collection of onsite data.

We trust that the findings of this study will help the management in improving the performance at Cochin Port Authority.

# Annual Energy audit report of Cochin Port Authority (2021-22)

## Energy Audit Team

The details of Energy audit team including designation, professional qualification & experience are furnished as under:

Table 1: Energy Audit team

Sno	Name	Qualification	Designation	Exp.
1	<b>Mr. TN Agrawal</b>	<b>B.E. (Mech), PGDMM, FIE</b>	<b>Accredited Energy Auditor (AEA-0089),</b>	<b>45 Yrs.</b>
2	<b>Mr. Suresh Rambhau Ladke</b>	<b>B.E (electrical)</b>	<b>Sector Expert</b>	<b>40 yrs</b>
3	<b>MR. N.Ponraja</b>	<b>B.E , MBA-(Power Management)</b>	<b>Certified Energy Auditor ( EA-10382)</b>	<b>15 yrs</b>
4	<b>Mr. Rahul Agrawal</b>	<b>BE electrical</b>	<b>Certified Energy Auditor (CEA- 20984)</b>	<b>11 yrs</b>
5	<b>Mr. Jayendra Mohabe</b>	<b>Diploma (Electrical)</b>	<b>Energy Engineer</b>	<b>11 yrs</b>
6	<b>Mr. Bhumesh Jagnit</b>	<b>Diploma (Electrical)</b>	<b>Energy Engineer</b>	<b>2 Yrs.</b>



# Annual Energy audit report of Cochin Port Authority (2021-22)

## 1. Executive Summary

M/s Cochin Port Authority is a deemed distribution licensee under the proviso to Section 14 of Electricity Act 2003. Commission has granted permission to CPT to extend its power distribution area to the Special Economic Zones at Vallarpadam and Puthuvypeen in Ernakulam District in Kerala State. The Distribution Business Unit of CPA performs the distribution of electricity across the entire W/Island area, Vallarpadam and Puthuvypin areas. CPT is having 2 power injection points, one at Willington Island area under 110KV system with contract demand of 6500 KVA and another is at Vallarpadam SEZ area under 11 KV with contract demand of 3000 KVA.

Under the KSERC, the distribution side metering is starting from the transformer primary side. Thus the transmission loss has to be borne by the consumer or the DISCOMs and not KSEB which is an govt electricity distribution agency. The Net Input Energy is always the sum of feeder wise data. Thus, there will always be a difference between the feeder data and the actual input energy due to the losses in the transformer and the cables up to the feeder area.

On the objective of green port CPA have installed 250 KW solar plant ( Roof top and ground mounted).

### 1.1 Energy accounts and performance of FY 2021-22

#### 1.1 Discom wide energy accounting

Table 2: Input Energy

Form-Input energy (Details of Input Energy & Infrastructure)		
Sr. No	Parameters	Value
1	Input Energy purchased (Million Unit (MU))	36.719
2	Transmission loss (%)	0.00%
3	Transmission loss (MU)	0
4	Energy sold outside the periphery (MU)	0
5	Open access sale (MU)	0
6	Net Billed energy in (MU)	35.405

The technical losses and aggregate technical & commercial (AT&C) losses for FY 2020-2021 are estimated and presented in the following table.

Table 3: T&D Losses

Losses	T&D Losses		AT & C loss (%)
	T&D loss (MU)	T&D loss (%)	
		1.313	3.577%

# Annual Energy audit report of Cochin Port Authority (2021-22)

The total sales (metered and assessed) for various consumer categories are presented in the following table:

Table 4: Category of Consumers

S.No.	Particulars	Number of consumers	Units Sold (MU)
			MU
A)	<b>Revenue from sale of electricity</b>		
	<b>LT Categories</b>		
1	LT I DOMESTIC	457	0.726262
2	LT II COLONY	2	0.30108
3	LT IV A (Industry) (RC3)	2	0.013605
4	LT VI A (RC4C)	14	0.242725
5	LT VI B	26	0.127236
6	LT VI B G	21	0.158469
7	LT VI C	7	0.243948
8	LT VI C G	12	0.064688
9	LT VI F	4	0.225765
10	LT VII A SINGLE PHASE	336	0.326404
11	LT VII A THREE PHASE	195	2.76316
12	LT VII C	1	0.000078
13	LT VIII B Street lights	3	0.009096
14	Self consumption	107	2.189078
15	STREET LIGHT- SELF	1	0.331021
	<b>HT Categories</b>		
1	HT I GOVT	6	1.359137
2	HT I INDUSTRY	1	0.483572
3	HT II (B) C GOVT	1	0.342558
4	HT IV COMMERCIAL	23	20.47041
5	HT IV B HOTEL	4	5.02753

The above table is done based on schedule of tariff and terms and conditions for retail supply of electricity by Kerala state electricity board limited document.

There are no agriculture consumers with in the distribution licensee area of supply.

Table 5: Details of Consumer Category (2021-22)

Sr No.	Type of consumer category	Details of consumer category for 2021-22	
		No. of consumers	%
1	Residential	459	38.2
2	Agricultural	0	0.0
3	Commercial/Industrial-LT	552	46.0
4	Commercial/Industrial-HT	28	2.3
5	Others	184	15.3
	Total	1223	100

# Annual Energy audit report of Cochin Port Authority (2021-22)

## 1.2 Status of metering infrastructure for energy accounting and auditing

Table 6: Status of metering Infrastructure for energy Accounting and Auditing

Pre-requisites for annual energy audit and periodic energy accounting	Identification and mapping of all of the electrical network assets	Through IPDS (Integrated Power Distribution Scheme) total area has been completed.
	Identification and mapping of high tension and low-tension consumers	All the HT and LT consumers have been mapped.
	Development and implementation of information technology enabled energy accounting and audit system, including associated software	In CoPA, AMI Software is used to fetch data from smart meters installed at customer premises and integrated with SAP.  Monthly Invoices are being generated from SAP by Finance Department. Various reports including preparation of energy audit and accounting reports are generated from SAP system.
Electricity distribution company ensures the installation of functional meters for all consumers, transformers and feeders. Meter installation is done in a phased manner within a period of three financial years from the date of the commencement of these regulations in accordance with the trajectory set out in the First Schedule	Providing Smart Metering / Pre paid metering infrastructure for Consumers in Urban area at CoPA under IPDS  Ministry of Power, Government of India notified "Integrated Power Development Scheme" (IPDS) on 3rd December 2014 for Strengthening of sub-transmission and distribution networks in the urban areas with 60% GoI Grant to all the utilities and DISCOMs .  Accordingly proposal was initiated for development of infrastructure works including consumer meters. Further Ministry has directed to replace consumer meter with Smart meters.  All the HT and LT consumers are installed with smart meter by 2020 and all the self consumption are installed with electronic meter by March 2023.  Date of Completion: 31.07.2020	

Annual Energy audit report of Cochin Port Authority  
(2021-22)

	<p>Electricity distribution company has a centralized energy accounting and audit cell comprising of— (i) a nodal officer, an energy manager and an information technology manager, having professional experience of not less than five years; and (ii) a financial manager having professional experience of not less than five years</p>	<p>The CoPA has energy audit department with the following staff 1.A nodal officer- Exe Engineer (Elec)- Mr. Ajayakumar RS 2.Designated energy manager-Asst Exe - Engineer (Elec)- Mrs. Jayalakshmi S 3.A qualified information technology manager- Sr.Dy.Director EDP- Mr.C.Vinod 4.A qualified financial manager- Sr.Accounts officer – Mrs. Surya Madhu</p>
<p>Reporting requirements for annual energy audit and periodic energy accounting</p>	<p>Electricity distribution company has a nodal officer, who is a full time employee of the electricity distribution company in the rank of the Chief Engineer or above, for the purpose of reporting of the annual energy audit and periodic energy accounting and communicate the same to the Bureau.</p>	<p>The CoPA is complying with this requirement</p>
	<p>Electricity distribution company ensures that the energy accounting data is generated from a metering system or till such time the metering system is not in place, by an agreed method of assumption as may be prescribed by the State Commission</p>	<p>In CoPA, AMI Software is used to fetch data from smart meters installed at customer premises and integrated with SAP. Monthly Invoices are being generated from SAP by Finance Department. Various reports including preparation of energy audit and accounting reports are generated from SAP system.  Self Consumption is metered through electronic meter partially and 100% metering is not place but CoPA intent to complete 100% which is completed by March 2023.</p>

**Annual Energy audit report of Cochin Port Authority  
(2021-22)**

	<p>Metering of distribution transformers at Different Voltage Distribution System is done on cluster meter installed by the electricity distribution company</p>	<p>CoPA intends to install metering of distribution transformers at Different Voltage Distribution System up to is done by following the approach of cluster metering under Revamped Distribution Sector Scheme (RDSS) of REC.</p>
	<p>The energy accounting and audit system and software is developed to create monthly, quarterly and yearly energy accounting reports.</p>	<p>In CoPA, AMI Software is used to fetch data from smart meters installed at customer premises and integrated with SAP. Monthly Invoices are being generated from SAP by Finance Department. Various reports including preparation of energy audit and accounting reports are generated from SAP system.</p>
	<p>Electricity distribution company has provided the details of the information technology system in place as specified in clause (f) of regulation 5 that ensures minimal manual intervention in creating the energy accounting reports and any manual intervention of any nature, in respect of the period specified therein, shall be clearly indicated in the periodic energy accounting report</p>	<p>In CoPA, AMI Software is used to fetch data from smart meters installed at customer premises and integrated with SAP. Monthly Invoices are being generated from SAP by Finance Department. Various reports including preparation of energy audit and accounting reports are generated from SAP system.</p>
	<p>Replacement of 11 KV Panel 11 KV supply from the Q9 substation is being distributed by the old HT Panel Oil Circuit Breakers (OCBs) which was installed about 40 years ago and completed the life period. Most of the units in the panel are damaged and not functional. Since over the period due to re-arrangement of 11KV distribution system through the Ernakulam wharf and Q10 area Substations, most of the switches have been kept off and not in use. However the cable feeders in the substation are still in operation for interconnecting and regulating 11KV supply from/to Q10 substation , E/W substation , New</p>	<p><b>Replacement of old/ damaged panels with new 11KV RMU&amp; LT panels at Q9 Substation and SITC of shore supply Points at Q8/Q9 Berth at Willingdon Island</b></p> <p><b>Supply , Installation , Testing &amp; commissioning of Electrical Infrastructure like 500 A MV Panel, one number 500 KVA transformer etc at North End Substation (done along with North End Admin Building (NAB) Distribution infrastructure revamping)</b></p> <p><b>Status of project: Under Progress</b></p>



Annual Energy audit report of Cochin Port Authority  
(2021-22)

	<p>Cruise terminal at E/W &amp; New Power house and LT power supply to Q9 berth and yard areas etc.</p> <p>Hence it is high time to replace this old 11 KV Panel with new RMUs and to carry out a rearrangement of HT Cables for an efficient Electrical Distribution System at Q8/ Q9 /Q10 area.</p> <p>Hence it was proposed to replace the old 11 KV Panel with RMUs with SF6 Circuit Breakers and LBS units.</p>	
	<p>The Mattanchery Halt (MH) substation was commissioned around 30 years ago in 1990s. The 11KV panel VCB Panel installed inside the substation feeds HT supply to A2 area, CIFT, Tropicana, Konkan storage , IMU, Walkway including back feeding to other HT consumers such as NTRO etc. and LT supply to the consumers in the nearby location through substations at Mattanchery Halt, Tropicana/walkway etc through the HT feeders from this panel. The power supply is received from 110 KV substation through 3 feeders, namely, Q9-I, MH2 and MH3 to this panel. At present the VCB Panels are in very damaged , dilapidated condition due to ageing and extensive use. The VCB units in the panels are not in operating condition and are by-passed and cables are temporarily connected for resuming the power supply . Hence it was proposed to replace the damaged panels with new SF6 RMUs panel for efficient switching, trouble free operation considering safety and reliability of the distribution systems. The survey reported copy of the HT panels are attached for perusal.</p>	<p><b>Replacement of old 11KV VCB Panels with new 11KV SF6 RMU panel at Mattancherry Halt Substation of Cochin Port Authority</b></p> <p><b>Status of the project: Under Progress</b></p>

## Annual Energy audit report of Cochin Port Authority (2021-22)

<p>Ministry of Power, Govt. of India has declared a financial support Scheme namely “Revamped Distribution sector Scheme (RDSS)” for the infrastructure and smart metering works for all the DISCOMs with the objective of improving the quality and reliability of power supply to the consumers and reducing AT&amp;C losses . Smart metering for all the consumers has been made mandatory by the Central Govt by b2026 and to be implemented in a phased manner.</p> <p>15 % of total cost for smart metering and 60 % of cost for infrastructure works will be received as grant from MoP based on result evaluation matrix and 40 % of the cost is to be borne by DISCOMs</p> <p>The following works have been identified and submitted to MoP by CoPA to be taken up under the above scheme and approval from Ministry of Power has been received. Technical specification of the works by Project Management Agency is being carried out.</p>	<b>Smart metering Works</b>	
	SITC of DT /Feeder Metering	35 DT meters & 4 feeder meters
	<b>Loss reduction works</b>	
	Replacement of old/low efficient transformers	20 Nos
	Replacement /Providing LT AB Cables	2.9 CKm
	Reconditioning /replacement of Old 11KV HT UG cables	1.5 Ckm
	Replacement of 3.3/0.433 KV transformers with 11KV/0.433 KV transformers	3 Nos
	Replacement of 3.3 KV Panel with 11 KV SF6 RMU	3 Nos
	<b>Modernization Works</b>	
	Supply, Laying , commissioning & Testing of New 11 KV AB Cables	5.9 Ckm
	Supply, Laying , commissioning & Testing of New 11 KV UG Cables	1.75 Ckm
	Replacement of old UG cables with new 11 KV AB Cables	6.5 Ckm
	Replacement of old UG cables with new 11 KV UG Cables	0.75 Ckm
	Supply, Laying , commissioning & Testing of new LT AB Cables	6.2 Ckm
	Replacement of damaged and obsolete Transformers	3 Nos
	Replacement of old Air break RMUs (3 Panel unit) with SF6 RMU with DA.	11 Nos
	SITC of New VCB feeder for bay extension	3 Nos
<b>SCADA –DMS</b>		
SITC of SCADA- DMS including 11KV RMUs with in built RTU/FRTU communication systems and accessories of DT Metering	31 sets	



# Annual Energy audit report of Cochin Port Authority (2021-22)

	Smart LED Street lighting is street lighting using high efficiency LED lamps with wireless control and monitoring systems which can be controlled and monitored automatically through IoT (Internet of Things). Through smart street lighting, the control and monitoring of the entire street light system can be done automatically without manual intervention.	<b>Implemented of Smart LED street Lighting in the direction of the visions of MIV 2030 by implementing innovative methods using latest technologies.</b>
--	--	---

## 1.3 Energy conservation measures already taken and proposed for future

The following are some of the energy conservation initiatives undertaken by the DISCOM:

- Replacement of existing Transformer with energy efficient transformer : The license has stated that they expect new consumers and strengthening of distribution network through replacement of old transformers with new energy efficient transformers is necessary to cater the power demand of such new consumers and provide better service to the existing consumers.
- Installation of Star rated equipment's like transformers, Air conditioners, fans etc. are being purchased and used in Cochin Port Authority.

## Annual Energy audit report of Cochin Port Authority (2021-22)

- Installation of LED lighting and BLDC fans: Conventional lamps in the office buildings have been replaced with LED lamps ,Only LED lamps are used in new street lights and high mast lights.

Table 7: ENCON Implementation for 21-22

Location	Description	Numbers	watts before replacement	watts after replacement	Saving in kWh per annum	implementation year
For sub roads/cross roads	150 W sodium vapour lamp replaced with 45 W LED	85	150	45	39091.5	May-21
Main roads	250 W sodium vapour lamp replaced with 70 W LED	150	250	70	132600	May-21
High Mast	400 W sodium flood light replaced with 200 W	17	400	200	16388	May-21
Office-1	40 W Fluorescent tube replaced with 20 W LED	1000	40	20	87600	Nov-20
Office-2	40 W Fluorescent tube replaced with 20 W LED	250	40	20	21900	Nov-21
Office-3	40 W Fluorescent tube replaced with 20 W LED	125	40	20	10950	Jan-22
Office-4	40 W Fluorescent tube replaced with 20 W LED	125	40	20	10950	May-22
Office-1	75 W conventional fans with 35 W BLDC fans	40	65	33	5606.4	Jan-22

# Annual Energy audit report of Cochin Port Authority (2021-22)

## 2. Summary of critical analysis of energy auditor and management analysis

### 2.1 Compliance to BEE regulations

The DISCOM has been submitting quarterly energy accounts as per BEE regulations however the DISCOM has not posted them on their website as per BEE regulations as the approval of report is pending from BEE and will be uploaded after the approval. The DISCOM also formed Energy Audit Cell as per the regulations. There is no agriculture consumers. There are four category of consumers residential, Commercial/Industrial LT & HT and Others. There is no transformer meters installed so the feeder wise loss cant be calculated. Both HT & LT Consumers are fully installed with smart meters but in self consumption areas of CoPA is not metered and objective is to install the smart meters by March 2022. Which will help in identify the exact losses.

Management Analysis: Going forward, the quarterly reports shall be uploaded unto the website of the DISCOM.

### 2.2 Feeder metering and energy audit

The DISCOM has 75% metering for all the 11 kV feeders (out of 15 nos feeder only 11 nos are metered), HT and LT consumers which has provided energy input and consumption/sale data of all consumers (1223 no.s). The total loss estimated through a mechanism/methodology to adjust for this difference so that the Input energy and sales/consumption data is more accurately reported for estimation of T&D Loss. The total T&D loss as per methodology is 1.313 MU. As per official say all the self consumption metered by March 2023.

Management Analysis: In CoPA, 100% Consumers are metering with communicable features work has been completed for all voltage level both HT and LT. The Input energy mentioned in the Annual report is for the Financial year FY-21-22 (April 2021 to March 2022), further for preparation of AAR for a particular month, input energy is considered for the previous month for Example: for FEB DCB, JAN input is considered (Since the consumption of energy in the meter for the month of JAN will be read from 1st of FEB onwards). the sales has been consider from May-21 to April -22.

### 2.3 Category wise subsidy

As per tariff policy, For Low Tension - I- Domestic ( LT- I ) : Fixed charges shall not be applicable to consumers belonging to below poverty line (BPL) category with connected load of and below 1000 watts and monthly consumption of and below 40 units.

BPL family having cancer patients or permanently disabled persons as family members due to polio or accidents, and consume upto 100 units per month shall be billed @Rs 1.50/unit, provided their connected load is of and below 1000 watts.

# Annual Energy audit report of Cochin Port Authority (2021-22)

The tariff for domestic consumption by the families of the victims of endosulfan tragedy in Hosdurg and Kasaragod Taluks of Kasaragod District shall be Rs.1.50 / unit for a monthly consumption up to 150 units. If the consumption of the consumer, who is eligible for the above concession, exceeds 150 units per month, the consumption in excess of 150 units will be charged at the rates specified for the slabs 151-200 units or 201-250 units as the case may be. This concession will not be available for the consumers with monthly consumption above 250 units.

So there is no actual subsidy from the government of kerala. There is subsidy through tariff as mentioned above.

## 2.4 Analysis on T&D Losses and AT&C Losses

Aggregate Technical & Commercial Loss (AT&C Loss) is defined as the summation of all technical as well as commercial power loss that occurs due to electrical power flow through sub-transmission and distribution network.

Technical Loss is defined as the summation of power loss through 11 kV line and LT line loss including transformer loss and others.

Commercial Loss is defined as the summation of power loss occurring due to theft/pilferage, deficient meter, inefficiency in billing & unrealized revenue due to collection inefficiency.

Computation of AT& C Loss:

Aggregate Technical & Commercial Loss (AT&C) is computed from the actual meter readings of the meter installed at various locations in the system.

Overall Billing Efficiency (%) = Total Sale in MU/ Total input in MU

Overall Collection Efficiency (%) = Total Collection Received (Rs. in Crs.) / Total Billing to Consumers (Rs. in Crs.)

AT & C Loss (%) = 1-{Collection Efficiency (%) x Billing Efficiency (%)}

**% Losses – Aggerate-** The overall Technical Loss (T&D Loss) is 3.43% and overall AT&C Loss is 3.577% for FY 2021-2022. This reflects an overall collection efficiency of 100% and loss is low compared to the other DISCOMS which is between (5 to 10%).

**% Losses – Voltage Wise-** DISCOM has electricity distribution of voltage levels 11 kV/415V and losses cant be assessed on 11 KV/415 KV due to no availability of meters on RMU. The losses of which is 3.577% and overall AT&C Loss is 3.577% for FY 2021-2022.

**Management Analysis:** Energy accounting at all voltage levels shall be carried out in due course and metering of the DTR's is in progress.

# Annual Energy audit report of Cochin Port Authority (2021-22)

## Collection Efficiency:

There is no division or circle in this CoPA, since total demand combining both Willington and Vallarpadam is 9500 MVA and total consumer is about 1199 nos. there is no need for the division or circle in CoPA. So the collection efficiency of the total year is tabled below:

Table 8: Collection efficiency of CoPA

S. No.	Source of Power (Station wise)	Total Annual Fixed charges (Rs.Lakhs)	Total Variable Charges (Rs.Lakhs)	Total Input Cost ( Rs Lakh)	Total Billed Amount ( Rs Lakh)	Total Collected Amount ( Rs Lakh)	Collection Efficiency %
1	21/1135 - Willington Island	222.37	1555.161	1,777.53	3589.54	3589.54	100
2	5/5403 - Vallarpadam	92.92	662.835	755.75			
	<b>Total</b>	315.29	2,218.00	2,533.28	3589.54		

From the above table, the total collection efficiency is 100%.

## 2.5 Circle wise % Losses:

Based on the voltage, There are three circles and losses are tabled below:

Table 9: Circle losses

S. No.	Voltage Level	No of Feeders	Feeders metered	Energy Input	Energy Sent to lower network	Direct Sale	Total Output	Total Losses	Total Losses (% of Energy Input)
1	110KV	11	11	25.494	0			0.159	3.577
2	11 KV	4	4	10.866	0	27.68	27.68	0.973	
3	LT			0.358		7.72	7.72	0.34	
...				36.719		35.405	35.405	1.313	

## 2.6 Category wise % Losses

M/s Cochin Port Authority (CoPT) has classified the various consumers category into mainly 5 types as specified in Sector Specific Pro-forma of Form-1. The categories are:

1. Residential
2. Agricultural
3. Commercial/Industrial LT
4. Commercial/Industrial HT
5. Others ( Government office, Non Profit organization, self consumption, and street lights)

There are no agriculture consumers with in the distribution licensee area of supply.

Submitted by Greenserve Energy Management solutions  Page | 19

Durg

# Annual Energy audit report of Cochin Port Authority (2021-22)

The consumption and number of consumers are tabled below:

Sr No.	Type of consumer category	Details of consumer category for 2021-22			
		No. of consumers	%	Consumption ( MU)	% of consumption
1	Residential	459	38.2	1.03	2.90
2	Agricultural	0	0.0	0	0.00
3	Commercial/Industrial-LT	552	46.0	3.55	10.00
4	Commercial/Industrial-HT	28	2.3	25.98	73.24
5	Others	184	15.3	4.845	13.87
	<b>Total</b>	<b>1223</b>	<b>100</b>	<b>35.405</b>	<b>100.00</b>

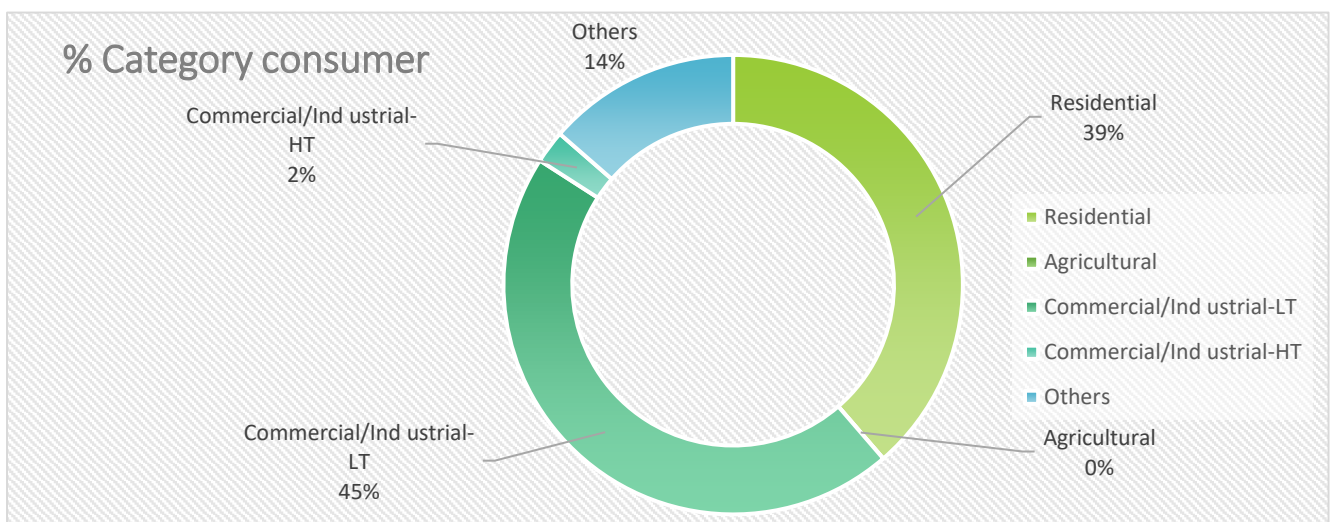

graph 1: % of Category of Consumer

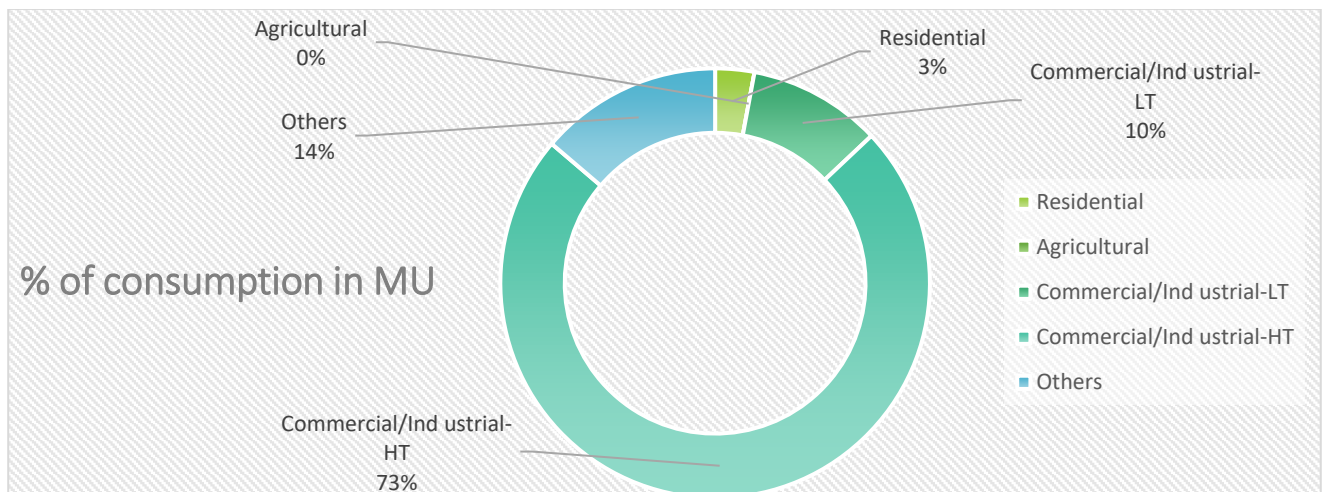

graph 2: % Consumption in MU

# Annual Energy audit report of Cochin Port Authority (2021-22)

## 3. Background

### 3.1 Extent regulations and role of bee

Bureau of Energy Efficiency (BEE) notified the Bureau of Energy Efficiency (Manner and Intervals for Conduct of Energy Audit (Accounting) in Electricity Distribution Companies) Regulations, 2021 on 6th October 2021. As per the regulation, all Electricity Distribution Companies are mandated to conduct annual energy audit and periodic energy accounting on quarterly basis.

Owing to the impact of energy auditing on the entire distribution and retail supply business and absence of an existing framework with dedicated focus on the same, it was imperative to develop a set of comprehensive guidelines that all Distribution utilities across India can follow and adhere to.

These Regulations for Energy audit in Electricity Distribution Companies provides broad framework for conduct of Annual Energy Audit though and Quarterly Periodic Energy Accounting with necessary Pre-requisites and reporting requirements to be met.

The extant regulations relevant or reproduced as under:

**Pre-requisites for annual energy audit and periodic energy accounting** — Save as otherwise provided, every electricity distribution company shall undertake all actions as may be required for the annual energy audit and periodic energy accounting before the start of the relevant financial year, including the following actions, namely: —

- (a) the identification and mapping of all of the electrical network assets;
- (b) the identification and mapping of high tension and low-tension consumers;
- (c) the development and implementation of information technology enabled energy accounting and audit system, including associated software;
- (d) the electricity distribution company shall ensure the installation of functional meters for all consumers, transformers and feeders:

Provided that meter installation may be done in a phased manner within a period of three financial years from the date of the commencement of these regulations in accordance with the trajectory setout in the First Schedule;

(e) all distribution transformers (other than high voltage distribution system upto 25kVA and other distribution system below 25 kVA) shall be metered with communicable meters. And existing noncommunicable distribution transformer meters shall be replaced with communicable meters and integrated with advanced metering infrastructure;

(f) the electricity distribution company shall establish an information technology enabled system to create energy accounting reports without any manual interference:

Provided that such system may be established—



# Annual Energy audit report of Cochin Port Authority (2021-22)

- (i) within a period of three years from the date of the commencement of these regulations in case of urban and priority area consumers; and
- (ii) within five years from the date of the commencement of these regulations in case of rural consumers;
- (g) the electricity distribution company shall create a centralized energy accounting and audit cell comprising of—
  - (i) a nodal officer, an energy manager and an information technology manager, having professional experience of not less than five years; and
  - (ii) a financial manager having professional experience of not less than five years;
- (h) any other requisite that Bureau may direct for energy audit and accounting purpose.

## **Reporting requirements for annual energy audit and periodic energy accounting-** (1)

Every electricity distribution company shall designate a nodal officer, who shall be a full time employee of the electricity distribution company in the rank of the Chief Engineer or above, for the purpose of reporting of the annual energy audit and periodic energy accounting and communicate the same to the Bureau.

(2) Every electricity distribution company shall ensure that the energy accounting data is generated from a metering system or till such time the metering system is not in place, by an agreed method of assumption as may be prescribed by the State Commission.

(3) Metering of distribution transformers at High Voltage Distribution System upto 25KVA can be done on cluster meter installed by each electricity distribution company.

(4) The energy accounting and audit system and software shall be developed to create monthly, quarterly and yearly energy accounting reports.

(5) Every electricity distribution company shall provide the details of the information technology system in place as specified in clause (f) of regulation 5 that ensures minimal manual intervention in creating the energy accounting reports and any manual intervention of any nature, in respect of the period specified therein, shall be clearly indicated in the periodic energy accounting report.

**Manner of annual energy audit and periodic energy accounting.** - (1) Every annual energy audit and periodic energy accounting under these regulations shall be conducted in the following manner, namely: —

- (a) verification of existing pattern of energy distribution across periphery of electricity distribution company; and
- (b) verification of accounted energy flow submitted by electricity distribution company at all applicable voltage levels of the distribution network,—
  - (i) energy flow between transmission and 66kV/33kV/11kV incoming distribution feeders;

# Annual Energy audit report of Cochin Port Authority (2021-22)

- (ii) energy flow between 66kV/33kV outgoing and 11kV/6.6kV incoming feeders;
  - (iii) energy flow between 11 kV/6.6kV feeders and distribution transformers, or high voltage distribution system;
  - (iv) energy flow between distribution transformer, or high voltage distribution system to end consumer, including ring main system;
  - (v) energy flow between Feeder to end-consumer; and
  - (vi) energy flow between 66/33/11 kV directly to consumer.
- (2) The accredited energy auditor, in consultation with the nodal officer of the electricity distribution company shall, —
- (a) develop a scope of work for the conduct of energy audit required under these regulations;
  - (b) agree on best practice procedures on accounting of energy distributed across the network; and
  - (c) collect data on energy received, and distributed, covered within the scope of energy audit.
- (3) The accredited energy auditor shall—
- (a) verify the accuracy of the data collected in consultation with the nodal officer of the electricity distribution companies as per standard practice to assess the validity of the data collected; and
  - (b) analyse and process the data with respect to—
    - (i) consistency of data monitoring compared to the collected data;
    - (ii) recommendations to facilitate energy accounting and improve energy efficiency; and
    - (iii) with respect to the purpose of energy accounting in reducing losses for the electricity distribution company.

**Prioritization and preparation of action plan.** - (1) The annual energy audit report submitted by accredited energy auditor in consultation with the nodal officer and periodic energy accounting report submitted by energy manager of the electricity distribution company shall include following activities, namely: —

- (I) data collection and verification of energy distribution—
  - (a) monthly energy consumption data of consumers and system metering from electricity distribution company at following voltage levels —
    - (i) 33/66/132 kV levels, including 33/66/132kV feeder and Sub-station;
    - (ii) 11/22 kV levels, including 11/22 kV feeder and Distribution Sub-station;
    - (iii) 440 V level, including Distribution Transformer and low-tension consumer;

# Annual Energy audit report of Cochin Port Authority (2021-22)

- (b) input energy details for all metered input points;
- (c) boundary meter details;
- (d) source of energy supply (e.g. electricity from grid or self-generation), including generation from renewables.
- (e) review of the current consumption practices in order to identify the energy loss in the system;
- (II) data verification, validation and correction—
  - (a) a monitoring and verification protocol to quantify on annual basis the impact of each measure with respect to energy conservation and cost reduction for reporting to Bureau and the concerned State designated agency;
  - (b) verification and correction of input energy, taking into account the following—
    - (i) recorded system meter reading by metering agency;
    - (ii) all the input points of transmission system;
    - (iii) details provided by the transmission unit;
    - (iv) relevant records at each electricity test division for each month;
    - (v) recorded meter reading at all export points (where energy sent outside the State is from the distribution system); and
    - (vi) system loading and corresponding infrastructure;
  - (c) energy supplied to Open Access Consumers which is directly purchased by Open Access Consumers from any supplier other than electricity distribution company; and
  - (d) verify and validate the system metering data provided by metering agency through random field visit (particularly for data irregularity).”

## 3.2 Purpose of audit and accounting report

Energy Accounting means accounting of all energy inflows at various voltage levels in the distribution periphery of the network, including renewable energy generation and open access consumers, and energy consumption by the end consumers. Energy accounting and a consequent annual energy audit would help to identify areas of high loss and pilferage, and thereafter focus efforts to take corrective action.

## 3.3 Period of energy auditing and accounting

The present Annual Energy Audit and accounting is for the period FY 2021-2022 and is the first Annual Energy Audit under BEE regulations 2021

# Annual Energy audit report of Cochin Port Authority (2021-22)

## 4. Project Introduction

### 4.1 Name and address of DISCOM

#### **Cochin Port Authority**

Willingdon Island, Kochi,

Kerala 682009

### 4.2 Name and details of energy manager and authorized signatory of DISCOM

Table 10: Details of Authorized Authority

<b>Details of Energy Auditor</b>	<b>Details of Authorized Signatory</b>
Mrs. Jayalakshmy.S Asst. Exe. Engineer(El)- EM Cochin Port Authority Willingdon Island,Kochi, Kerala 682009 Phone No: 9496450704	Mr. R.S Ajayakumar Executive Engineer Cochin Port Authority Willingdon Island, Kochi, Kerala 682009 Phone No: 9444610664

### 4.3 Summary profile of DISCOM

#### 4.3.1 Asset Details

Table 11: Asset Details

Sr. No.	Particulars	Value in FY 2021-2022
1	No of Sub station ( 110 KV to 11 KV)	11
3	Length of 11 KV line (Ckt KM)	84
4	Length of Low-tension line ( Ckt KM)	252
5	Number of Distribution Transformers	46
6	Number of circles	1
7	Number of divisions	0
8	Number of Feeders	15
9	Number of RMU	73

The Asset details includes the no of transformers, substations and feeders which are tabled above.

# Annual Energy audit report of Cochin Port Authority (2021-22)

## 4.3.2 Energy flow

Table 12: Energy Flow

Sr. No.	Energy Flow Details	Unit	Value
1	Input Energy Purchase (From Feeding at main substation)	Million Unit	36.719
2	Net input energy (at DISCOM Periphery after adjusting the transmission losses and energy traded)	Million Unit	36.719
3	Total Energy billed (is the Net energy billed, adjusted for energy traded))	Million Unit	35.405
4	Transmission and Distribution (T&D) loss Details	Million Unit	1.313
		%	3.577%
5	Collection Efficiency	%	100%
6	Aggregate Technical & Commercial Loss	%	3.577%

## 4.3.3 Consumer base

Table 13: Consumer base

Sr. No.	Parameters	66kV and above	33kV	11/22kV	LT
1	Number of conventional metered consumers	0	0	0	0
2	Number of consumers with 'smart' meters	0	0	35	1188
3	Number of consumers with 'smart prepaid' meters	0	0	0	0
4	Number of consumers with 'AMR' meters	0	0	0	0
5	Number of consumers with 'non-smart prepaid' meters	0	0	0	0
6	Number of unmetered consumers	0	0	0	0
	<b>Number of total consumers</b>	<b>0</b>	<b>0</b>	<b>35</b>	<b>1188</b>

# Annual Energy audit report of Cochin Port Authority (2021-22)

## 4.3.4 Power supply position

Table 14: Power supply to consumers

Sr. No.	Particulars	Unit	Value in FY 2021-2022
1	Peak demand of a day	Mega Watts	NA
2	Maximum consumption of a day	Million Units	NA
3	Annual Energy Input during the year	Million Units	36.719
4	Metered sales during the year	Million Units	35.405
5	Agriculture consumption during the year	Million Units	0
6	Energy losses during the year (Incl. EHT Sales)	Million Units	1.313

## 4.3.5 Power Purchase

The licensee revised the power purchase for the control period subsequently. As per revised form D3.1 (Power Purchase Expenses) the licensee has shown the details of the proposed power purchase cost for the control period, which includes the cost for power purchase from KSEB Ltd and own Solar Generation.

The power purchase cost claimed by the licensee for the year 2021-22 amounts to Rs.2533.3 lakh for a purchase of 363.61 lakh units. This amount included power purchase from KSEB Ltd, Own generation (Solar) and Open access power. Compared to 2019-20 (Rs.6.96/per unit) average power purchase cost has increased in the year 2021-22 (Rs.6.97/per unit).

Table 15: Power Purchase details

Particulars	2021-22		
	W/Island	Vallarpadam	Total
Energy purchase (In lakh units)	254.945	108.662	363.61
Demand Charges (Rs. /KVA)	340	340	340
Total Demand charges (Rs in lakh) (A)	222.37	92.9152	315.29
Energy Charges (Rs. /KWh)	6.1	6.1	6.1
Total energy Charges (Rs.in lakhs) (B)	1555.16	662.835	2218
Cost of power purchase (A) +(B) (Rs.in lakh)	1777.53	755.75	2533.3
Average Power Purchase Cost (Rs. / per unit)			6.97

# Annual Energy audit report of Cochin Port Authority (2021-22)

## 4.4 Key Projects

Several initiatives have been taken up to strengthen and stabilise the distribution system and the innovative initiatives are as follows:

### **Providing shore power supply facilities for cruise vessels calling at cochin port :**

To establish shore supply facilities at Q8&Q9 berths of E/Wharf at the cruise terminal frontage of Cochin Port. The terminal at E/Wharf, it was expected berthing of about 60Nos. cruise vessels at Kochi annually. When new International cruise terminal is commissioned, the number of vessels is expected to increase from 60 to 70 within a year. To reduce the pollution level to some extent it is right time to establish shore power facility at Q8 & Q9 berths.

The Cold Ironing Facility needs to comply with IEC/ISO/IEEE 80005 international standard (Utility Connections in Port: High Voltage Shore Connection (HVSC) systems).

- A. 2 sets of shore power systems with a maximum power at 4MVAX2 with 60 HZ and voltage rating of 6.6KV and 11KV.
- B. 2 sets of shore power systems with a maximum power at 4MVAX2 with 50 HZ and voltage rating of 11KV.

### **Replacement of old/ damaged panels with new 11KV RMU& LT panels at Q9 Substation and SITC of shore supply Points at Q8/Q9 Berth at Willingdon Island**

11 KV supply from the Q9 substation is being distributed by the old HT Panel Oil Circuit Breakers (OCBs) which was installed about 40 years ago and completed the life period. Most of the units in the panel are damaged and not functional. Since over the period due to re- arrangement of 11KV distribution system through the Ernakulam wharf and Q10 area Substations, most of the switches have been kept off and not in use. However the cable feeders in the substation are still in operation for interconnecting and regulating 11KV supply from/to Q10 substation , E/W substation , New Cruise terminal at E/W & New Power house and LT power supply to Q9 berth and yard areas etc.

Hence it is high time to replace this old 11 KV Panel with new RMUs and to carry out a rearrangement of HT Cables for an efficient Electrical Distribution System at Q8/ Q9 /Q10 area.

Hence it was proposed to replace the old 11 KV Panel with RMUs with SF6 Circuit Breakers and LBS units.

**Supply , Installation , Testing & commissioning of Electrical Infrastructure like 500 A MV Panel, one number 500 KVA transformer etc at North End Substation (done along with North End Admin Building (NAB) Distribution infrastructure revamping).**



# Annual Energy audit report of Cochin Port Authority (2021-22)

## **Replacement of old 11KV VCB Panels with new 11KV SF6 RMU panel at Mattancherry Halt Substation of Cochin Port Authority.**

The Mattancherry Halt (MH) substation was commissioned around 30 years ago in 1990s. The 11KV panel VCB Panel installed inside the substation feeds HT supply to A2 area, CIFT, Tropicana, Konkan storage , IMU, Walkway including back feeding to other HT consumers such as NTRO etc. and LT supply to the consumers in the nearby location through substations at Mattancherry Halt, Tropicana/walkway etc through the HT feeders from this panel. The power supply is received from 110 KV substation through 3 feeders, namely, Q9-I, MH2 and MH3 to this panel. At present the VCB Panels are in very damaged , dilapidated condition due to ageing and extensive use. The VCB units in the panels are not in operating condition and are by-passed and cables are temporarily connected for resuming the power supply . Hence it was proposed to replace the damaged panels with new SF6 RMUs panel for efficient switching, trouble free operation considering safety and reliability of the distribution systems. The survey reported copy of the HT panels are attached for perusal.

# Annual Energy audit report of Cochin Port Authority (2021-22)

## 5. Discussion and analysis

### 5.1 Energy accounts for previous years

The DISCOM is audited for the first time under BEE Regulations 2021. Hence there is no audit conducted for previous year

### 5.2 Energy accounts and performance

The net energy input to the DISCOM for FY 2021-2022 is estimated and presented in the following table.

Table 16: Performance Discom

Form-Input energy (Details of Input Energy & Infrastructure)		
Sr. No	Parameters	Value
1	Input Energy purchased (Million Unit (MU))	36.719
2	Transmission loss (%)	0.00%
3	Transmission loss (MU)	0
4	Energy sold outside the periphery (MU)	0
5	Open access sale (MU)	0
6	Net Billed energy in (MU)	35.405

As said earlier, the input energy for Willington Island is supplied from Kattari bag 110 KV substation of KSEB 4 km away from the CoPA substation of 110 KV. But the meter is installed in the substation, so the transmission loss is not accountable with CoPA.

F For Vallarpadam, the input energy is supplied 11KV from marine drive of Ernakulam through 2 nos of 11 KV feeder.

There are two types of Transmission and Distribution Losses

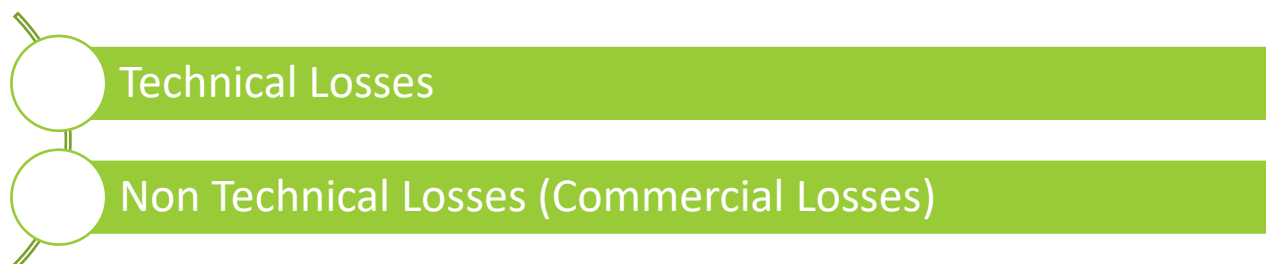

Technical Losses:

The technical losses are due to energy dissipated in the conductors, equipment used for transmission Line, Transformer, sub- transmission Line and distribution Line and magnetic losses in transformers.

# Annual Energy audit report of Cochin Port Authority (2021-22)

Generally Technical losses are normally 22.5%, and directly depend on the network characteristics and the mode of operation.

The major amount of losses in a power system is in primary and secondary distribution lines. While transmission and sub-transmission lines account for only about 30% of the total losses. Therefore the primary and secondary distribution systems must be properly planned to ensure within limits.

The unexpected load increase was reflected in the increase of technical losses above the normal level

Losses are inherent to the distribution of electricity and cannot be eliminated.

There are two Type of Technical Losses.

(a) Permanent / Fixed Technical losses:

- Fixed losses do not vary according to current. These losses take the form of heat and noise and occur as long as a transformer is energized.
- Between 1/4 and 1/3 of technical losses on distribution networks are fixed losses. Fixed losses on a network can be influenced in the ways set out below.
- Corona Losses.
- Leakage Current Losses.
- Dielectric Losses.
- Open-circuit Losses.
- Losses caused by continuous load of measuring elements
- Losses caused by continuous load of control elements.

(b) Variable Technical losses

- Variable losses vary with the amount of electricity distributed and are, more precisely, proportional to the square of the current. Consequently, a 1% increase in current leads to an increase in losses of more than 1%.
- Between 2/3 and 3/4 of technical (or physical) losses on distribution networks are variable Losses.
- By increasing the cross sectional area of lines and cables for a given load, losses will fall. This leads to a direct trade-off between cost of losses and cost of capital expenditure. It has been suggested that optimal average utilization rate on a distribution network that considers the cost of losses in its design could be as low as 30 per cent.
- joule losses in lines in each voltage level
- impedance losses
- Losses caused by contact resistance.

# Annual Energy audit report of Cochin Port Authority (2021-22)

## Common Reasons for Technical Losses:

- Lengthy Distribution lines
- Inadequate Size of Conductors of Distribution lines
- Installation of Distribution transformers away from load centers
- Low Power Factor of Primary and secondary distribution system
- Feeder Phase Current and Load Balancing
- Load Factor Effect on Losses
- Transformer Sizing and Selection
- Balancing 3 phase loads
- Switching off transformers
- Other Reasons for Technical Losses
  1. Unequal load distribution among three phases in L.T system causing high neutral currents.
  2. leaking and loss of power
  3. Over loading of lines.
  4. Abnormal operating conditions at which power and distribution transformers are operated
  5. Low voltages at consumer terminals causing higher drawl of currents by inductive loads.
  6. Poor quality of equipment used in cooler air-conditioners and industrial loads in urban areas.

## Non-Technical (Commercial Losses):

Non-technical losses are related to meter reading, defective meter and error in meter reading, billing of customer energy consumption, lack of administration, financial constraints, and estimating unmetered supply of energy as well as energy thefts.

## How Reduce Technical Losses:

- Converting LV Line to HV Line
- Large Commercial / Industrial Consumer get direct Line from Feeder
- Adopting Arial Bundle Conductor (ABC)
- Reduce Number of Transformer
- Utilize Feeder on its Average Capacity
- Replacements of Old Conductor/Cables
- Strictly Follow Preventive Maintenance Program

## Annual Energy audit report of Cochin Port Authority (2021-22)

The technical losses and aggregate technical & commercial (AT&C) losses for FY 2020-2021 are estimated and presented in the following table.

Table 17: AT&C Losses

Losses	T&D Losses		AT & C loss (%)
	T&D loss (MU)	T&D loss (%)	
		1.313	3.577%

The total sales (metered and assessed) for various consumer categories are presented in the following table.

Table 18: Category wise sales

S.No.	Particulars	Number of consumers	Units Sold (MU)
			MU
A)	<b>Revenue from sale of electricity</b>		
	<b>LT Categories</b>		
1	LT I DOMESTIC	457	0.726262
2	LT II COLONY	2	0.30108
3	LT IV A (Industry) (RC3)	2	0.013605
4	LT VI A (RC4C)	14	0.242725
5	LT VI B	26	0.127236
6	LT VI B G	21	0.158469
7	LT VI C	7	0.243948
8	LT VI C G	12	0.064688
9	LT VI F	4	0.225765
10	LT VII A SINGLE PHASE	336	0.326404
11	LT VII A THREE PHASE	195	2.76316
12	LT VII C	1	0.000078
13	LT VIII B Street lights	3	0.009096
14	Self consumption	107	2.189078
15	STREET LIGHT- SELF	1	0.331021
	<b>HT Categories</b>		
1	HT I GOVT	6	1.359137
2	HT I INDUSTY	1	0.483572
3	HT II (B) C GOVT	1	0.342558
4	HT IV COMMERCIAL	23	20.47041
5	HT IV B HOTEL	4	5.02753

# Annual Energy audit report of Cochin Port Authority (2021-22)

## 5.3 Critical analysis by energy auditor

### 5.3.1 compliance to bee regulations

The compliance status of DISCOM to various provisions of BEE Regulations 2021 is analysed and presented below.

*Table 19: Critical analysis by energy auditor*

Clause No	Clause Details	Sub Clause Number	Subclause Details	Present Status
3	Intervals of Time for conduct of annual energy audit	a	Conducted an annual energy audit for every financial year and submitted the annual energy audit report to the Bureau and respective State Designated Agency and also made available on the website of the electricity distribution company within a period of four months from the expiry of the relevant financial year	Annual energy audit for FY 2021-2022 being conducted. Report will be submitted to BEE and SDA.
4	Intervals of Time for conduct of periodic energy accounting.	a	All feeder wise, circle wise and division wise periodic energy accounting is conducted by the energy manager of the electricity distribution company for each quarter of the financial year.	Periodic energy accounting for Q1 FY22-23 been prepared by the CoPA.
		B	Submitted the periodic energy accounting report to the Bureau and respective State Designated Agency and also made available on the website of electricity distribution company within forty-five days from the date of the periodic energy accounting.	Periodic energy accounting for FY21-22 is prepared and submitted to BEE waiting got approval to published in website and Periodic energy accounting for Q1 FY22-21 have been prepared by the CoPA.
		C	Electricity distribution company conducted its first periodic energy accounting, for the last quarter of the financial year immediately preceding the date of such commencement.	CoPA has submitted its first periodic energy accounting for Q4 FY21-22.
		D	Electricity distribution company conducted its subsequent periodic energy accounting for each quarter of the financial year for a period of two financial years from the date of	The CoPA is submitting the periodic energy auditing

Annual Energy audit report of Cochin Port Authority  
(2021-22)

Clause No	Clause Details	Sub Clause Number	Subclause Details	Present Status
			such commencement, and submit the periodic energy accounting report within sixty days from the date of periodic energy accounting.	reports as per the Energy Audit regulations in due course.
5	Pre-requisites for annual energy audit and periodic energy accounting	A	Identification and mapping of all of the electrical network assets	Through IPDS all the networks are mapped through installing smart meters.
		B	Identification and mapping of high tension and low-tension consumers	All the HT and LT consumers have been mapped.
		C	Development and implementation of information technology enabled energy accounting and audit system, including associated software	In CoPA, AMI Software is used to fetch data from smart meters installed at customer premises and integrated with SAP. Monthly Invoices are being generated from SAP by Finance Department. Various reports including preparation of energy audit and accounting reports are generated from SAP system.
		D	Electricity distribution company ensures the installation of functional meters for all consumers, transformers and feeders. Meter installation is done in a phased manner within a period of three financial years from the date of the commencement of these regulations in accordance with the trajectory set out in the First Schedule	All consumers have been metered and 11 nos of feeders are meters and completed by 31.07.2020.  46 nos of Distribution transformers and 4 nos feeders need to be metered.
			d.1. 100% Communicable Feeder Metering integrated with AMI, by 31st December 2022 along with replacement of existing non-communicable feeder meters.	d.1. 100% of LT & HT consumers are metered with smart meters.  d.2. 46 nos of Distribution transformers targeted to be metered by 2022-23.



Annual Energy audit report of Cochin Port Authority  
(2021-22)

Clause No	Clause Details	Sub Clause Number	Subclause Details	Present Status
			<p>d.2. All <b>Distribution Transformers</b> (other than HVDS DT up to 25kVA and other DTs below 25 kVA) shall be metered with communicable meters. Communicable DT Metering for the following areas/ consumers to be completed by December 2023 and in balance areas by December 2025:</p> <p>d.2.1. All Electricity Divisions of 500 AMRUT cities, with AT&amp;C Losses &gt; 15%</p> <p>d.2.2. All Union Territories (for areas with technical difficulty, non-communicable meters may be installed)</p> <p>d.2.3. All Industrial and Commercial consumers</p> <p>d.2.4. All Government offices at Block level and above Other high loss areas i.e. rural areas with losses more than 25% and urban areas with losses more than 15%</p>	<p>d.2.1. All the consumers are metered already and completed by 2021.</p> <p>d.2.2. Not Relevant for CoPA.</p> <p>d.2.3. All the industrial and commercial (HT and LT) consumers are installed with smart meter.</p> <p>d.2.4 Government offices and others consumers are covered with smart meter.</p>
			<p>d.3. <b>Prepaid Smart Consumer Metering</b> to be completed for all directly connected meters and AMR in case of other meters, by December 2023 in the following areas:</p> <p>d.3.1. All Electricity Divisions of 500 AMRUT cities, with AT&amp;C Losses &gt; 15%;</p> <p>d.3.2. All Union Territories (for areas with technical difficulty, prepaid meters to be installed);</p> <p>d.3.3. All Industrial and Commercial consumers;</p> <p>d.3.4. All Government offices at Block level and above; Other high loss areas i.e. rural areas with losses more than 25% and</p>	<p>d.3.1. Not applicable as AT&amp;C loss is less than 15%.</p> <p>d.3.2. Not Relevant for CoPA.</p> <p>d.3.3. All the industrial and commercial (HT and LT) consumers are installed with smart meter under IPDS</p> <p>d.3.4. Government offices and others consumers are covered with smart meter.</p>

Annual Energy audit report of Cochin Port Authority  
(2021-22)

Clause No	Clause Details	Sub Clause Number	Subclause Details	Present Status
			urban areas with losses more than 15%.	
			d.4. Consumer Metering: 98% by FY 2022-23 99% by FY 2023-24	All domestic, residential, commercial and industrial are covered with smart meter of 100%.
			d.5. Targets for functional meters—Meter FY 22-23 FY 23-24 FY24-25 Feeder metering 98.5% 99.5% 99.5% DT metering 90% 95% 98% Consumer metering 93% 96% 98	Feeder Metering and DT metering are targeted to complete under 2022-23 under RDSS scheme.
		E	e.1. All distribution transformers (other than high voltage distribution system up to 25kVA and other distribution system below 25 kVA) is metered with communicable meters. e.2. And existing non communicable distribution transformer meters is replaced with communicable meters and integrated with advanced metering infrastructure.	e.1. CoPA intends to install communicable meters with AMI for <b>all distribution transformers</b> (other than high voltage distribution system up to 25kVA and other distribution system below 25 kVA) under Revamped Distribution Sector Scheme (RDSS) of REC.  CoPA intends to install communicable meters with AMI for existing non communicable distribution transformer meters under Revamped Distribution Sector Scheme (RDSS) of REC.
		F	Electricity distribution company has established an information technology enabled system to create energy accounting reports without any manual interference and such systems may be within a period of three years from the date of the commencement of these regulations in case of urban and priority area consumers; and within five years from the date of the commencement of these	In CoPA, AMI Software is used to fetch data from smart meters installed at customer premises and integrated with SAP.  Monthly Invoices are being generated from SAP by Finance Department. Various reports including preparation of energy audit and accounting reports are generated from SAP system.

Annual Energy audit report of Cochin Port Authority  
(2021-22)

Clause No	Clause Details	Sub Clause Number	Subclause Details	Present Status
			regulations in case of rural consumers	
		G	Electricity distribution company has a centralized energy accounting and audit cell comprising of— (i) a nodal officer, an energy manager and an information technology manager, having professional experience of not less than five years; and (ii) a financial manager having professional experience of not less than five years	The DC has energy audit department with the following staff 1.A nodal officer- Exe Engineer (Elec)- Mr. Ajayakumar RS 2.Designated energy manager- Asst Exe -Engineer (Elec)- Mrs. Jayalakshmi S 3. A qualified information technology manager- Sr.Dy.Director EDP- Mr.C.Vinod 4..A qualified financial manager- Sr.Accounts officer – Mrs. Surya Madhu
6	Reporting requirements for annual energy audit and periodic energy accounting	A	Electricity distribution company has a nodal officer, who is a full time employee of the electricity distribution company in the rank of the Chief Engineer or above, for the purpose of reporting of the annual energy audit and periodic energy accounting and communicate the same to the Bureau.	The CoPA is complying with this requirement
		B	Electricity distribution company ensures that the energy accounting data is generated from a metering system or till such time the metering system is not in place, by an agreed method of assumption as may be prescribed by the State Commission	In CoPA, AMI Software is used to fetch data from smart meters installed at customer premises and integrated with SAP.  Monthly Invoices are being generated from SAP by Finance Department. Various reports including preparation of energy audit and accounting reports are generated from SAP system.

Annual Energy audit report of Cochin Port Authority  
(2021-22)

Clause No	Clause Details	Sub Clause Number	Subclause Details	Present Status
		C	Metering of distribution transformers at High Voltage Distribution System up to 25KVA is done on cluster meter installed by the electricity distribution company	CoPA intends to install metering of distribution transformers at High Voltage Distribution System up to 25KVA is done by following the approach of cluster metering under Revamped Distribution Sector Scheme (RDSS) of REC.
		D	The energy accounting and audit system and software is developed to create monthly, quarterly and yearly energy accounting reports.	In CoPA, AMI Software is used to fetch data from smart meters installed at customer premises and integrated with SAP.  Monthly Invoices are being generated from SAP by Finance Department. Various reports including preparation of energy audit and accounting reports are generated from SAP system.
		E	Electricity distribution company has provided the details of the information technology system in place as specified in clause (f) of regulation 5 that ensures minimal manual intervention in creating the energy accounting reports and any manual intervention of any nature, in respect of the period specified therein, shall be clearly indicated in the periodic energy accounting report	In CoPA, AMI Software is used to fetch data from smart meters installed at customer premises and integrated with SAP.  Monthly Invoices are being generated from SAP by Finance Department. Various reports including preparation of energy audit and accounting reports are generated from SAP system.

#### 5.4 Inclusion and exclusions

1. The power from the solar power plant at power and Diesel generator are added with total input.
2. The self consumption includes the supply to CoPA admiration office, Guest house and other premises. With manual billing also included in the self consumption.

Annual Energy audit report of Cochin Port Authority  
(2021-22)

## 6. Notes of the EA/EM along with queries and replies to Data gaps

Query by EA, response by EM and Notes by EA is given below.

Table 20: Data Gap

Sr.No	Query by EA	Response by EM of DISCOM	Notes by EA
1	<p>What is source of data provided for self-consumption of CoPA and breakup of the self-consumption?</p> <p>Is the self consumption areas are metered?</p>	<p>Self consumption readings are taken from the individual meter installed in the individual premises. which are not smart meters and in some sections no meter is installed. Where some assumption are made for calculation.</p> <p>During 2021-22, 100% of the self consumption is metered.</p>	<p>Data for 2021-22 is consider through SAP and from electrical department.</p> <p>Nearly 75% of self consumption premises are installed with electronic meters and the remaining premises will be completed during 2023.</p>
2	<p>How solar generation are consider?</p> <p>Is it added with Input energy?</p>	<p>250 KW is installed and commissioned by 2019. and synchronized with grid and metered so the data is available.</p> <p>Yes its added with input energy and DG usage also added with input energy.</p>	<p>Data for 2021-22 is consider through electrical department.</p>

## 7. Recommendation

For energy conservative measures recommendation, the analysis have covered following areas

1. Replacement of conventional appliances with energy efficiency appliances
2. Strengthening the distribution system
3. Computation of Technical loss

Replacement of conventional appliances with energy efficiency appliances

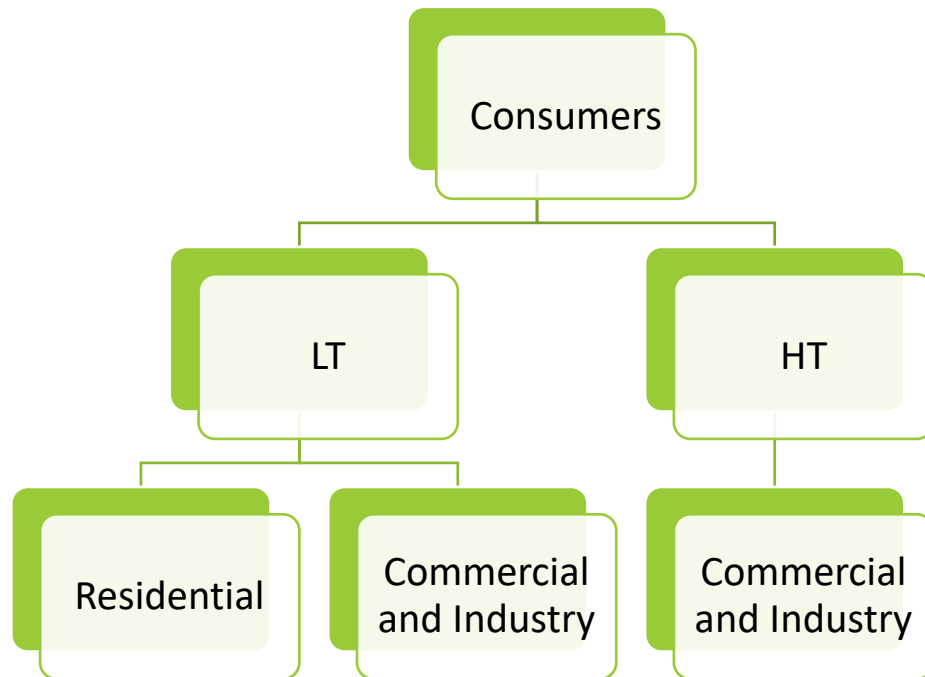

As represented above, in LT category there are 2 type of users one is residential where the major type of loads are Lighting, ceiling fan, Fridge , washing machine, heaters and Air conditioner. With standard & labelling program and advancement in the technology help reduce the energy by replacing conventional equipment's with star rated.

Though CoPA have started replacing equipment's in the self consumption premises from conventional lights to LED, ceiling fan to BLDC fan, electrical heaters to solar water heaters and replacing conventional AC to star rating AC.

There should be awareness campaign regarding energy efficiency which need to initiate from CoPA by various ways through printing saving of implementing replacing the star rated appliances , providing LED to consumers on the discounted rate, road campaign for creating awareness about importance of the energy efficiency.

All this programs can help in awareness of energy efficiency for residential consumers and same way for commercial and industrial LT consumers the major load will be heaters, Lighting, fans and others.

# Annual Energy audit report of Cochin Port Authority (2021-22)

In same way for HT consumers who consumes 75% of the total sales from the CoPA, so implementing the energy efficiency projects are must in the HT consumers. The major load in the HT consumers will be motors, chillers, AHU and Induction heaters. The voltage step down to 11 KV to 415 V through transformers so there will be load and no load losses. So the opportunity for the energy conservation is replacing of existing conventional transformer with star rated transformer.

## Strengthening the distribution system

CoPA have taken lot of initiatives to strengthen their distribution system. which are mentioned already above. Beyond their initiatives like installing smart meters for Feeders, distribution transformers, replacing some of under ground cables with overhead lines, installation of SCADA. this will help in reduce and monitor the losses.

These are some of the recommendation from our end to strength the distribution system:

- Converting old LV (430V) feeders to higher voltage the Investment Cost is high and often not economically justifiable but If parts of the LV (430V) Primary feeders are in relatively good condition, installing multiple step-down power transformers at the periphery of the 430 volt area will reduce copper losses by injecting load current at more points.
- Design the distribution network system in such a way that if it is Possible than large consumer gets direct Power Line from feeder.
- Where LT Line are not totally avoidable use Arial Bundle Conductor to minimize faults in Lines, to avoid direct theft from Line.
- Re conducting of Transmission and Distribution Line according to Load.
- Identification of the weakest areas in the distribution system and strengthening /improving them.
- Reducing the length of LT lines by relocation of distribution sub stations or installations of additional new distribution transformers.
- Installation of lower capacity distribution transformers at each consumer premises instead of cluster formation and substitution of distribution transformers with those having lower no load losses such as amorphous core transformers.
- Installation of shunt capacitors for improvement of power factor.
- Installation of single-phase transformers to feed domestic and nondomestic load in rural areas.
- Providing of small 25kVA distribution transformers with a distribution box attached to its body, having provision for installation of meters, MCCB and capacitor.
- Required to adopt Preventive Maintenance Program of Line to reduce Losses due to Faulty / Leakage Line Parts.
- Required to tights of Joints, Wire to reduce leakage current.



# Annual Energy audit report of Cochin Port Authority (2021-22)

## Computation of Technical loss

Technical loss is calculated based on the following formula:

Technical Loss is defined as the summation of power loss through 11 kV line and LT line loss including transformer loss and others

**% Losses – Aggerate-** The overall Technical Loss (T&D Loss) is 3.41% and overall AT&C Loss is 3.577% for FY 2021-2022. This reflects an overall collection efficiency of 100% and loss is low compared to the other DISCOMS which is between (5 to 10%).

Technical loss 4 types include:

1. Transmission Line Losses
2. Power Transformer Losses
3. Distribution Line Losses
4. Low-voltage Transformer and Distribution Line Losses

Typical line losses at each stage below the transmission receipt point. Transmission system line losses generally involve two (or more) additional transformation stages and one (or more) additional set of lines.

Table 21: Losses at Each Stage of Electricity Distribution

Losses at Each Stage of Electricity Distribution	
Component	Estimated Loss as a Percentage of Energy Sold
Sub transmission Lines	0.1
Power Transformers	0.1
Distribution Lines	0.9
Distribution Transformers No Load	1.2
Distribution Transformers Load	0.8
Secondary Lines	0.5
Total	3.6

### Reducing Transformer Losses

Recall that transformer losses are caused in two different ways, core (no-load) losses and resistive (copper) losses. Core losses are the losses incurred to energize the transformer. These vary with the size of the transformer and the materials used to construct the transformer. It is essential to “right-size” transformers to minimize core losses.

Resistive losses are primarily a function of the current flowing through a transformer, heating it up. These losses are exponential with the current. For this reason it is important to not have too small a transformer, or it will “run hot” with high losses. One option is for utilities to install banks of three or more transformers at substations, de-energizing one or more during low-load periods (to avoid excessive core losses), but then switching them on during high-demand periods (to avoid excessive resistive losses). Again, there

# Annual Energy audit report of Cochin Port Authority (2021-22)

may be trade-offs resulting from increased circuit breaker maintenance costs and risk for decreased reliability.

## **Reducing Line (Conductor) Losses**

All utility-grade conductors are made of very pure aluminum or copper, both of which have inherently low resistance to electrical current. There are three factors that contribute most significantly to conductor losses. The first is the quality of the connections at each end of the conductors (and any splices that may exist mid-line). The second is the size of the conductor relative to the amperage it carries. The third is the voltage at which the conductors operate.

Conductor size affects the resistance of the line to current passing through it. Where high amperage is anticipated, larger conductors are required, just as a larger-gauge extension cord is needed to handle power tools and other high-usage appliances. Utilities sometimes change out the wires or “re-conductor” an existing distribution circuit (without changing its voltage) in order to increase the capacity and reduce losses on that circuit. This is expensive, but not as expensive as the full reconstruction necessary to increase voltage. And sometimes there is no other alternative, as when a single-family residential area gradually converts to multifamily or commercial development.

Voltage affects losses by reducing the amperage needed to deliver any given number of watts to customers. By increasing voltage on a line – which usually means that new transformers must also be installed – a utility can reduce the amperage in the line. Higher-voltage lines also generally require taller poles, however, and the costs involved in setting new poles may be prohibitive. The use of underground cable for higher-voltage lines is several times more expensive than overhead construction and is generally limited to relatively short distances and relatively flat terrain.

## **Implemented of Smart LED street Lighting in the direction of the visions of MIV 2030 by implementing innovative methods using latest technologies:**

Smart LED Street lighting is street lighting using high efficiency LED lamps with wireless control and monitoring systems which can be controlled and monitored automatically through IoT (Internet of Things). Through smart street lighting, the control and monitoring of the entire street light system can be done automatically without manual intervention.

## **Benefits of Demand Response Programs on Line Losses**

Demand response (DR) programs reduce loads during the highest demand hours on a system. These are the hours when line losses are highest, because the amperage on conductors is highest.

Because line losses are exponential, reducing load a little bit at peak hours results in an exponential reduction in line losses.

## Annual Energy audit report of Cochin Port Authority (2021-22)

Distribution Line Losses decrease can done in this:

- improve low voltage conductor.
- select size of transformer appropriate with loads.
- install low voltage capacitor.

Replacement of conventional transformer with star rated transformers:

Saving calculation:

Table 22: Saving calculation of recommendation

Type & Capacity	Yr. of mfr.	Standard No Load Loss ( watts)	Star rated No Load loss ( Watts)	Difference in Watts
11 KV/433 V, 630 KVA	1992	894.6	655.2	239.4
11 KV/433 V, 315 KVA	1975	447.3	327.6	119.7
11 KV/433 V, 800 KVA	1981	1136	832	304
3.3 KV/433 V, 315 KVA	1982	447.3	327.6	119.7
3.3 KV/400 V, 250 KVA	1968	355	260	95
11 KV/433 V, 500 KVA	1979	894.6	655.2	239.4
3.3 KV/400 V, 750 KVA	1979	1065	780	285
3.3 KV/433 V, 500 KVA	2012	894.6	655.2	239.4
11 KV/433 V, 500 KVA	2010	894.6	655.2	239.4
3.3 KV/433V, 500 KVA	1987	894.6	655.2	239.4
3.3 KV/433V, 200 KVA	1994	295	230	65
3.3 KV/433V, 300 KVA	1985	435.6	310.3	125.3
3.3KV/415V - 250KVA		355	260	95
11 KV/433 V - 500 KVA	1978	894.6	655.2	239.4
11 KV/433 V - 630 KVA	1977	894.6	655.2	239.4
11 KV/ 3.3 KV - 1250 KVA	1988	1321	980	341
11 KV/3.3 KV - 1250 KVA	1988	1321	980	341
11 KV/3.3 KV - 1000 KVA	2008	1242	950	292
3.3 KV/433V-500 KVA	1978	894.6	655.2	239.4
3.3 KV/433V-750 KVA	1993	1065		1065
3.3 KV/433V-500 KVA		894.6		894.6
Total Watts can be saved				6057.5
Total Energy can be saved annually (kWh)				53063.7
Total Loss in 2021-22 kW				1313000
Loss after replacement of transformer				1259936.3
% of loss reduction				4.04
% T&C loss				3.577
% T&C loss after Transformer replacement				3.432

Since no test reports are available for No-load losses of transformers. So Standard values are considered for calculation.

Annual Energy audit report of Cochin Port Authority  
(2021-22)

CERTIFICATION

This Part shall indicate certification by Accredited Energy Auditor stating that: -

- I. The data collection has been carried out diligently and truthfully.
- II. All data monitoring devices are in good working condition and have been calibrated or certified by approved agencies authorized and no tampering of such device has occurred.
- III. All reasonable professional skill, care and diligence had been taken in preparing the Energy Audit Report as per the Bureau of energy efficiency regulations for manner and intervals for conduct of energy audit in electricity distribution companies ( Vide Bureau of energy efficiency notification dated 6th Oct 2021) and the contents thereof are a true representation of the facts.
- IV. Adequate training provided to personnel involved in daily operation after implementation of recommendation.



Signature:

Name of the Accredited Energy Auditor: Mr .T.N Agrawal  
Certified Detail: AEA-0089

Seal



# Annual Energy audit report of Cochin Port Authority (2021-22)

## 8. Annexure

### 8.1 Check list prepared by auditing firm

The check list prepared for Annual Energy Audit is presented in the following table:

Table 23: Check List for Energy Audit

S. No	Reference	Name	Available Monitoring System
<b>FY 2021-22 Data Verification</b>			
<b>Input Energy</b>			
1	A1 to A22	Input Energy (MU)	
<b>Division Losses</b>			
2	Column A toW	No of connectionmetered (Nos)	
		No of connectionUn-metered (Nos)	
		Connected Load Metered (MW)	
		Connected Load Un-metered (MW)	
		Input Energy (MU)	
		Metered energy(MU)	
		Unmetered energy/AssessmentEnergy (MU)	
		T&D Losses (MU)	
		Billed Amount	
		Collected Amount	
AT&C Loss			
<b>Details of Input Energy Sources</b>			
3	A	Generation atTransmission Periphery (Details)	
	B	Embedded Generation in DISCOM Area	
<b>Details of Feeder wise Losses</b>			

## Annual Energy audit report of Cochin Port Authority (2021-22)

Apart from this the audit team also reviewed the status of the DISCOM vis-à-vis the Clauses and Schedules of the Bureau of Energy Efficiency (Manner and Intervals for Conduct of Energy Audit in electricity distribution companies) Regulations, 2021.

Table 24: Clauses of BEE regulations

<b>Clauses of BEE Regulations</b>			
Clause No	Clause Details	Sub Clause Number	Subclause Details
3	Intervals of time for conduct of annual energy audit	a	Conducted an annual energy audit for every financial year and submitted the annual energy audit report to the Bureau and respective State Designated Agency and also made available on the website of the electricity distribution company within a period of four months from the expiry of the relevant financial year
4	Intervals of time for conduct of periodic energy accounting.	a	All feeder wise, circle wise and division wise periodic energy accounting is conducted by the energy manager of the electricity distribution company for each quarter of the financial year.
		b	Submitted the periodic energy accounting report to the Bureau and respective State Designated Agency and also made available on the website of electricity distribution company within forty- five days from the date of the periodic energy accounting.
		c	Electricity distribution company conducted its first periodic energy accounting, for the last quarter of the financial year immediately preceding the date of such commencement (i.e. 6th October 2021).
		d	Electricity distribution company conducted its subsequent periodic energy accounting for each quarter of the financial year for a period of two financial years from the date of such commencement, and submit the periodic energy accounting report within sixty days from the date of periodic energy accounting.
5		a	Identification and mapping of all of the electrical network assets
		b	Identification and mapping of high tension and low-

Annual Energy audit report of Cochin Port Authority  
(2021-22)

<b>Clauses of BEE Regulations</b>			
Clause No	Clause Details	Sub Clause Number	Subclause Details
	Pre-requisites for annual energy audit and periodic energy accounting		tensionconsumers
		C	Development and implementation of information technology enabled energy accounting and audit system, including associatedsoftware
		d	Electricity distribution company ensures the installation of functional meters for all consumers, transformers and feeders. Meter installation is done in a phased manner within a period ofthree financial years from the date of the commencement of these regulations in accordance with the trajectory set out in the First Schedule
			d.1. 100% Communicable Feeder Metering integrated with AMI,by 31st December 2022 along with replacement of existing non- communicable feeder meters.
			d.2. All <b>Distribution Transformers</b> (other than HVDS DT up to25kVA and other DTs below 25 kVA) shall be metered with communicable meters. Communicable DT Metering for the following areas/ consumers to be completed by December 2023and in balance areas by December 2025: d.2.1. All Electricity Divisions of 500 AMRUT cities, withAT&C Losses > 15% d.2.2. All Union Territories (for areas with technical difficulty, non-communicable meters may be installed) d.2.3. All Industrial and Commercial consumers d.2.4. All Government offices at Block level and above Other high loss areas i.e. rural areas with losses more than25% and urban areas with losses more than 15% d.3.5. Other high loss areas i.e. rural areas with losses more than25% and urban areas with losses more than 15%.
		E	d.4. Consumer Metering:98% by FY 2022-23 99% by FY 2023-24
		f	d.5. Targets for functional meters— Meter FY 22 23 FY 23-24 FY24-25 Feeder metering 98.5%



Annual Energy audit report of Cochin Port Authority  
(2021-22)

<b>Clauses of BEE Regulations</b>			
Clause No	Clause Details	Sub Clause Number	Subclause Details
			99.5% 99.5% DT metering 90% 95% 98% Consumer metering 93% 96% 98%
		g	Electricity distribution company has a centralized energy accounting and audit cell comprising of— (i) a nodal officer, an energy manager and an information technology manager, having professional experience of not less than five years; and (ii) a financial manager having professional experience of not less than five years
6	Reporting requirements for annual energy audit and periodic energy accounting	a	Electricity distribution company has a nodal officer, who is a full time employee of the electricity distribution company in the rank of the Chief Engineer or above, for the purpose of reporting of the annual energy audit and periodic energy accounting and communicate the same to the Bureau.
		b	Electricity distribution company ensures that the energy accounting data is generated from a metering system or till such time the metering system is not in place, by an agreed method of assumption as may be prescribed by the State Commission
		c	Metering of distribution transformers at High Voltage Distribution System up to 25KVA is done on cluster meter installed by the electricity distribution company
		d	The energy accounting and audit system and software is developed to create monthly, quarterly and yearly energy accounting reports.
		e	Electricity distribution company has provided the details of the information technology system in place as specified in clause (f) of regulation 5 that ensures minimal manual intervention in creating the energy accounting reports and any manual intervention of any nature, in respect of the period specified therein, shall be clearly indicated in the periodic energy accounting report

# Annual Energy audit report of Cochin Port Authority (2021-22)

## 8.2 Brief approach, scope & methodology for audit

The methodology adopted for conducting the Annual Energy Audit is as follows

- Verification of existing pattern of energy distribution across periphery of electricity distribution company
- Verification of accounted energy flow submitted by electricity distribution company at all applicable voltage levels of the distribution network
- Collection of data on energy received, and distributed, covered within the scope of energy audit
- Analyze the consistency of data monitoring compared to the collected data
- Recommendations to facilitate energy accounting and improve energy efficiency
- Analyze the data with respect to the purpose of energy accounting in reducing losses for the electricity distribution company
- Field studies and measurements on sample feeder.

# Annual Energy audit report of Cochin Port Authority (2021-22)

## 8.3 Infrastructure details

The Asset details includes the no of transformers, substations and feeders which are tabled above.

Table 25: Infrastructure details

Sr. No.	Particulars	Value in FY 2020-2021
1	No of Sub station ( 110 KV to 11 KV)	11
3	Length of 11 KV line (Ckt KM)	84
4	Length of Low-tension line ( Ckt KM)	252
5	Number of Distribution Transformers	46
6	Number of circles	1
7	Number of divisions	0
8	Number of Feeders	15
9	Number of RMU	73

Table 26: List of Transformers under T& Sections

LIST OF TRANSFORMERS UNDER T&R SECTION - AS ON YEAR 2021							
Sl. No.	Transformer Details				Location	Port sl.no.	Remarks
	Type & Capacity	Make	Maker's Sl.no.	Yr. of mfr.			
1	11 KV/433 V, 630 KVA	KEL	26643	1992	Mattancherry Halt S/s.	1	
2	11 KV/433 V, 315 KVA	Crompton parkison Ltd	29826V	1975	Mattancherry Halt Qtrs.	2	To be Replaced with New
3	11 KV/433 V, 500 KVA	KEL	58942	2008	SBI RMU (Coal Stacking Area)	46	
4	11 KV/433 V, 250 KVA	Unipower	2263	2011	A3 Area, IMU Campus	USS 01	
5	11 KV/433 V, 500 KVA	Megawin	947	2014	Subramaniyam Road	USS 02	
7	11 KV/433V, 100 KVA	Intrans		2012	Brought from outside BTP S/S		Standby at T &R
8	3.3 KV/433 V, 315 KVA	KEL	5937	1982	Mattancherry Wharf No.I S/s. Power	9	To be Removed after 11 KV upgradation under RDSS
9	3.3 KV/400 V, 250 KVA	Kirloskar		1968	Mattancherry Wharf No.I S/s. Lighting	10	To be Removed after 11 KV upgradation under RDSS

**Annual Energy audit report of Cochin Port Authority  
(2021-22)**

<b>LIST OF TRANSFORMERS UNDER T&amp;R SECTION - AS ON YEAR 2021</b>							
Sl. No.	Transformer Details				Location	Port sl.no.	Remarks
	Type & Capacity	Make	Maker's Sl.no.	Yr. of mfr.			
10	11 KV/433 V, 630 KVA	Intrans	T-2676	2019	New Leasing Area		IPDS Scheme. Commissioned on 27.07.2019
11	11 KV/433 V, 500 KVA	KEL	4821	1979	110 KV Substation compound	35	To be replaced with New under RDSS
12	11 KV/433 V, 630 KVA	Talwane	TPE 740	2009	RNAS		
13	11 KV/433 V, 630 KVA	Intrans	T-2677	2018	RNAS		IPDS Scheme. Commissioned on 01.09.2019
14	3.3 KV/400 V, 750 KVA	NEI	T-450285	1979	CASINO Substation	39	To be Removed after 11 KV upgradation under RDSS
15	3.3 KV/433 V, 500 KVA	Intrans	T-1653	2012	Hospital Substation	USS 03	
16	11 KV/433 V, 630 KVA	Intrans	T-2678	2019	Konkan - 2		IPDS Scheme. Commissioned on 23.08.2019
17	11 KV/433 V, 250 KVA	Resi Tech	TR-205	2018	Walkway RMU Premise		
18	11 KV/433 V, 315 KVA	Resi Tech	TR-205	2018	Tropicana RMU Premise		
20	11 KV/433 V, 500 KVA			2010	VALLARPADOM SUBSTATION		with lesse capacity of 160 KVA
21	11 KV/433 V, 250 KVA			2018	IOC SS		
23	11 KV/433 V, 160 KVA			2014	NEAR SEZ office Puthuvypin		

Table 27: List of transformers under North end

<b>LIST OF TRANSFORMERS UNDER NORTH END</b>				
Sl. No.	Transformer Details		Location	Remarks
	Type & Capacity			
1	3.3 KV/433V, 500 KVA		N.End	1987 Other than Admn. Building

Annual Energy audit report of Cochin Port Authority  
(2021-22)

<b>LIST OF TRANSFORMERS UNDER NORTH END</b>				
Sl. No.	Transformer Details	Location		Remarks
	Type & Capacity			
2	3.3 KV/433V, 200 KVA	N.End	1994	Admn building purpose only
3	11 KV/433 V, 500 KVA	N.End	2022	, KEL
4	11 KV/433 V, 800 KVA	BTP Substation	2001	
5	3.3 KV/433V, 300 KVA	IDP Substation	1985	
<b>LIST OF TRANSFORMERS UNDER ERNAKULAM WHARF</b>				
1	11KV/3.3KV - 630kVA	E/Wharf :Substation premises	2012	Sl.no. 1599, Intrans
2	3.3KV/415V - 250KVA	E/Wharf :Substation premises	Nil	Sl.no. 88026
3	11KV/433V - 500 KVA	E/Wharf :Substation premises	2002	Sl.no. 46534, KEL
4	11`KV/433V - 630 KVA	Old leasing Area	1996	Sl.no. 36884
5	11`KV/433V - 630 KVA	Old leasing Area	2004	Sl,no. 48824, KEL
6	11 KV/433 V - 500 KVA	SAGARIKA Cruise Terminal	1978	Sl.no. 5895, Indian Transformers Ltd
7	11 KV/433 V -1250 KVA	Q9 Substation	2009	Sl.no.739
8	11 KV/433 V - 630 KVA	Q5 Substation	1977	Sl.no.16969
9	11 KV/433 V - 800 KVA	Q10 Substation CFS	1986	Sl.no. 8333, KEL
10	11 KV/433 V - 500 KVA	CWC	2005	Sl.no. 52888
1	11`KV/433V - 630 KVA	UTL shore supply	2021	
2	11`KV/433V - 1250 KVA	Q2 shore supply	2021	
Power House/T&R Premises				
1	11 KV/ 3.3 KV - 1250 KVA	KEL	1988	Inside power transformer room adjacent to west side of NPH
2	11 KV/3.3 KV - 1250 KVA	KEL	1988	
3	11 KV/3.3 KV - 1000 KVA	KEL	2008	
4	3.3 KV/433V-500 KVA	KEL	1978	NPH Premises - station trans
5	3.3 KV/433V-750 KVA		1993	in between NPH and T&R building
6	3.3 KV/433V-500 KVA			West side of NPH building

# Annual Energy audit report of Cochin Port Authority (2021-22)

Table 28: List of RMU's

<b>I. 11 K.V RMU : W/Island Area</b>					
Sl.no.	Name of RMU	Type	Sl.no.	Name of RMU	Type
1	North End	Air	36	MNC	SF6
2	Customs	Air	37	FACT AM	Air
3	MMD	Air	38	UTL Berth	Air
4	IDP	Air	39	M/W	Air
5	Parrisons	Air	40	M/W Coast Guard	SF6
6	Samudrika	Air	41	HHA	SF6
7	Zuari	Air	42	ISRF	SF6
8	Penna	SF6	43	M/ H Qtrs	Air
9	Q5	Air	44	Simplex	SF6
10	E/ Wharf	Air	45	Konkan -1 MH SSn	Air
11	OLA	Air	46	110 KV Q9 -1	Air
12	Subramanian Rd	Air	47	Konkan -2	Air
13	Tea Board UTL	Air	48	NTRO A2 Konkan	SF6
14	Tea Board Q9 1	Air	49	Tropicana	Air
15	UTL Admin	Air	50	Walkway	SF6
16	SBI OB	Air	51	IMU	SF6
17	LA RMU 1	Air		<b>II. 11 K.V RMU : Vallarpadam Area</b>	
18	HML	Air	52	Outside 1 S Sn	Air
19	NPH Outside RMU	Air	53	Outside 2 S Sn	Air
20	CWC	Air	54	Mult 1 S Sn	SF6
21	S. Koder	Air	55	Mult 2 IOC	SF6
22	Evergreen	SF6	56	Mult 3 Cess Bldg.	SF6
23	Q8 Cruise	SF6	57	Mult 4 CMLRE	SF6
24	Q10 - 1	Air	58	MULT Turn	SF6
25	Q10 - 2	SF6	59	MULT Gate	SF6
26	Q10 Gate	SF6	61	IOC 1	SF6
27	Q10 NTRO	SF6	63	IOC 2	SF6
28	Tetly	Air	65	IOC 3	SF6
29	Kokkanadan	Air	67	IOC 4	SF6
30	Near Rail Q9-3	Air		<b>III. 3.3 KV RMU</b>	
31	NLA -1	Air	68	North End	Air
32	NLA -2	Air	69	Casino	Air
33	Temple Q9 -2	Air	70	E/ Wharf	Air
34	NTRO RNAS	SF6	71	M/ Wharf	Air
35	NTRO KV	SF6	72	NPH	Air
			73	Hospital	Air

# Annual Energy audit report of Cochin Port Authority (2021-22)

## 8.4 Power purchase details

The licensee revised the power purchase for the control period subsequently. As per revised form D3.1 (Power Purchase Expenses) the licensee has shown the details of the proposed power purchase cost for the control period, which includes the cost for power purchase from KSEB Ltd and own Solar Generation.

The power purchase cost claimed by the licensee for the year 2021-22 amounts to Rs.2533.3 lakh for a purchase of 363.61 lakh units. This amount included power purchase from KSEB Ltd, Own generation (Solar) and Open access power. Compared to 2019-20 (Rs.6.96/per unit) average power purchase cost has increased in the year 2021-22 (Rs.6.97/per unit).

Table 29: Power purchase details

Particulars	2021-22		
	W/Island	Vallarpadam	Total
Energy purchase (In lakh units)	254.945	108.662	363.61
Demand Charges (Rs. /KVA)	340	340	340
Total Demand charges (Rs in lakh) (A)	222.37	92.9152	315.29
Energy Charges (Rs. /KWh)	6.1	6.1	6.1
Total energy Charges (Rs.in lakhs) (B)	1555.16	662.835	2218
Cost of power purchase (A) +(B) (Rs.in lakh)	1777.53	755.75	2533.3
Average Power Purchase Cost (Rs. / per unit)			6.97



# Annual Energy audit report of Cochin Port Authority (2021-22)

## 8.5 Single Line diagram

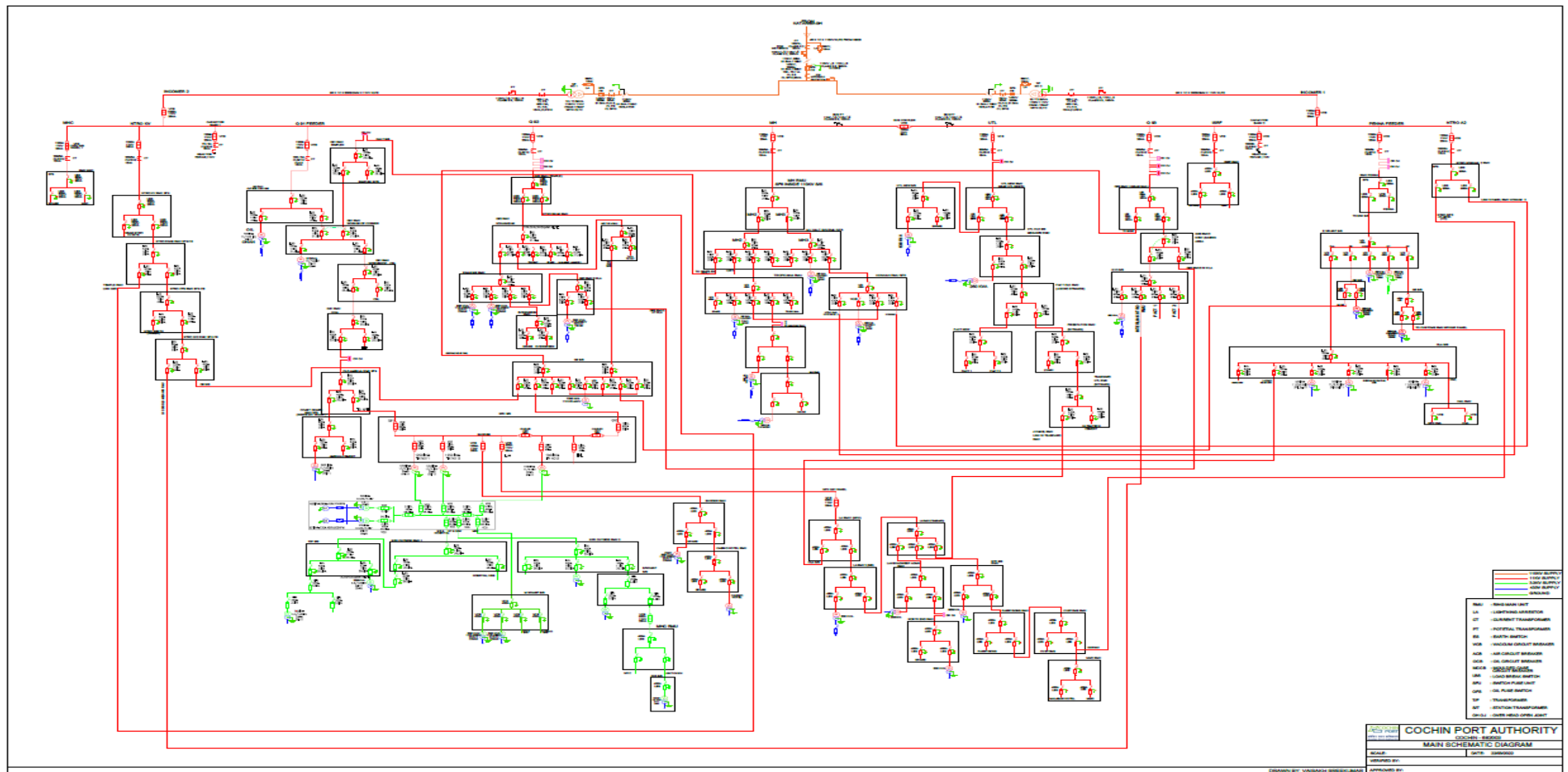

Figure 1:SLD of Willington Island

# Annual Energy audit report of Cochin Port Authority (2021-22)

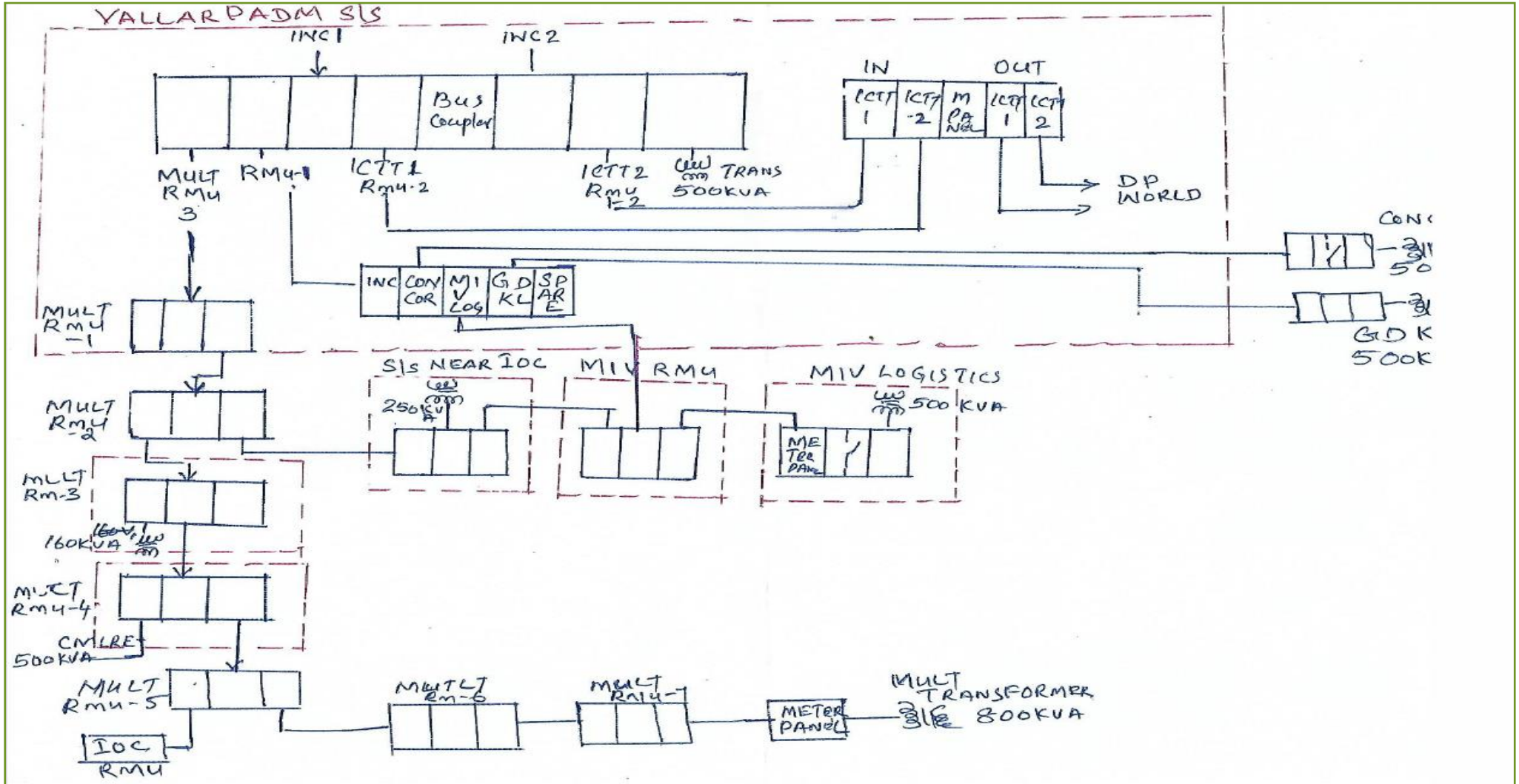

Figure 2: SLD of Vallarpadam



# Annual Energy audit report of Cochin Port Authority (2021-22)

## 8.6 Category of service details (with consumer and voltage- wise)

CoPA is supplying power to 1223 number of consumers as on 31st March 2022. The details of category wise consumers are presented in the following table:

Table 30: Energy cost realized on category wise

SL. No.	Particulars	Number of consumers	Units sold	Demand/ fixed charges	Energy Charges	Electricity Duty	Meter Hire Charge	Surcharge	Fuel Surcharge	Penal Interest	TOTAL
1	HT I GOVT	6	1359137	5193181.9	7548590.33	0	0	33974.68	0	0	12775746.91
4	HT I INDUSTRY	1	483572	1028521	2885862.82	48357.2	0	12130.7	0	0	3974871.72
2	HT II (B) C GOVT	1	342558	811800	2191148.63	0	0	8541.11	0	0	3011489.74
3	HT IV COMMERCIAL	23	20470407	46644682.2	150246523.4	15026756	0	512034.49	0	125251	212555246.7
5	HT IV B HOTEL	4	5027530	5819505	38859775.38	2451483.7	0	126478	0	35634	47292876.07
6	LT I DOMESTIC	457	726262	335738	2822374.7	333722.29	34410	0	0	0	3526244.99
7	LT II COLONY	2	301080	235200	2559180	255918	252	0	0	0	3050550
8	LT IV A (Industry) (RC3)	2	13605	112102	77252.25	7725.27	720	0	0	203	198002.52
9	LT VI A (RC4C)	14	268202	139165	1562214.9	156221.49	2544	0	0	1045	1861190.39
10	LT VI B	26	127236	146335.13	851126.71	81498.13	3696	0	0	316	1082971.97
11	LT VI B G	21	158469	268560	1089651	0	2988	0	0	433	1361632
12	LT VI C	7	243948	456840	2073467	207346.7	1557	0	0	19195	2758405.7
13	LT VI C G	12	64688	220320	525284	0	1512	0	0	0	747116
14	LT VI F	4	200288	119280	1802592	180259.2	1080	0	0	2232	2105443.2
15	LT VII A SINGLE PHASE	336	326404	565061	2415721.7	238420.77	23532	0	0	12309	3255044.47

Annual Energy audit report of Cochin Port Authority  
(2021-22)

SL. No.	Particulars	Number of consumers	Units sold	Demand/ fixed charges	Energy Charges	Electricity Duty	Meter Hire Charge	Surcharge	Fuel Surcharge	Penal Interest	TOTAL
16	LT VII A THREE PHASE	195	2763160	8589757	32927612.2	2503777.6	42261	0	0	102817	44166224.78
17	LT VII C	1	78	1143	468	46.8	72	0	0	11	1740.8
18	LT VIII B Street lights	3	9096	1800	39112.8	0	216	0	0	0	41128.8
19	Self consumption	107	2189078	1774940	11506464.85	357823.86	15228	0	0	0	13654456.71
20	STREET LIGHT-SELF	1	331021	600	1413401.4	0	180	0	0	0	1414181.4
	<b>TOTAL</b>	<b>1,223</b>	<b>35405819</b>								<b>358954169</b>

# Annual Energy audit report of Cochin Port Authority (2021-22)

## 8.7 list of documents verified with each parameter

The following are the documents verified during Annual Energy Audit:

Table 31: List of Documents verified

SrNo	Name	Supporting Document
<b>FY 2021-22 Data Verification</b>		
<b>Input Energy</b>		
<b>1</b>	Input Energy (MU) Sale of electricity ( MU)	The electricity bill from purchase, SAP is source of data for 2021-22. The Input energy purchased and net input energy (received at DISCOMperiphery or at distribution point, after adjustment)  Record of Metering & sales and purchase Section of CoPA.
<b>Division Losses</b>		
<b>2</b>	No of connection metered (Nos)	From the SAP yearly sales report (2021-22) Actual
	No of connection Un-metered (Nos)	
	Connected Load Metered (MW)	
	Connected Load Un-metered (MW)	
	Input Energy (MU)	
	Metered energy (MU)	
	Unmetered energy/Assessment Energy(MU)	
	T&D Losses (MU)	Calculated based on data from SAP sales and purchase department
	Billed Amount	Data is taken from the SAP yearly sales report ( 2021-22)
	Collected Amount	Data is taken from the SAP report ( 2021-22)
	AT&C Loss	Both the input and sales data is taken from electricity bill and SAP sales report (2021-22) . The difference is taken as loss.

Annual Energy audit report of Cochin Port Authority  
(2021-22)

SrNo	Name	Supporting Document
		Random checking of the data presented in the Proforma has been verified from the data maintained at the sub-division level during the field visit.
Details of Input Energy Sources		
3	Generation at Transmission Periphery (Details)	
	Embedded Generation in DISCOM Area	250 kWp solar plant is installed in the CoPA and generation is also considered for input energy through metered data.
Details of Feeder wise Losses		
4	Feeder wise Energy Accounting	There are totally 15 nos feeders in 202-21, only 11 nos of feeders are installed with AMI meter and for feeder wise accounting RMU also need to be installed with AMI meters which are planned in their upcoming RDSS scheme.